

SIEMENS

Ingenuity for life

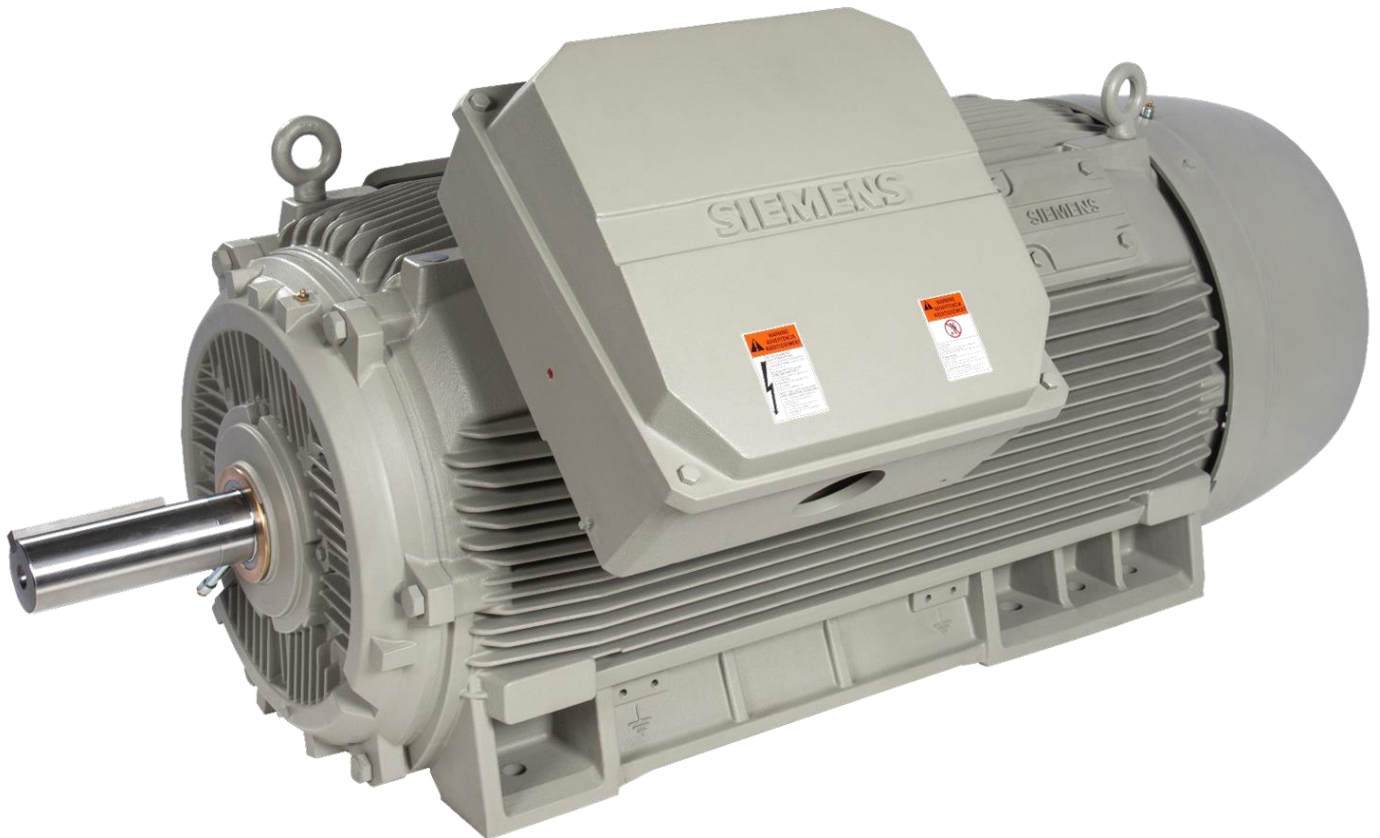

Catalog D81.2 | Edition 2019

SIMOTICS NEMA Motors

Low Voltage AC Motors
(449 Fr Medium Voltage)

GP, SD, XP, DP
Selection and Pricing Guide

[siemens.com/nema-motors](https://www.siemens.com/nema-motors)

Licensed Motors Have NEMA Premium® on their Nameplate



Buy with Confidence

Buying a motor can be a difficult process. Is it the right size for the application? Is it the right design? Is it going to last? Is it going to perform to its specifications? Will it meet efficiency claims? The last question is easy to answer if NEMA Premium® is on the label.

NEMA Premium® Licensees Meet a Higher Standard

All motor manufacturers are required to submit efficiency test data to the US Department of Energy to receive their Certificate of Compliance. Data must be compiled at any qualified testing facility, including the manufacturers' own test laboratory. It takes extra to wear the NEMA Premium® label. A NEMA Premium® Licensee has agreed to go beyond minimum US DOE requirements.

NEMA Premium® Licensees Must Prove Efficiency Claims

What's on the nameplate is not what you always get when it comes to efficiency. Most manufacturers will attempt to ship what is on the nameplate, but do not always deliver. If you want assurance that a motor meets its efficiency claims, look for a NEMA Premium® certified motor.

NEMA Premium® Licensees Must Submit to Third Party Testing

NEMA Premium® Licensees are required to ship motors from distributor's inventory to a third party qualified laboratory for efficiency verification testing on a regular schedule. The specified motor is randomly selected. NEMA Premium® Licensees deliver what they claim, and you can buy with assurance.

Table of Contents

1 – Introduction

- [1-1](#) Wide Selection of Motors
- [1-2](#) Electric Motor Energy Efficiency
- [1-3](#) Warranty and Support
- [1-5](#) Cancellation Charges and Change Notices
- [1-6](#) Website and Tools

2 – Special Features

- [2-1](#) Option Codes
- [2-9](#) MLFB Structure
- [2-10](#) Voltage and Connection
- [2-12](#) Mounting
- [2-14](#) Winding Protection
- [2-17](#) Terminal Boxes and Leads
- [2-21](#) Bearings and Lubrication
- [2-26](#) Shaft and Seals
- [2-29](#) Frame
- [2-32](#) Rating Plates and Tagging
- [2-35](#) Ambient and Altitude
- [2-36](#) Mechanical Design and Accessories
- [2-40](#) Paint and Packaging
- [2-42](#) Documentation
- [2-44](#) Tests
- [2-45](#) VSD Operation

3 – Motor Selection and Pricing

- [3-1](#) SIMOTICS General Purpose Motors
GP100A
- [3-3](#) Aluminum Rotor
- [3-4](#) Copper Rotor
- [3-5](#) Aluminum Rotor - 575V
GP100
- [3-6](#) Aluminum Rotor
- [3-9](#) Copper Rotor
- [3-10](#) Aluminum Rotor - 575V
- [3-13](#) SIMOTICS Severe Duty Motors
SD100
- [3-15](#) Aluminum Rotor
- [3-19](#) Copper Rotor
- [3-20](#) Aluminum Rotor - 575V
SD100 IEEE841
- [3-24](#) Aluminum Rotor
- [3-28](#) Copper Rotor
- [3-29](#) Aluminum Rotor - 575V
SD661
- [3-33](#) Aluminum Rotor
- [3-34](#) SD200
- [3-35](#) SIMOTICS Explosion Proof Motors
- [3-37](#) XP100
- [3-40](#) XP100 575V
- [3-43](#) XP100 ID1
- [3-45](#) XP100 ID1 575V
- [3-46](#) XP JP Frame Motors
- [3-47](#) SIMOTICS Definite Purpose Motors

3 – Motor Selection and Pricing (continued)

- Vertical
- [3-49](#) LP100
- [3-51](#) HP100
- [3-53](#) SD10 MS
- [3-55](#) DP200

4 – Options Selection and Pricing

- [4-1](#) Modified Stock Options
- [4-7](#) Custom Build Options

5 – Typical Performance Details

SIMOTICS GP and SD Motors

- GP100A/GP100
- [5-1](#) Aluminum Rotor
- [5-3](#) Copper Rotor
SD100/SD100 IEEE841/SD661
- [5-4](#) Aluminum Rotor
- [5-7](#) Copper Rotor
- [5-8](#) SD200

SIMOTICS Explosion Proof Motors

- [5-9](#) XP100/XP100 IDI

SIMOTICS Definite Purpose Motors

- [5-11](#) LP100
- [5-13](#) HP100
- [5-15](#) SD200/DP200
- [5-16](#) SD10 MS

6 – General Dimensions

SIMOTICS General Purpose Motors

- [6-2](#) GP100

SIMOTICS Severe Duty Motors

- [6-6](#) SD100
- [6-10](#) SD100 IEEE841/SD661
- [6-14](#) SD200

SIMOTICS Explosion Proof Motors

- [6-16](#) XP100/XP100 IDI

SIMOTICS Definite Purpose Motors

- [6-20](#) SD10 MS
- [6-24](#) HP100/LP100

SIMOTICS Conduit Boxes

- [6-26](#) General Purpose GP100A/GP100
- [6-28](#) Severe Duty SD100/SD100 IEEE841/SD661
- [6-30](#) Explosion Proof XP100/XP100 IDI
- [6-31](#) SD200

7 – MV 449 Frame

SIMOTICS Advantage Series Motors

- [7-1](#) Introduction
- [7-3](#) Motor Selection & Pricing
- [7-4](#) Typical Performance Details
- [7-7](#) Standard Features
- [7-8](#) Modifications and Accessories
- [7-14](#) General Dimensions

8 – Short Codes Index

Introduction

Wide Selection of Motors

Wide selection

Providing value also means having the right motor for the job. At Siemens, we strive to offer a wide variety of motor types, in all frame sizes and power ratings with a comprehensive set of options and quick modifications.

Our LV NEMA motor portfolio consists of motors with power ratings of 1HP up to 900HP with a variety of voltages up to 600V, stocked to meet the needs of the North American market.

Need a motor for a special project...Siemens has that covered as well with a wide selection of modification and custom options available and a highly skilled quotation team to help ensure that the best selection for the job is offered.

Our highly qualified research and development group is working to add to this list as part of our commitment to become your single source for motors

The world's most energy efficient line of motors

Lower your energy costs today with the world's most energy efficient line of motors. New regulatory standards and rising energy costs create increasing pressure to maximize energy efficiency and reduce your carbon footprint.

To meet your cost of ownership and motor management needs, Siemens offers several levels of energy efficiency in many of its motors:

- NEMA Premium® (MG1 Table 12-12)
- NEMA Premium® Plus

Total customer support

Siemens is known as a Global leader in technology while also providing outstanding collaboration with partners and ensuring the success of our customers. A dedicated sales force with in-depth product knowledge and training is only a phone call away and available to provide a complete solution from a breadth of available products. Application and project support by dedicated teams have the customer's best interest in mind while reviewing technical content and offering competitive quotations. The Order Management team focusses on and takes great pride in putting our customers first. Fielding customer questions, providing order status updates and expediting shipments are just a few examples of this team's expertise and support.



Availability

Siemens has hundreds of distributor stocking locations throughout North America with a wide selection of NEMA and IEC frame sizes and ratings. Motors are available same day from a local source you can trust.

Need something special? Our modification centers have complete motor modification capabilities to help you get the exact motor you need, when you need it.

Iron-clad quality

The quality of our motors begins with the design experience we have gained through more than 100 years of manufacturing and installing motors. We build on this experience every day with new designs that incorporate the latest materials and techniques to provide even higher levels of performance, operating efficiency and reliability.

These advanced motor designs are manufactured in a state-of-the-art, ISO 9001 certified facility. Here, our manufacturing technicians subject each motor to more than 100 separate quality inspections before it leaves our plant ensuring it meets the high standards our customers expect

Introduction

Electric Motor Energy Efficiency

U.S. Dept. of Energy Integral Horsepower Motor Rule Effective June 1, 2016

The United States Department of Energy passed a final rule in 2014 that covers 1-500 HP (0.75 – 370 KW) 3-phase electric motors. The new law will supersede the Energy Independence & Security Act (EISA) of 2007 and become effective June 1, 2016. For reference and complete wording of the law, refer to:

<https://www.regulations.gov/document?D=EERE-2010-BT-STD-0027-0117>

The new legislation broadens the number of motor types covered and closes most of the loopholes that permitted exceptions in both EPA Act 1992 and EISA 2007 legislation. In essence, most 3-phase industrial motors manufactured will be required to meet the efficiencies listed in NEMA MG-1, table 12-12 (reference NEMA Premium® efficiency).

Additional motor types covered include, but are not limited to:

- 201-500 HP (previously 1- 200 HP)
- Footless (C-face & D-flange)
- Vertical (HP & LP)
- 8-pole (900 RPM)
- Brake motors (integral and add-on)
- Motors with customer special shafts, flanges, and mountings
- IEC 100 frame

Motors that are not covered by mandated efficiency regulations are:

- Multi-speed
- Inverter duty only

The majority of Siemens low voltage motors listed in this price guide currently meets, or exceeds, the June 1, 2016 mandatory regulations. Industry-leading, die cast copper rotor motors, exceed all efficiency requirements.

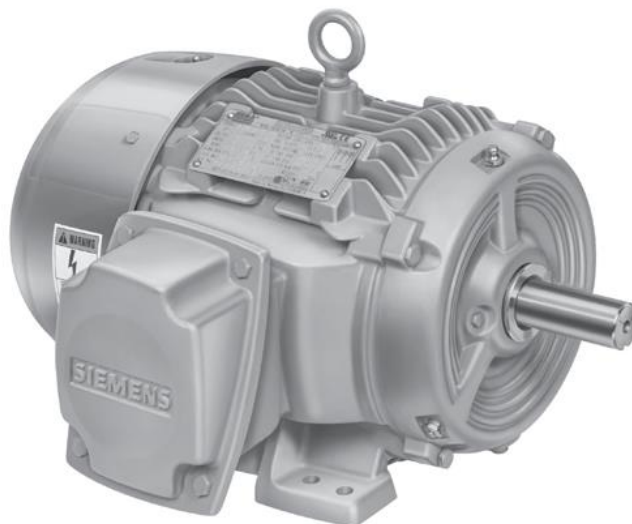

Introduction

Warranty and support

SIMOTICS NEMA Motors

Warranty procedure

Standard terms and conditions of sale

Warranty – Company warrants that on the date of shipment to purchaser the goods will be of the kind and quality described herein, merchantable, and free of defects in workmanship and material.

If within one year from date of operation, but not more than eighteen months from date of shipment by Company, of any item of the goods, purchaser discovers that such item was not as warranted above and promptly notifies company in written thereof, Company shall remedy such defect by, at Company's option, adjustment, repair, or replacement of the item and any affected part of the goods.

Purchaser shall assume all responsibility and expense for removal, reinstallation and freight in connection with the foregoing remedy. The same obligations and conditions shall extend to replacement items furnished by company here under. Company shall have the right of disposal of items replaced by it. Purchaser shall grant Company to determine any defect in the goods. In the event that adjustment, repair, or replacement does not remedy the defect, the Company and Purchaser shall negotiate in good faith an equitable adjustment in the contract price.

Service calls and overtime are not covered under Siemens warranty policy.

The Company's responsibility does not extend to any item of the goods which has not been manufactured and sold by Company. Such item shall be covered only by express warranty, if any, of the manufacture thereof. The Company and its suppliers shall also have no responsibility if the goods have been improperly stored, handled, or installed or if the goods have not been operated or maintained according to their ratings or according to instructions in Company or supplier furnished manuals, or if unauthorized repairs or modifications have been made to the goods.

THIS WARRANTY IS EXPRESSLY IN LIEU OF ALL OTHER WARRANTIES (EXCEPT TITLE), INCLUDING BUT NOT LIMITED TO IMPLIED WARRANTIES OF MERCHANTABILITY AND FITNESS, AND CONSTITUTES THE ONLY WARRANTY OF COMPANY WITH RESPECT TO THE GOODS.

The foregoing states Purchasers exclusive remedy against Company and its suppliers for any defect in the goods or for failure of the goods to be as warranted, whether Purchaser's remedy is based on contract, warranty, failure of such remedy to achieve its essential purpose, tort (including negligence), indemnity or any other legal theory, and whether arising out of warranties, representations, instructions, or defects from *any cause*.

SIMOTICS Warranty type		
A	GP100, GP100A	12 months in service or 18 months after shipment, whichever comes first
	SD10MS, SD100, XP100, XP 100 ID1, HP100, LP100, SD200	3 Years, after shipment
	SD100 IEEE841, SD661	5 Years, after shipment
B	Remedy	Siemens option to repair or replace
C	Purchaser's Responsibility	Transportation damage claims, Order management, Removal and freight
D	Exclusions	Improper storage, In and out costs, Disassembly and installation, transportation damages
E	Shipment Normal	FOB our dock, Freight allowed



Introduction

Warranty and support

Reference notes

1. After the inspection, contact Little Rock office for authorization of repair or replacement.
Unapproved repairs will be denied.
2. Removal, installation, freight, and service calls are NOT covered by warranty.
3. A standard EASA Warranty report must be filled out and, a Siemens job/purchase order # issued. The Warranty report and nameplate (if motor scrapped in the field) plus the invoice must be sent to the Little Rock Plant.
4. Replacement Parts – will be furnished at no charge from the factory, i.e., bearings fans, etc.
5. Replacement Motors – will be furnished at no charge from the factory. Should it be necessary for reasons of expediency for the service shop to replace a motor from their stock, a replacement motor will be furnished at no charge from the factory, shipped freight allowed.
6. Defective parts, i.e., bearings, are subject to return upon request to the factory for inspection and approval for reimbursement.

IMPORTANT NOTICE

MAIL or EMAIL A PROPER WARRANTY REPAIR REPORT, AND SUPPORTING EVIDENCE OF FAILURE TO THE WARRANTY ADMINISTRATOR, IF SIEMENS IS TO BE BILLED FOR OVERTIME, AUTHORIZATION MUST BE OBTAINED FROM WARRANTY ADMINISTRATOR BEFORE OVERTIME WORK IS PERFORMED. MATERIAL AND SERVICES ARE PURCHASED FOR RESALE AND ARE EXEMPT FROM STATE AND LOCAL SALES AND USE TAX.

Date coding

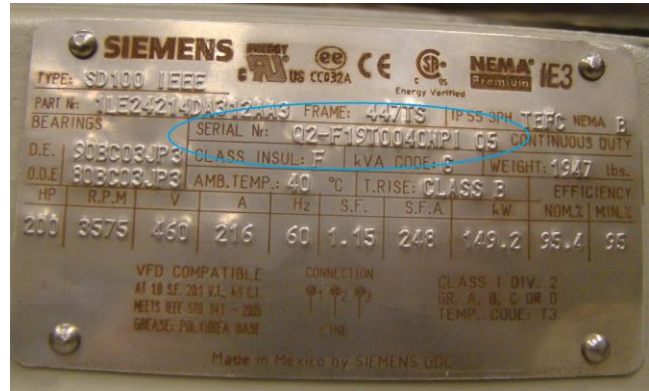

Siemens SIMOTICS motors date coded by the model number/date code/serial number on the nameplate.

Siemens date codes for NEMA frame size, low voltage motors built in USA and Mexico is as follows: The first digit is alphabetic and represents the month. The second and third digits are numeric and are the last two digits of the year.

A = January	G = July
B = February	H = August
C = March	J = September
D = April	K = October
E = May	L = November
F = June	M = December



Introduction

Cancellation charges and change notices

Cancellation charges

Note: A minimum charge of \$100 will be assessed for any order cancellation for modified or custom motors.

Stock motors and Spares

- No charges will be incurred if an order is cancelled prior to shipment.
- A stock motor is returnable (freight paid by purchaser) immediately after shipment if returned in "new" condition (original, undamaged packaging) for a minimum restocking charge of 20% of the motor net price.

Non-stock motors

- For non-stock motors, the following table will apply to determine cancellation charges after the order is received and entered at the factory. Completion week will be determined by a Siemens Customer Service Representative.
- A charge of 15% of the total net motor price will be assessed if an order is cancelled after it has been released for engineering and drafting whether or not the drawings have been completed and/or submitted for approval.

Motor Cancellation charges				
Week	Contract A1	Contract A2	Contract B	
1	0%	0%	0%	
2	50%	25%		
3	95%	50%	25%	
4	100%	90%	50%	
5		100%	75%	
6			90%	
7			100%	100%
8				
9				
10				
>10				

Change notice

All change notices applied to in-process orders logged into the Siemens customer service department and requiring a product change will be subject to a \$100 net charge plus the applicable modification adder. Delivery dates will be adjusted according to the type of change/modification requested. This policy does not pertain to commercial changes such as "ship to" or "bill to" addresses.



Introduction

Selection and configuration tools

In our **website** you will find all sorts of useful information, pre-sales information, technical information, contacts and local partners as well as on-line support.

www.us.siemens.com/nema-motors

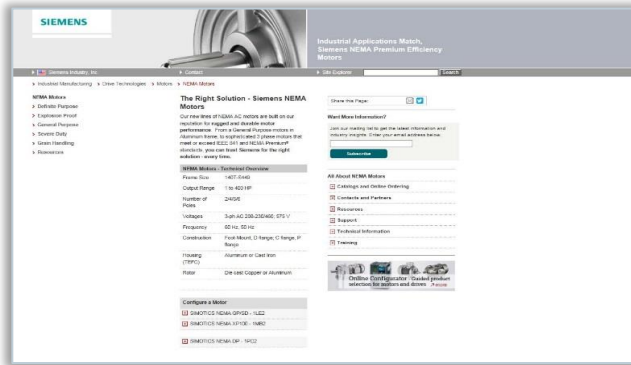

The **DT configurator** has been developed to facilitate the selection of motors and its wide range of special features. It is integrated as an offline "Selection Tool" in the interactive catalog CA01 and is also available online. The DT Configurator not only renders the correct ordering part number for you, but also provide all relevant documentation to the selection, operating instructions, data sheets, curves and dimensional drawings.

www.siemens.com/dtconfigurator

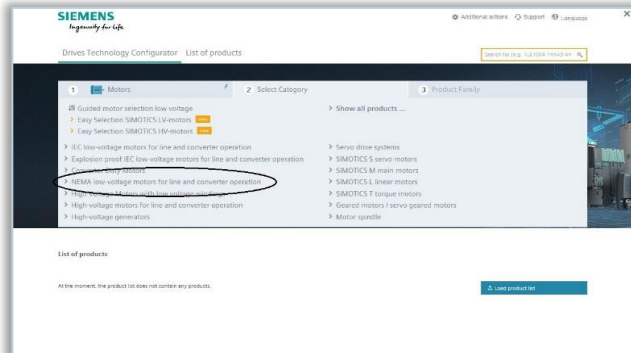
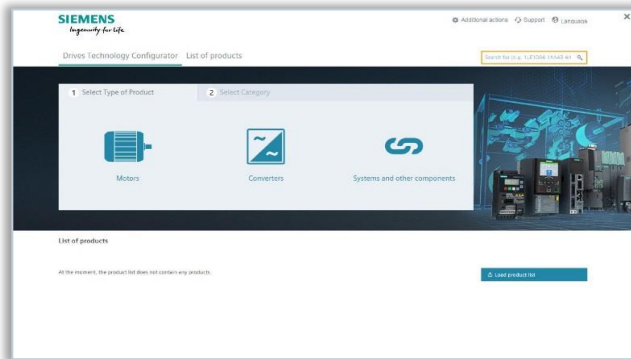

Size configuration tool provides an easy-to-use means for configuring drives and controls while at the same time supports all engineering steps in one workflow:

- Configuring the power supply
- Motor and gearbox design, including calculations of mechanical transmission elements
- Configuring the drive components
- Selecting the required accessories
- Selecting the line-side and motor-side power options, e.g., cables, filters, and reactors

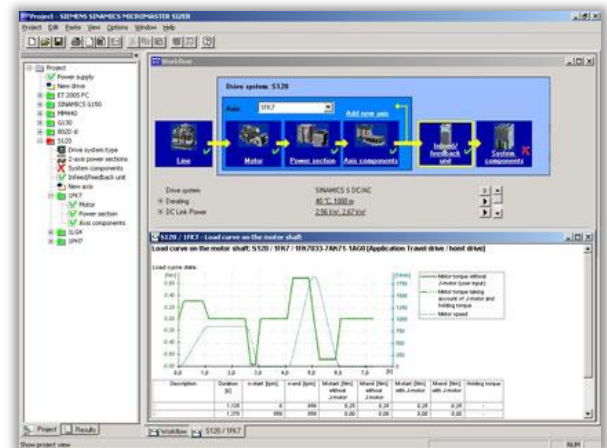

Introduction

“The Most Powerful Motor App Ever Designed for a Mobile Device.” **Motor Toolkit** delivers comprehensive industry resources and connects industry professional motor support anywhere, anytime. Motor Toolkit provides a wealth of information, whether you’re looking to upgrade your equipment with a new motor, order spares or troubleshoot your application in the field. The camera features connect you to our Siemens product or service teams.



The energy-saving program **SinaSave** is suitable for application with motors for on-line fed operation (fixed speed) and inverter-fed (variable speed). With on-line operation, you can calculate the cost savings as well as the amortization time for the additional cost of the Siemens energy-saving motors with three different comparisons and overall plant analysis.

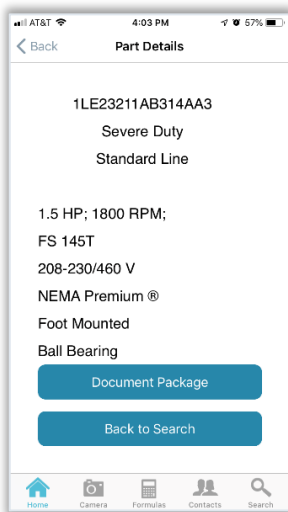
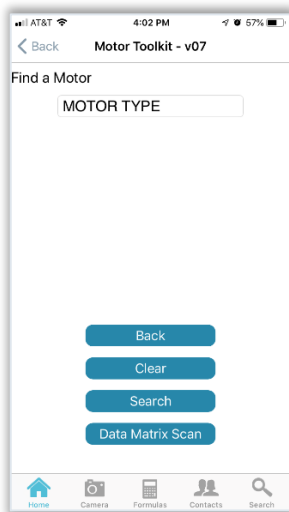



Special Features – Option Codes

	1LE2	1MB2	1PC2	1LE6	1PC6 HPS	Codes	Description	For further information, see page(s)	For price information, see page(s)
Voltage and Connection									
MLFB DIGITS 12 & 13	✓	✓	✓	--	--	11	230V	2-10	4-1, 4-7
	✓	✓	✓	✓	✓	12	460V	2-10	4-1, 4-7
	✓	✓	✓	✓	✓	13	575V	2-10	4-7
	✓	✓	✓	--	--	14	230/460 (suitable for 208V)	2-10	4-7
	✓	✓	✓	--	--	16	230/460	2-10	4-1, 4-7
	✓	✓	✓	✓	✓	22	PWS 460V 60Hz	2-10	4-1, 4-7
	✓	✓	✓	✓	✓	23	PWS 575V 60HZ	2-10	4-7
	✓	✓	✓	✓	✓	32	Y/D 460V 60Hz	2-10	4-1, 4-7
	✓	✓	✓	✓	✓	33	Y/D 575V 60HZ	2-10	4-7
	✓	✓	✓	✓	✓	90	200-600V (M1Y 200-460,M2Y 461-600)	2-10	4-7
SHORT CODES	✓	✓	✓	✓	✓	M1Y	Special Voltage 200-460V	2-10	4-7
	✓	✓	✓	✓	✓	M2Y	Special Voltage 461-600V	2-10	4-7
Mounting									
MLFB DIGIT 14	✓	✓	--	--	--	A	Foot Mount	2-12, 2-13	4-7
	✓	✓	--	--	--	E	C - Face with Feet	2-12, 2-13	4-1, 4-7
	✓	✓	--	--	--	F	D - Flange with Feet	2-12, 2-13	4-1, 4-7
	✓	✓	--	--	--	G	C - Face without Feet	2-12, 2-13	4-1, 4-7
	✓	✓	--	--	--	H	D - Flange without Feet	2-12, 2-13	4-1, 4-7
	✓	✓	--	--	--	L	C - Face without Feet with Drip Cover and Lifting Hooks	2-12, 2-13	4-1, 4-7
	✓	✓	--	--	--	M	D - Flange without Feet with Drip Cover and Lifting Hooks	2-12, 2-13	4-1, 4-7
	✓	✓	--	--	--	N	C - Face w Feet with Drip Cover	2-12, 2-13	4-1, 4-7
	✓	✓	--	--	--	P	D - Flange with Feet with Drip Cover	2-12, 2-13	4-1, 4-7
	--	--	✓	--	--	T	P-Base without Feet with Drip Cover and Lifting Hooks	2-12, 2-13	4-7
	--	✓	--	--	--	V	CH - Flange with feet with Drip Cover and Lifting Hooks	2-12, 2-13	4-7
	--	✓	--	--	--	W	CH - Flange with Feet	2-12, 2-13	4-7
	--	✓	--	--	--	X	CH - Flange without Feet	2-12, 2-13	4-8
	--	✓	--	--	--	Y	CH - Flange without Feet with Drip Cover and Lifting Hooks	2-12, 2-13	4-8
	--	--	--	✓	✓	A	Foot Mounted (Horizontal IMB3)	2-12, 2-13	4-8
	--	--	--	✓	✓	C	Foot Mounted Vertical Shaft-down without Canopy (IMV5)	2-12, 2-13	4-1, 4-8
	--	--	--	✓	✓	D	Foot Mounted Vertical Shaft-Up (IMV6)	2-12, 2-13	4-1, 4-8
	--	--	--	✓	✓	J	Foot Mounted D-Flange Horizontal (IMB35 – F1/F2/F3)	2-12, 2-13	4-8
--	--	--	✓	✓	R	Foot Mounted D-Flange Vertical Shaft-Down – W6/W7/W12	2-12, 2-13	4-8	
--	--	--	✓	✓	S	Foot Mounted D-Flange Vertical Shaft-Up – W5/W8/W11	2-12, 2-13	4-8	

Special Features – Option Codes (continued)

	1LE2	1MB2	1PC2	1LE6	1PC6 HPS	Codes	Description	For further information, see page(s)	For price information, see page(s)
Winding Protection									
MLFB DIGIT 15	✓	✓	✓	✓	✓	A	No Protection	2-14	4-8
	✓	✓	✓	✓	✓	B	PTC 3 Embedded, 1 Per Phase	2-14, 2-16	4-8
	✓	✓	✓	✓	✓	C	PTC 6 Embedded, 2 Per Phase	2-14, 2-16	4-8
	✓	✓	✓	✓	✓	G	Thermostats Normally Closed, Temp Code T3C, 1 Per Phase	2-14, 2-16	4-2, 4-8
	--	--	--	✓	✓	H	Thermostats Normally Closed, Temp Code T3 – 200°C, 1 Per Phase	2-14	4-2, 4-8
	✓	✓	✓	✓	✓	J	Thermocouples Coil Head	2-14	4-8
	✓	✓	✓	✓	✓	K	Stator RTD's 100 – Ohm Platinum w Aux Box-terminal Strip 2/Phase	2-14, 2-16	4-8
	✓	✓	✓	✓	✓	L	Winding Protection – G + K	2-14	4-2, 4-8
	✓	✓	✓	✓	✓	M	Winding Protection – H + K	2-14	4-2, 4-8
	✓	✓	✓	✓	✓	P	PT1000, 2 Embedded Temperature Sensors	2-14, 2-16	4-8
Short Codes	✓	--	✓	--	--	A40	Space Heaters 115V Single Phase	2-14, 2-15	4-2, 4-9
	✓	--	✓	--	--	A41	Space Heaters 230V Single Phase	2-14, 2-15	4-2, 4-9
	✓	--	✓	--	--	A42	Space Heaters 115V Single Phase, Division 2	2-14, 2-15	4-2, 4-9
	--	✓	--	--	--	A43	Space Heaters 115V Single Phase, Explosion Proof	2-14, 2-15	4-2, 4-9
	✓	--	✓	--	--	A44	Space Heaters 230V Single Phase, Division 2	2-14, 2-15	4-2, 4-9
	--	✓	--	--	--	A45	Space Heaters 230V Single Phase, Explosion Proof	2-14, 2-15	4-2, 4-9
	✓	✓	✓	✓	✓	A46	Space Heaters 115V Single Phase, Max Temp 160°C	2-14, 2-15	4-2, 4-9
	✓	✓	✓	✓	✓	A47	Space Heaters 230V Single Phase, Max Temp 160°C	2-14, 2-15	4-2, 4-9
	✓	✓	✓	--	--	A90	Control Module	2-14	4-9
	✓	✓	✓	■	■	C00	Insulation Class H	2-14, 2-39, 2-45	4-9
	✓	✓	✓	✓	✓	C01	Insulation Vacuum Pressure Impregnation (VPI)	2-14	4-9
	✓	✓	✓	✓	✓	C03	Spike Resistant Wire	2-14, 2-39, 2-45	4-9
	✓	✓	✓	✓	✓	C04	Insulation Moisture/Powerhouse (Extra Dip & Bake)	2-14	4-9
	✓	--	✓	✓	✓	C07	Insulation Fungus Protection – No UL	2-14	4-2, 4-9
✓	--	✓	✓	✓	C08	Insulation Tropicalization (Extra Dip & Bake + Fungus Spray)	2-14	4-9	



Special Features – Option Codes (continued)

	1LE2	1MB2	1PC2	1LE6	1PC6 HPS	Codes	Description	For further information, see page(s)	For price information, see page(s)
Terminal Boxes and Leads									
MLFB DIGIT 16	✓	--	--	--	--	0	F-3 Top Mounted Box	2-17, 2-18	4-2, 4-9
	✓	✓	--	--	--	1	C-2 Ceiling	2-17, 2-18	4-2, 4-9
	✓	✓	--	--	--	2	F-2	2-17, 2-18	4-2, 4-9
	✓	✓	✓	--	--	3	F-1	2-17, 2-18	4-2, 4-9
	✓	✓	--	--	--	4	W-6 Shaft Down	2-17, 2-18	4-2, 4-9
	✓	✓	--	--	--	5	W-7 (F-2) Shaft Down	2-17, 2-18	4-2, 4-9
	✓	✓	--	--	--	6	W-5 (F-2) Shaft Up	2-17, 2-18	4-2, 4-9
	✓	✓	--	--	--	7	W-8 Shaft Up	2-17, 2-18	4-2, 4-9
	✓	✓	--	--	--	8	C-1 (F-2) Ceiling	2-17, 2-18	4-2, 4-9
	✓	✓	--	--	--	9-R1A	W-1 (F-2) Wall	2-17, 2-18	4-2, 4-10
	✓	✓	--	--	--	9-R2A	W-2 Wall	2-17, 2-18	4-2, 4-10
	✓	✓	--	--	--	9-R3A	W-3 Wall	2-17, 2-18	4-2, 4-10
	✓	✓	--	--	--	9-R4A	W-4 (F-2) Wall	2-17, 2-18	4-2, 4-10
	--	--	--	✓	✓	1	LHS Mount - View from DE – Drive End	2-17, 2-19	4-10
	--	--	--	✓	✓	2	RHS Mount - View from DE – Drive End Side	2-17, 2-19	4-2, 4-10
	--	--	--	✓	✓	3	Top Mounted Terminal Box from LHS – Drive End Side	2-17, 2-19	4-2, 4-10
--	--	--	✓	✓	4	LHS Mount – View from DE – Non Drive End Side	2-17, 2-19	4-10	
--	--	--	✓	✓	5	RHS Mount – View from DE – Non Drive End Side	2-17, 2-19	4-10	
--	--	--	✓	✓	6	Top Mounted Terminal Box from RHS – Non Drive End Side	2-17, 2-19	4-10	
Short Codes	✓	--	✓	✓	✓	J00	Separate Condulet on Main Box Side for PTC Thermistors	2-17, 2-20	4-10
	--	--	--	✓	✓	J01	Aux Box on Same Side as Main for PTC	2-17, 2-20	4-10
	✓	--	✓	✓	✓	J02	Condulet to Main Box for PTC Thermistors	2-17, 2-20	4-10
	✓	--	✓	✓	✓	J03	Aux Box to Main Box for PTC Thermistors	2-17, 2-20	4-10
	✓	--	✓	✓	✓	J04	Condulet Opposite to Main Box Side for PTC Thermistors	2-17, 2-20	4-10
	✓	--	✓	✓	✓	J05	Aux Box Opposite to Main Box Side for PTC Thermistors	2-17, 2-20	4-10
	--	✓	--	--	--	J06	Explosion Proof Condulet Opposite to Main for PTC	2-17, 2-20	4-10
	--	✓	--	--	--	J07	Explosion Proof Condulet to Main Box for PTC	2-17, 2-20	4-10
	✓	--	✓	✓	✓	J10	Separate Condulet on Main Box Side for Thermostats	2-17, 2-20	4-3, 4-10
	--	--	--	✓	✓	J11	Aux Box on Same Side as Main for Thermostats	2-17, 2-20	4-3, 4-10
	✓	--	✓	✓	✓	J12	Condulet to Main Box for Thermostats	2-17, 2-20	4-3, 4-11
	✓	--	✓	✓	✓	J13	Aux Box to Main Box for Thermostats	2-17, 2-20	4-3, 4-11
	✓	--	✓	✓	✓	J14	Condulet Opposite Side to Main for Thermostats	2-17, 2-20	4-3, 4-11
	✓	--	✓	✓	✓	J15	Aux Box Opposite Side to Main for Thermostats	2-17, 2-20	4-3, 4-11



Special Features – Option Codes (continued)

	1LE2	1MB2	1PC2	1LE6	1PC6 HPS	Codes	Description	For further information, see page(s)	For price information, see page(s)
Terminal Boxes and Leads									
Short Codes	--	✓	--	--	--	J16	Explosion Proof Condulet Opp to Main for Thermostats	2-17, 2-20	4-11
	--	✓	--	--	--	J17	Explosion Proof Condulet to Main Box for Thermostats	2-17, 2-20	4-11
	✓	--	✓	✓	✓	J20	Condulet on Same Side of Main Box for PT1000 Sensors	2-17, 2-20	4-11
	--	--	--	✓	✓	J21	Aux Box on Same Side as Main for PT1000 Sensors	2-17, 2-20	4-11
	✓	--	✓	✓	✓	J22	Condulet to Main Box for PT1000 Sensors	2-17, 2-20	4-11
	✓	--	✓	✓	✓	J23	Aux Box to Main Box for PT1000 Sensors	2-17, 2-20	4-11
	✓	--	✓	✓	✓	J24	Condulet Opposite to Main Box Side for PT1000 Sensors	2-17, 2-20	4-11
	✓	--	✓	✓	✓	J25	Aux Box Opposite Main Box Side for PT1000 Sensors	2-17, 2-20	4-11
	--	✓	--	--	--	J26	Explosion Proof Condulet Opp. to Main Box Side for PT1000 Sensors	2-17, 2-20	4-11
	--	✓	--	--	--	J27	Explosion Proof Condulet to Main Box for PT1000 Sensors	2-17, 2-20	4-11
	✓	--	✓	✓	✓	J50	Separate Condulet on Main Box Side for Space Heaters	2-17, 2-20	4-3, 4-11
	--	--	--	✓	✓	J51	Aux Box on Same Side as Main for Space Heaters	2-17, 2-20	4-3, 4-11
	✓	--	✓	✓	✓	J52	Condulet to Main Box for Space Heaters	2-17, 2-20	4-3, 4-11
	✓	--	✓	✓	✓	J53	Aux Box to Main Box for Space Heaters	2-17, 2-20	4-3, 4-11
	✓	--	✓	✓	✓	J54	Condulet Opposite to Main Box Side for Space Heaters	2-17, 2-20	4-3, 4-11
	✓	--	✓	✓	✓	J55	Aux Box Opposite Main Box Side for Space Heaters	2-17, 2-20	4-3, 4-11
	--	✓	--	--	--	J56	EXP Condulet Opposite to Main Box Side for Space Heaters	2-17, 2-20	4-11
	--	✓	--	--	--	J57	Explosion Proof Condulet to Main Box for Space Heaters	2-17, 2-20	4-12
	✓	✓	✓	✓	✓	J84	Conduit Box Orientation 90° CCW (Entry from DE)	2-17, 2-18	4-3, 4-12
	✓	✓	✓	✓	✓	J85	Conduit Box Orientation 180° CCW (Entry from top)	2-17, 2-18	4-3, 4-12
	✓	✓	✓	✓	✓	J86	Conduit Box Orientation 270° CCW (Entry from NDE)	2-17, 2-18	4-3, 4-12
	✓	✓	✓	✓	✓	K80	BURNDY HYDENT YA Type Terminals	2-17	4-3, 4-12
	--	--	--	✓	✓	K81	Special Cable Leads, 60" Long	2-17, 2-20	4-12
	--	--	--	✓	✓	K82	Special Cable Leads, 120" Long	2-17, 2-20	4-12
	✓	--	✓	--	--	K83	Terminal Block - 3 Lead Only	2-17, 2-20	4-3, 4-12
	✓	■	✓	--	--	K89	Sealed Leads	2-17	4-3, 4-12
✓	■	■	■	■	L01	Cast Iron Main Terminal Box in Lieu of Aluminum	2-17, 2-18	4-3, 4-12	
--	--	--	✓	✓	T00	Main Terminal Box – at 45° Angle	2-17, 2-19	4-3, 4-12	
--	--	--	✓	✓	T25	Aux Terminal Box – at Non Drive End Side	2-17	4-3, 4-12	
✓	--	✓	✓	✓	Y85	Special Cable Length	2-17, 2-20	4-12	



Special Features – Option Codes (continued)

	1LE2	1MB2	1PC2	1LE6	1PC6 HPS	Codes	Description	For further information, see page(s)	For price information, see page(s)
Bearings and Lubrication									
Short Codes	--	--	--	--	✓	A50	Install BRG RTD's-100 Ohm Platinum- Both Ends & Terminal Heads/Block	2-21 , 2-24	4-4 , 4-12
	✓	--	✓	✓	✓	A51	Bearing RTD's-100 Ohm Platinum- Both Ends & Terminal Heads/Block	2-20 , 2-21 , 2-24	4-12
	--	--	✓	--	--	K21	Extra High Thrust	2-21 , 2-23 , 2-36	4-12
	✓	--	--	--	--	L54	Provisions for Oil Mist	2-21	4-12
	✓	--	--	--	--	L55	Oil Mist Ready	2-21	4-12
	✓	✓	✓	✓	✓	L57	MOBIL 28 - High or Low – Special Grease	2-21	4-4 , 4-12
	✓	✓	✓	✓	✓	L58	MOBILITH SHC 100 – Special Grease	2-21	4-4 , 4-12
	✓	--	✓	■	■	L60	ALEMITE and Grease Relief Fitting	2-21	4-4 , 4-12
	✓	✓	✓	✓	■	L61	Insulated Bearing – INSOCOAT (Both Ends)	2-21 , 2-25	4-4 , 4-12
	✓	✓	✓	✓	✓	L64	Insulated Bearing – INSOCOAT (NDE Only)	2-21 , 2-25	4-4 , 4-12
	✓	✓	--	--	--	L65	Roller Instead of Ball Bearings	2-21 , 2-22 , 2-24	4-12
	✓	--	--	✓	✓	L66	Insulated Bearings on Both Ends	2-21 , 2-25	4-13
	✓	--	--	✓	✓	L67	Insulated NDE Only	2-21 , 2-25	4-13
	✓	✓	✓	--	--	L68	Sealed Ball Bearings (Both Ends)	2-21	4-4 , 4-13
	✓	✓	--	✓	✓	L69	Hybrid (Ceramic Ball) Bearings – Both Ends	2-21 , 2-25	4-4 , 4-13
✓	✓	✓	✓	✓	L70	Hybrid (Ceramic Ball) Bearings – NDE	2-21 , 2-25	4-4 , 4-13	
✓	✓	✓	✓	✓	L71	Hybrid (Ceramic Ball) Bearings – DE	2-21 , 2-25	4-4 , 4-13	
Shaft and Seals									
Short Codes	✓	✓	✓	✓	✓	K41	Keyless Shaft	2-26 , 2-27	4-13
	✓	--	--	✓	✓	L29	Shaft Grounding Brush	2-26 , 2-28	4-4 , 4-13
	✓	✓	✓	--	--	L76	Shaft Slinger & O Ring	2-26 , 2-27	4-4 , 4-13
	✓	✓	✓	✓	✓	L79	INPRO/SEAL DE	2-26 , 2-27	4-4 , 4-13
	✓	✓	✓	✓	✓	L80	INPRO/SEAL NDE	2-26 , 2-27	4-4 , 4-13
	✓	✓	✓	✓	✓	L81	INPRO/SEAL Both Ends	2-26 , 2-27	4-4 , 4-13
	✓	✓	✓	--	--	L84	Brass Seal	2-26	4-4 , 4-13
	✓	--	✓	✓	✓	L86	INPRO/SEAL MGS Shaft Grounding – Both Ends	2-26 , 2-28	4-4 , 4-13
	✓	✓	✓	■	■	L87	ORION Labrinth Copper Seal – DE	2-26 , 2-27	4-4 , 4-13
	✓	✓	✓	✓	✓	L88	ORION Labrinth Copper Seal – NDE	2-26 , 2-27	4-4 , 4-13
	✓	✓	✓	--	--	L89	ORION Labrinth Copper Seal – Both Ends	2-26 , 2-27	4-4 , 4-13
	✓	--	--	--	--	M42	Shaft Ring Brush (Steel) – NDE (AEGIS)	2-26 , 2-28	4-13
	✓	✓	✓	--	--	M52	NEMA Std Long Shaft – NDE	2-26 , 2-27	4-13
	✓	✓	✓	--	--	M53	NEMA Std Short Shaft – NDE	2-26 , 2-27	4-13
	✓	✓	✓	✓	✓	M57	(C4140) Carbon Steel Shaft	2-26	4-13
	✓	✓	✓	✓	✓	Y50	Special Shaft on Drive End	2-26 , 2-27	4-13
	✓	✓	✓	✓	✓	Y51	Special Shaft on Non Drive End	2-26 , 2-27	4-13

Special Features – Option Codes (continued)

	1LE2	1MB2	1PC2	1LE6	1PC6 HPS	Codes	Description	For further information, see page(s)	For price information, see page(s)
Frame									
Short Codes	✓	✓	■	✓	✓	K33	Drip Cover	2-29, 2-30	4-5, 4-14
	✓	✓	■	--	--	K34	Lifting Hooks (No Drip Cover)	2-29	4-5, 4-14
	✓	✓	--	■	■	K38	Provisions for Dowel Holes	2-29	4-5, 4-14
	✓	✓	✓	✓	✓	K70	Rotation Arrow Bidirectional (Not for Uni-Directional)	2-29, 2-30	4-5, 4-14
	✓	✓	✓	✓	✓	K71	Rotation Arrow Clockwise (from NDE)	2-29, 2-30	4-5, 4-14
	✓	✓	✓	✓	✓	K72	Rotation Arrow Counterclockwise (from NDE)	2-29, 2-30	4-5, 4-14
	✓	■	■	■	■	L20	Lifting Eyebolt	2-29	4-5, 4-14
	✓	--	✓	✓	✓	L22	Stainless Steel Hardware (Includes T Drain SS)	2-29, 2-31	4-5, 4-14
	✓	✓	✓	✓	✓	L27	Ground Bolts – Qty 2	2-29, 2-31	4-5, 4-14
	✓	--	✓	✓	✓	L45	SS T-Slot Breather Drain	2-29, 2-31	4-5, 4-14
	✓	✓	✓	✓	✓	L46	CROUSE HINDS UL Approved Breather Drain	2-29, 2-31	4-5, 4-14
	--	✓	--	--	--	L90	IP66 Ingress Protection	2-29, 2-31	4-5, 4-14
	✓	--	--	--	--	M09	Aluminum Fan	2-29, 2-30	4-5, 4-14
	✓	--	✓	--	--	M10	Bronze Fan	2-29, 2-30	4-5, 4-14
	✓	✓	--	--	--	M28	Stainless Steel Eyebolt	2-29, 2-31	4-5, 4-14
✓	✓	--	■	■	M39	Vertical Jacking Provisions	2-29	4-5, 4-14	
Rating Plates and Tagging									
Short Codes	✓	✓	✓	✓	✓	M21	Additional Nameplate (without Logos)	2-32, 2-33	4-14
	✓	--	✓	✓	✓	M22	Class I, Division 2 Tag	2-32, 2-33	4-5, 4-14
	✓	✓	✓	✓	✓	M23	Space Heaters Caution Plate	2-32, 2-34	4-5, 4-14
	✓	✓	✓	✓	✓	M24	Lubrication Plate	2-32, 2-34	4-5, 4-14
	✓	✓	✓	--	--	M25	Class II, Division 2	2-32, 2-33, 2-45	4-5, 4-14
	--	✓	--	--	--	M32	Class II, Group E Hazardous Area	2-32, 2-33	4-14
	✓	✓	✓	✓	✓	Y80	Derate-Alt-Amb (Nameplate Change)	2-10, 2-32, 2-34, 2-35	4-5, 4-14
	✓	✓	✓	✓	✓	Y82	Auxiliary Nameplate Max. 40 Characters (Aux Tag)	2-32, 2-34	4-5, 4-14
Ambient and Altitude									
Short Codes	✓	--	✓	✓	✓	B27	+40C to -30C Ambient Temp	2-21, 2-31, 2-35	4-14
	✓	--	✓	✓	✓	B28	+40C to -40C Ambient Temp	2-21, 2-31, 2-35	4-14
	✓	--	✓	✓	✓	B29	+40C to -50C Ambient Temp	2-21, 2-31, 2-35	4-14



Special Features – Option Codes (continued)

	1LE2	1MB2	1PC2	1LE6	1PC6 HPS	Codes	Description	For further information, see page(s)	For price information, see page(s)
Mechanical Design and Accessories									
Short Codes	✓	--	--	--	--	A66	ROBERTSHAW Vibration Detectors, Model 366-D8 120VAC	2-36 , 2-37	4-15
	✓	✓	✓	✓	■	A67	Provision Only for Vibration Sensors (PMC/Beta)	2-36 , 2-37	4-15
	✓	--	✓	--	--	G05	DYNAPAR Encoder HS35R 1024 PPR	2-36 , 2-37	4-15
	✓	--	✓	--	--	G06	C-Face Mounted SLIM Tach Encoder	2-36 , 2-37	4-15
	✓	--	--	--	--	H04	C-Face Mounted Brake	2-36 , 2-38	4-15
	✓	--	✓	✓	✓	K10	IEEE 841 Features	2-27 , 2-36	4-15
	--	--	✓	--	--	K20	API 610	2-23 , 2-36	4-15
	✓	✓	--	--	--	M05	Larger Fan	2-36 , 2-39 , 2-45 , 2-46	4-5 , 4-15
	✓	--	--	--	--	M08	Separately Driven Fan	2-36 , 2-39 , 2-45	4-15
	--	--	✓	--	--	M18	Non-Reverse Ratchet	2-36 , 2-39	4-15
	✓	✓	✓	--	--	M69	Precision Balance	2-36	4-5 , 4-15
	✓	✓	✓	--	--	M70	Extra Precision Balance	2-36	4-5 , 4-15
Paint and Packaging									
Short Codes	✓	✓	✓	✓	✓	B09	Export Packaging Sea Freight – Siemens Standard	2-40	4-6 , 4-15
	✓	✓	✓	✓	✓	B10	Export Packaging Special Export Box	2-40	4-15
	✓	✓	✓	✓	✓	N01	2 Part Epoxy (Industrial–Coastal Low Salt)	2-40 , 2-41	4-15
	✓	✓	✓	✓	✓	N02	3 Part Epoxy (Industrial–Coastal Moderate Salt)	2-40 , 2-41	4-15
	✓	✓	✓	✓	✓	N03	Primer Only	2-40 , 2-41	4-15
	✓	✓	✓	✓	✓	N05	3 Part Epoxy (Coastal–Offshore High Salt)	2-40 , 2-41	4-15
	✓	✓	✓	✓	✓	Y60	Special Color (Provide RAL#)	2-40 , 2-41	4-15
Documentation									
Short Codes	✓	✓	✓	✓	✓	D05	Documentation in Spanish	2-42 , 2-43	4-16
	✓	✓	✓	✓	✓	F00	Certificate of Compliance	2-42 , 2-43	4-6 , 4-16
	✓	✓	✓	✓	✓	F03	Standard Performance Curves	2-42 , 2-43	4-6 , 4-16
	✓	✓	✓	✓	✓	F07	Special Calculated Data	2-42 , 2-43	4-6 , 4-16
	✓	✓	✓	✓	✓	F40	Stall Time Curve (Thermal Limit Curve)	2-42 , 2-43	4-6 , 4-16
	✓	✓	✓	✓	✓	F42	Standard Dimensional Sheet	2-42 , 2-43	4-6 , 4-16
	✓	✓	✓	✓	✓	F43	Non-Standard Dimension Sheet	2-42 , 2-43	4-6 , 4-16
	✓	✓	✓	✓	✓	F44	Conduit Box Dimension Sheet	2-42 , 2-43	4-6 , 4-16
	✓	✓	✓	✓	✓	F45	Wiring Diagram	2-42 , 2-43	4-6 , 4-16
	✓	✓	✓	✓	✓	F46	Instruction and Operation Manual in English	2-42 , 2-43	4-6 , 4-16
	✓	✓	✓	✓	✓	F47	Renewal Parts	2-42 , 2-43	4-6 , 4-16
	✓	✓	✓	✓	✓	F49	Performance Data Sheets	2-42 , 2-43	4-6 , 4-16
	✓	✓	✓	✓	✓	F50	Customer Specific Data Sheets	2-42 , 2-43	4-6 , 4-16



Special Features – Option Codes (continued)

	1LE2	1MB2	1PC2	1LE6	1PC6 HPS	Codes	Description	For further information, see page(s)	For price information, see page(s)
Tests									
Short Codes	✓	✓	✓	✓	✓	F10	Routine Test Report	2-44	4-6, 4-16
	✓	✓	✓	✓	✓	F12	Routine Test Report (Witnessed)	2-44	4-6, 4-16
	✓	✓	✓	✓	✓	F15	Complete Test	2-44	4-6, 4-16
	✓	✓	✓	✓	✓	F17	Complete Test (Witnessed)	2-44	4-6, 4-16
	✓	✓	✓	✓	✓	F20	Routine Test + Vibration	2-44	4-6, 4-16
	✓	✓	✓	✓	✓	F22	Routine Test + Vibration (Witnessed)	2-44	4-6, 4-16
	✓	✓	✓	✓	✓	F27	Performance Load Test (Curve Report)	2-44	4-6, 4-16
	✓	✓	✓	✓	✓	F30	Noise Test	2-44	4-6, 4-16
	✓	✓	✓	✓	✓	F32	Noise Test (Witnessed)	2-44	4-6, 4-16
	✓	✓	✓	✓	✓	F36	Routine Test Report of Electrical Duplicate Design	2-44	4-6, 4-16
	✓	✓	✓	✓	✓	F37	Type Test Report of Electrical Duplicate Design	2-44	4-6, 4-16
	--	✓	--	--	--	F90	IEC EX Certification	2-44	4-16

Legend

✓ Available

■ Standard

CF Consult Factory - NEMA Quotation Team for Price

-- Not Available



Technical Notes

MLFB Structure

MLFB Structure	1	2	3	4	5	6	7	-	8	9	10	11	12	-	13	14	15	16	-Z
Motor Series	1	2	3																
Standard GP, SD Motors	1	L	E																
Division 1 Explosion Proof Motors	1	M	B																
Definite Purpose Motors	1	P	C																
Main Series				4															
NEMA Motors				2															
Next Generation NEMA Motors				6															
Motor Type/Enclosure/Efficiency					5	6	7												
GP100A NP+	1	L	E	2	1	1	1												
GP100A NP	1	L	E	2	1	2	1												
GP100 NP+	1	L	E	2	2	1	1												
GP100 NP	1	L	E	2	2	2	1												
SD100 NP+	1	L	E	2	3	1	1												
SD100 NP	1	L	E	2	3	2	1												
SD100 IEEEE841 NP+	1	L	E	2	4	1	1												
SD100 IEEEE841 NP	1	L	E	2	4	2	1												
SD661	1	L	E	2	4	2	2												
SD10 MS	1	L	E	2	3	0	1												
XP100	1	M	B	2	1	2	1												
XP100 ID1	1	M	B	2	2	2	1												
HP100	1	P	C	2	8	2	2												
LP100	1	P	C	2	8	3	2												
SD200	1	L	E	6	3	2	1												
DP200 HPS	1	P	C	6	5	2	1												
Motor HP and Frame									8	9		11							
Num Number of Poles (Speed)											10								
2 Pole (3000/3600 RPM)											A								
4 Pole (1500/1800 RPM)											B								
6 Pole (1000/1200 RPM)											C								
8 Pole (750/900 RPM)											D								
8/4 Pole (Two Speed)											M								
Winding Design/Voltage/Frequency													12		13				
Mounting																	14		
Winding Protection																		15	
Terminal Box Position																			16
With Additional Options																			-Z

Technical Notes

Voltage and Connection

		140-250 Frames	280-400 Frames	440-5449 Frames	500 Frame	
MLFB DIGITS 12 & 13	11	230V	3 Lead Wye Fig. 2-1	3 Lead Delta Fig. 2-2	N/A	N/A
	12	460V	3 Lead Wye Fig. 2-1	3 Lead Delta Fig. 2-2	6 Lead Delta Fig. 2-3	12 Lead Delta Fig. 2-9
	13	575V	3 Lead Wye Fig. 2-1	3 Lead Delta Fig. 2-2	6 Lead Delta Fig. 2-3	12 Lead Delta Fig. 2-9
	14	230/460 (Suitable for 208V)	9 Lead Wye Fig. 2-4	N/A	N/A	N/A
	16	230/460	9 Lead Wye Fig. 2-4	9 Lead Delta Fig. 2-5	N/A	N/A
	22	PWS 460V 60Hz	N/A	Part Winding Start Fig. 2-6		
	23	PWS 575V 60HZ	N/A	Part Winding Start Fig. 2-6		
	32	Y/D 460V 60Hz	N/A	6 Lead Wye-Start Delta-Run Fig. 2-7		
	33	Y/D 575V 60HZ	N/A	6 Lead Wye-Start Delta-Run Fig. 2-7		
	40	460V Y,YY, 60HZ, 1 Winding Variable Torque	2 Speed - 1 Winding VT Fig. 2-8			N/A
44	575V Y,YY, 60HZ, 1 Winding Variable Torque	2 Speed - 1 Winding VT Fig. 2-8			N/A	
90	200-600V (M1Y 200-460,M2Y 461-600)	As Specified				

Voltage

LV NEMA motors can operate from 200-600V according to the winding selection. Windings up to 230V can only be applied to motors with 75HP or less.

Part-Winding-Start and Wye-Start/ Delta-Run are special windings that help to limit the amount of inrush current at startup. Both options require a special motor starter to operate correctly.

Special voltage, **M1Y**, **M2Y**, can be used for any voltage within the voltage range listed for each.

When used for 50HZ operation the service factor will be 1.0 with the standard HP output. Electrical Data must be calculated and provided by the factory when **M1Y** and **M2Y** are selected. For 50HZ operation at 1.15 S.F. de-rate to the next smaller HP can be requested with option **Y80** (see Rating Plates and Tagging section).

AC NEMA motors are designed with the following tolerances in accordance with NEMA MG-1:

Voltage tolerance: +/-10% of rated voltage

Frequency tolerance: +/- 5% of rated frequency

Voltage & Frequency combined tolerance:
+/-10% (sum of absolute values)

Winding Connection:

140-250 Frame :

Y for single voltage and YYY for dual voltage

280 frame and up:

Δ for single voltage and Δ Δ / Δ for dual voltage

440T frame and up will have 6 lead connection with paired leads for flexibility in connection. Figure 2-3

See Terminal Box and Leads section for additional information on motor leads.



Technical Notes

Voltage and Connection (continued)

Fig. 2-1

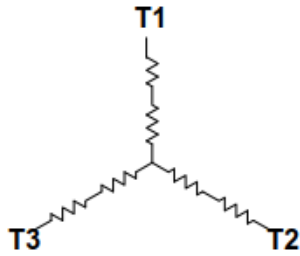

3 LEAD WYE				
LINES			CONN.	
L1	L2	L3		
T1	T2	T3	Y	

Fig. 2-2

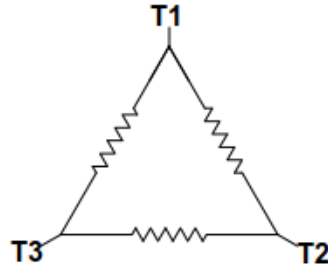

3 LEAD DELTA				
LINES			CONN.	
L1	L2	L3		
T1	T2	T3	Δ	

Fig. 2-3

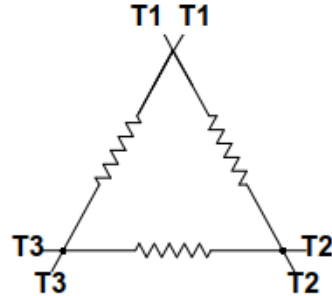

6 LEAD DELTA				
LINES			CONN.	
L1	L2	L3		
T1	T2	T3	Δ	

Fig. 2-4

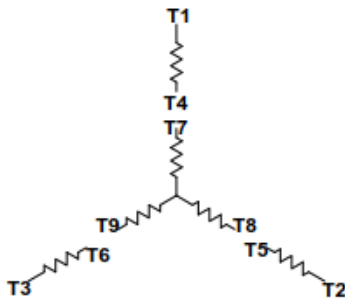

Volts	LINES			CONNECTED TOGETHER	CONN.
	L1	L2	L3		
LOW	T1	T2	T3	T4 T5 T6	YY
HIGH	T1	T2	T3	T4 T7-T5 T8-T6 T9	Y

Fig. 2-5

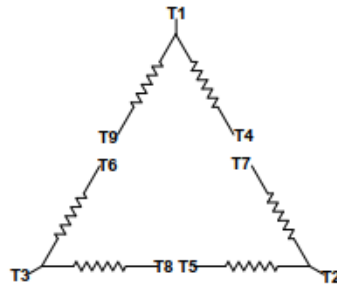

Volts	LINES			CONNECTED TOGETHER	CONN.
	L1	L2	L3		
LOW	T1 T7	T2 T8	T3 T9		ΔΔ
HIGH	T1	T2	T3	T4 T7-T5 T8-T6 T9	Δ

Fig. 2-6

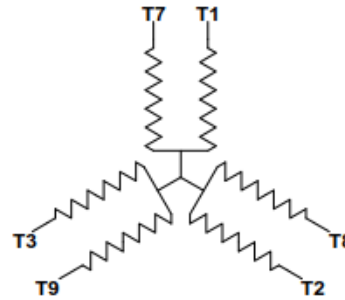

PART WINDING START					
LINES	L1	L2	L3		
START	T1	T2	T3	T7 T8 T9 OPEN	
RUN	T1 T7	T2 T8	T3 T9		

Fig. 2-7

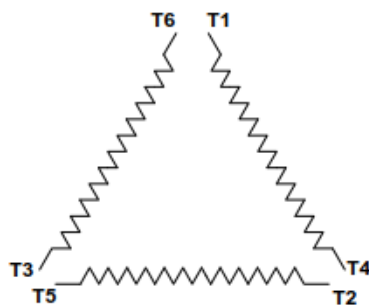

WYE-START DELTA-RUN					
LINES	L1	L2	L3	CONNECTED TOGETHER	CONN.
START	T1	T2	T3	T4 T5 T6	Y
RUN	T1 T6	T2 T4	T3 T5		Δ

Fig. 2-8

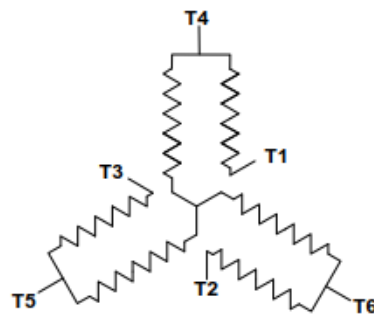

SPEEDS	LINES			CONNECTED TOGETHER	CONN.
	L1	L2	L3		
LOW	T1	T2	T3	T4 T5 T6 OPEN	Y
HIGH	T4	T5	T6	T1 T2 T3 TOGETHER	YY

Fig. 2-9

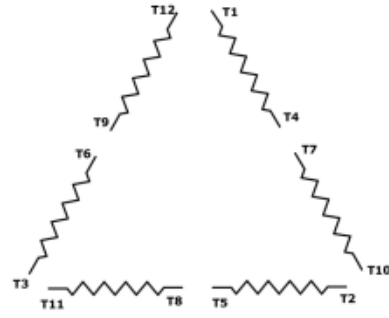

12 LEAD DELTA		
LINES	CONNECT TOGETHER	CONN.
L1	T12 - T7 - T6 - T1	ΔΔ
L2	T10 - T8 - T4 - T2	
L3	T11 - T9 - T5 - T3	

Technical Notes

Mounting

	1LE2	1MB2	1PC2	1LE6	1PC6 HPS	Codes	Description
MLFB DIGIT 14	✓	✓	--	--	--	A	Foot Mount
	✓	✓	--	--	--	E	C - Face with Feet
	✓	✓	--	--	--	F	D - Flange with Feet
	✓	✓	--	--	--	G	C - Face without Feet
	✓	✓	--	--	--	H	D - Flange without Feet
	✓	✓	--	--	--	L	C - Face without Feet with Drip Cover and Lifting Hooks
	✓	✓	--	--	--	M	D - Flange without Feet with Drip Cover and Lifting Hooks
	✓	✓	--	--	--	N	C - Face with Feet with Drip Cover
	✓	✓	--	--	--	P	D - Flange with Feet with Drip Cover
	--	--	✓	--	--	T	P-Base without Feet with Drip Cover and Lifting Hooks
	--	✓	--	--	--	V	CH - Flange w Feet with Drip Cover and Lifting Hooks
	--	✓	--	--	--	W	CH - Flange with Feet
	--	✓	--	--	--	X	CH - Flange without Feet
	--	✓	--	--	--	Y	CH - Flange without Feet with Drip Cover and Lifting Hooks
	--	--	--	✓	✓	A	Foot Mounted (Horizontal IMB3)
	--	--	--	✓	✓	C	Foot Mounted Vertical Shaft-Down without Canopy (IMV5)
	--	--	--	✓	✓	D	Foot Mounted Vertical Shaft-Up (IMV6)
	--	--	--	✓	✓	J	Foot Mounted D-Flange Horizontal (IMB35 – F1/F2/F3)
	--	--	--	✓	✓	R	Foot Mounted D-Flange Vertical Shaft-Down – W6/W7/W12
	--	--	--	✓	✓	S	Foot Mounted D-Flange Vertical Shaft-Up – W5/W8/W11

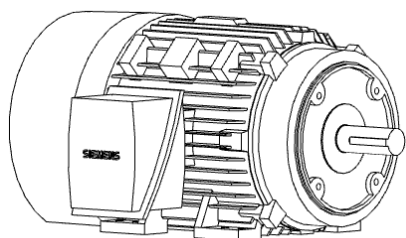

C-Face Foot Mount

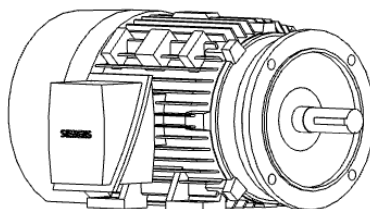

D-Flange Foot Mount

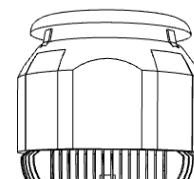

Vertical with Drip Cover



Technical Notes

Mounting (continued)

Flange Mounting

The drive end bearing housing can be replaced with flange mounting for direct coupling to the driven equipment. Flanges can be supplied with or without feet and as vertical or horizontal as required by the application. S449 frame must use the motor feet as support with flange mounting in either vertical or horizontal mounting positions.

Frame size 500 is in development for option without feet. Foot mounted motors can be offered with self-supporting D-flange on request, Contact Siemens Low Voltage Motor Quotation Team for a quotation.

C-Face

The NEMA C-face has threaded holes in the flange and the mounting hardware will be introduced from the driven equipment side. The C-face can be added to a stock motor as a modification where applicable.

CH flange is a standard C-face design in the next smaller size. The CH flange is only available for XP motors in frame size 180.

D-Flange

The NEMA D-flange will have through holes that are unthreaded. The D-Flange can be added to stock motors 140-250 frame as a modification where applicable and can be built as custom on all frames. Note: D-flange is not available on XP motors in frames 140-250.

Notes:

- D-Flange modification on frames 280-449 will result in non-standard usable shaft length when modified from stock.
- D-flange is not available on XP motors in frames 140-250.
- Round frame motors are only stocked in frames 140-250 and can be custom built up to 449 frames.

Technical Notes

Winding Protection

	1LE2	1MB2	1PC2	1LE6	1PC6 HPS	Codes	Description
MLFB DIGIT 15	✓	✓	✓	✓	✓	A	No Protection
	✓	✓	✓	✓	✓	B	PTC 3 Embedded, 1 Per Phase
	✓	✓	✓	✓	✓	C	PTC 6 Embedded, 2 Per Phase
	✓	✓	✓	✓	✓	G	Thermostats Normally Closed, Temp Code T3C, 1 Per Phase
	--	--	--	✓	✓	H	Thermostats Normally Closed, Temp Code T3 - 200°C, 1 Per Phase
	✓	✓	✓	✓	✓	J	Thermocouples Coil Head
	✓	✓	✓	✓	✓	K	Stator RTD's 100-Ohm Platinum w Aux Box-Terminal Strip 2/Phase
	✓	✓	✓	✓	✓	L	Winding Protection - G + K
	✓	✓	✓	✓	✓	M	Winding Protection - H + K
	✓	✓	✓	✓	✓	P	PT1000, 2 Embedded Temperature Sensors
Short Codes	✓	--	✓	--	--	A40	Space Heaters 115V Single Phase
	✓	--	✓	--	--	A41	Space Heaters 230V Single Phase
	✓	--	✓	--	--	A42	Space Heaters 115V Single Phase, Division 2
	--	✓	--	--	--	A43	Space Heaters 115V Single Phase Explosion Proof
	✓	--	✓	--	--	A44	Space Heaters 230V Single Phase, Division 2
	--	✓	--	--	--	A45	Space Heaters 230V Single Phase Explosion Proof
	✓	✓	✓	✓	✓	A46	Space Heaters 115V Single Phase, Max Temp 160°C
	✓	✓	✓	✓	✓	A47	Space Heaters 230V Single Phase, Max Temp 160°C
	✓	✓	✓	--	--	A90	Control Module
	✓	✓	✓	■	■	C00	Insulation Class H
	✓	✓	✓	✓	✓	C01	Insulation Vacuum Pressure Impregnation (VPI)
	✓	✓	✓	✓	✓	C03	Spike Resistant Wire
	✓	✓	✓	✓	✓	C04	Insulation Moisture/Powerhouse (Extra Dip & Bake)
	✓	--	✓	✓	✓	C07	Insulation Fungus Protection - No UL
✓	--	✓	✓	✓	C08	Insulation Tropicalization (Extra Dip & Bake + Fungus Spray) – No UL	

Winding Insulation

Siemens NEMA stator is random wound and insulated with Class F insulation system which is compliant with NEMA MG-1 part 31 and is rated for 155 deg C. Spike resistant wire, **C03**, can be used to meet those more stringent specifications that require part 31 to be exceeded. The stator is protected from moisture with acrylic impregnation though a dip and bake process. The stator is designed to have a temp rise no greater than class B at nameplate horsepower.

Class H insulation, **C00**, is rated for 180 deg C and may be used to better protect the stator when the temp rise may be higher due to ambient conditions or harsher VSD applications. With Class H insulation the lead material will remain Class F. Frame size 500 will have Class H insulation as a standard feature.

Moisture Powerhouse (extra dip and bake), **C04**, adds an extra layer of varnish to the winding for added protection against moisture. Vacuum Pressure Impregnation (VPI), **C01**, is an alternative to the standard dip and bake process. VPI uses a vacuum system to pull the varnish into the winding to reduce air bubbles in the varnish. Fungus protection, **C07**, **C08**, is an anti-fungal spray that is applied to the windings after the dip and bake process to help reduce fungus from growing on the windings during storage prior to operation.



Technical Notes

Winding Protection (continued)

Space Heaters

Space heaters help to reduce the humidity inside the motor during idle times of operation and storage. Siemens uses flexible silicone rubber space heaters that have been proven to provide long life which either meets or exceeds the overall life of the AC induction motor. Space heaters will have wattage corresponding to the voltage and motor size as seen in Table 4-2 and will have leads to the main box as standard or an aux box as an option with leads marked per Figure 4-1.

Siemens now offers low temp space heaters rated for a max surface temperature of 160 deg C for use in safe area, Division 2, or Division 1 certified motors. The heaters can be configured for operation on 115V supply, **A46**, or 230V supply, **A47**.

Additional space heater options (soon to be phased out) are area classification specific.

- Safe Area: Configured for operation on 115V supply, **A40**, or 230V supply, **A41**.
- Division 2: Configured for operation on 115V supply, **A42**, or 230V supply, **A44**.
- Division 1: Configured for operation on 115V supply, **A43**, or 230V supply, **A45**.

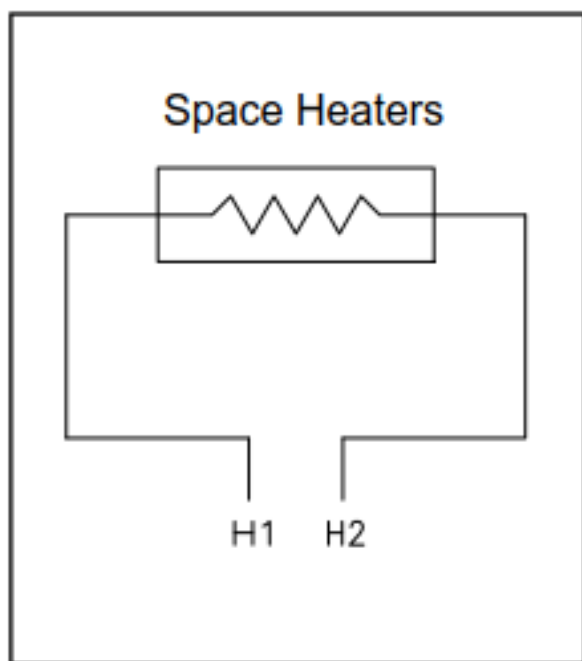

Fig. 4-1

Order Code	Frame	Voltage	Qty	Size	Watts
A40, A42, A43, A46	140-180	115	1	1 x 15	30
A41, A44, A45, A47	140-180	230	1	1 x 15	30
A40, A42, A43, A46	210	115	1	1 x 20	40
A41, A44, A45, A47	210	230	1	1 x 20	40
A40, A42, A43, A46	250	115	1	1 x 25	50
A41, A44, A45, A47	250	230	1	1 x 25	50
A40, A42, A43, A46	280-360	115	1	2 x 24	48
A41, A44, A45, A47	280-360	230	2	2 x 12	48
A40, A42, A43, A46	400-S449	115	2	2.5 x 20	100
A41, A44, A45, A47	400-S449	230	2	2.5 x 20	100
A46	FS500	115	2	2.5 x 20	100
A47	FS500	230	2	2.5 x 20	100

Table 4-1

Technical Notes

Winding Protection (continued)

Winding temperature protection

Thermostats, **MLFB Position 15 "G"**, are supplied as normally closed. When the temperature of the motor reaches the rated temperature of the device, the switch will open and cause a trip condition. Thermostats will have leads to the main box as standard or an aux box as an option with leads marked per Figure 4-2.

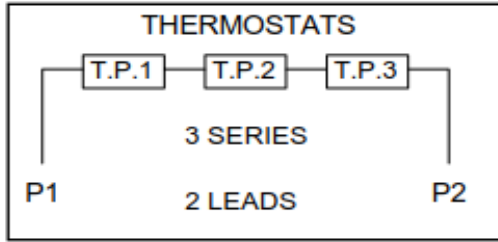

Fig. 4-2

PTC (positive temperature coefficient) thermistors, **MLFB Position 15 "B or C"**, are resistive devices that increase in resistance as the temperature increases. They are set to jump to a very high resistance at a rated temperature. Options are available to have one per phase for trip only, "B", or two per phase for alarm and trip, "C". Thermostats will have leads to the main box as standard or an aux box as an option with leads marked per Figure 4-3 and Figure 4-4.

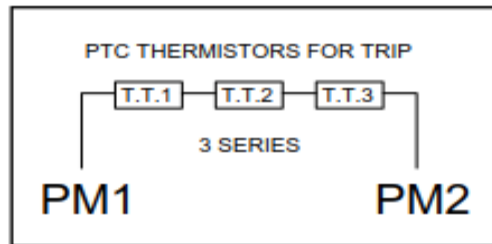

Fig. 4-3

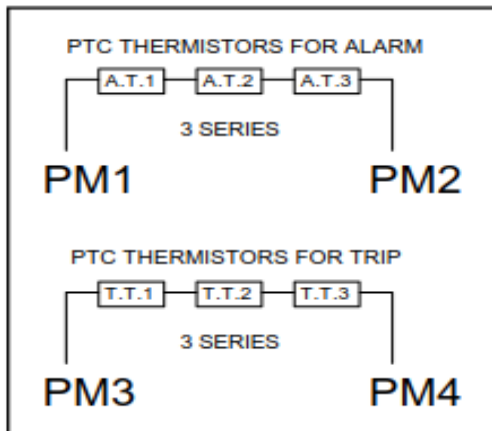

Fig. 4-4

Stator RTDs, **MLFB Position 15 "K"**, are PT100 resistive thermal devices that can be used to monitor the temperature of the motor based on the measured resistance of the device. The resistance range will be 100 ohms at 0 degrees C and increase at a rate of .385 ohms per degree C. RTDs are supplied with two sets per phase (one set active and one set as spares) embedded in the DE end turn of the winding. This option also includes an aux box with a terminal strip with terminals marked per Figure 4-5.

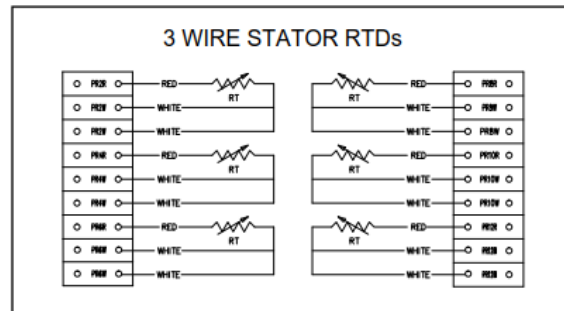

Fig. 4-5

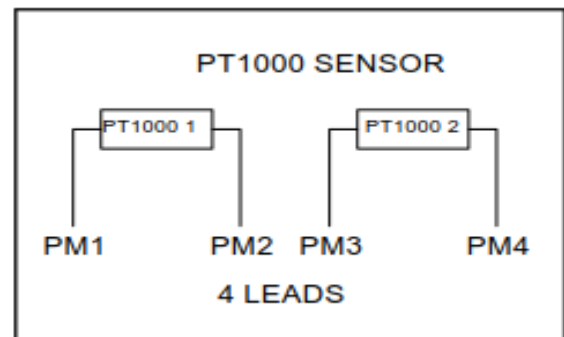

Fig. 4-6

PT1000 sensors, **MLFB Position 15 "P"**, function like the PT100 stator RTDs. The resistance range for the PT1000 sensors is 1000 ohms at 0 degrees C and increases at a rate of 3.85 ohms per degree C. This option comes with two independent sensors (one active and one spare) embedded in the DE end turn of the winding. PT1000 sensors will have leads to the main box as standard or an aux box as an option with leads marked per Figure 4-6.



Technical Notes

Terminal Boxes and Leads

	1LE2	1MB2	1PC2	1LE6	1PC6 HPS	Codes	Description
MLFB DIGIT 16	✓	--	--	--	--	0	F-3 Top Mounted Box
	✓	✓	--	--	--	1	C-2 Ceiling
	✓	✓	--	--	--	2	F-2
	✓	✓	✓	--	--	3	F-1
	✓	✓	--	--	--	4	W-6 Shaft Down
	✓	✓	--	--	--	5	W-7 (F-2) Shaft Down
	✓	✓	--	--	--	6	W-5 (F-2) Shaft Up
	✓	✓	--	--	--	7	W-8 Shaft Up
	✓	✓	--	--	--	8	C-1 (F-2) Ceiling
	✓	✓	--	--	--	9-R1A	W-1 (F-2) Wall
	✓	✓	--	--	--	9-R2A	W-2 Wall
	✓	✓	--	--	--	9-R3A	W-3 Wall
	✓	✓	--	--	--	9-R4A	W-4 (F-2) Wall
	--	--	--	✓	✓	1	LHS Mount - View from DE -Drive End
	--	--	--	✓	✓	2	RHS Mount - View from DE -Drive End Side
	--	--	--	✓	✓	3	Top Mounted Terminal Box from LHS -Drive End Side
--	--	--	✓	✓	4	LHS Mount - View from DE -Non Drive End Side	
--	--	--	✓	✓	5	RHS Mount - View from DE -Non Drive End Side	
--	--	--	✓	✓	6	Top Mounted Terminal Box from RHS -Non Drive End Side	
Short Codes	✓	--	✓	✓	✓	Jx0	Separate Condulet on Main Box Side for PTC
	--	--	--	✓	✓	Jx1	Aux Box on Same Side as Main Box Side for PTC
	✓	--	✓	✓	✓	Jx2	Condulet to Main Box for PTC
	✓	--	✓	✓	✓	Jx3	Aux Box to Main Box for PTC
	✓	--	✓	✓	✓	Jx4	Condulet Opp Side to Main Box Side for PTC
	✓	--	✓	✓	✓	Jx5	Aux Box Opp Side to Main Box Side for PTC
	--	✓	--	--	--	Jx6	Explosion Proof Condulet Opp Side for PTC
	--	✓	--	--	--	Jx7	Explosion Proof Condulet to Left of Main Box
	✓	✓	✓	✓	✓	J84	Conduit Box Orientation 90° CCW (Entry from DE)
	✓	✓	✓	✓	✓	J85	Conduit Box Orientation 180° CCW (Entry from Top)
	✓	✓	✓	✓	✓	J86	Conduit Box Orientation 270° CCW (Entry from NDE)
	✓	✓	✓	✓	✓	K80	BURNDY HYDENT YA Type Terminals
	--	--	--	✓	✓	K81	Special Cable Leads, 60" Long
	--	--	--	✓	✓	K82	Special Cable Leads, 120" Long
	✓	--	✓	--	--	K83	Terminal Block - 3 Lead Only
	✓	■	✓	--	--	K89	Sealed Leads
	✓	■	■	■	■	L01	Cast Iron in Lieu of Aluminum
--	--	--	✓	✓	T00	Main Terminal Box - at a 45° Angle	
--	--	--	✓	✓	T25	Aux Terminal Box - at Non Drive End Side	
✓	--	✓	✓	✓	Y85	Special Cable Length	



Technical Notes

Terminal Boxes and Leads (continued)

Main Terminal Boxes

The main conduit box is diagonally split with a single entrance hole (see drawing section for standard entry hole size) with internal grounding lug provided as standard. The standard terminal box will have a volume that is greater than required by NEMA/ NEC.

Terminal Box Material		
Motor Type	Frame	Material
GP, GPA	140-250	Aluminum
GP	280-400	Stamped Steel
GP	440	Cast Iron
SD, XP, Definite purpose	All	Cast Iron

Table 5-1

Cast iron terminal box is available as an option, **L01**, on general purpose motors that are supplied with stamped steel box as standard. Explosion proof motors have special round style, cast iron explosion proof terminal box with a rabbet fit cover. Severe Duty motors will be supplied with a gasket between conduit box and frame and between cover and base.

The main terminal box position is defined by the 16th position of the MLFB. Foot mounted Cast iron frame motor in 1LE2, 1MB2, 1PC2 can have the terminal box located on the left or right of the frame only (Reference Figure 5-1). The 1LE6, 1PC6 and aluminum frame 1LE2 motors have the option for top mounted terminal box. The connection entry will be facing the motor feet as standard and can be rotated in 90-degree increments in the field or by ordering with options **J84, J85, J86**. Round Frame motors (without feet) will have the terminal box positioned in relation to the motor condensation drains (drains will be in the lowest position).

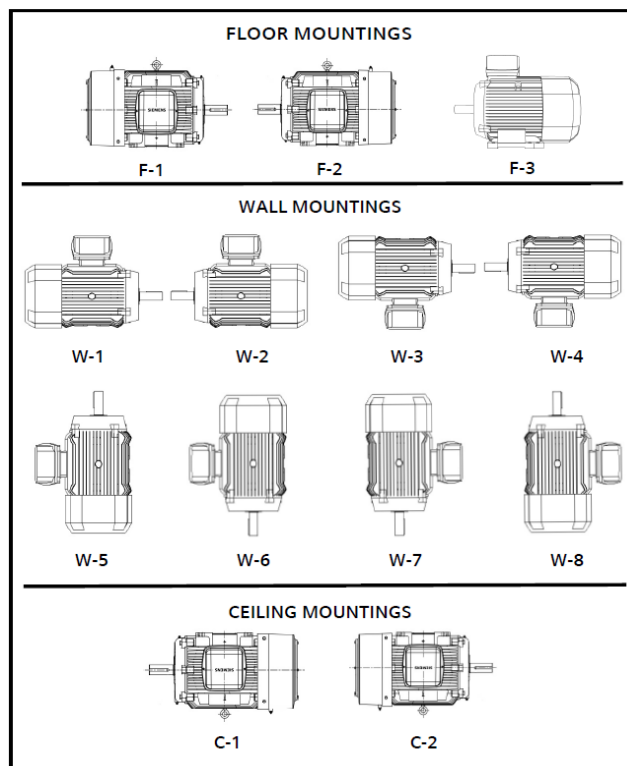

Figure 5-1



Technical Notes

Terminal Boxes and Leads (continued)

The new SD200 frame size 500 motor has a variety of terminal box mounting options. There are 4 locations on the frame where the main box or auxiliary boxes can be mounted. The motors will come as standard with the box on the DE at a 90

deg angle and can be modified to 45 deg, **T00**, with a simple conversion. See figure 5-2 for illustrations of terminal box mounting possibilities and the corresponding 16th digit of the MLFB.

SD200 TERMINAL BOX MOUNTING POSITIONS

MLFB DIGIT 16	1	LHS mount - view from DE -Drive End
	2	RHS mount - view from DE -Drive End side
	3	Top mounted terminal box from LHS -Drive End side
	4	LHS mount - view from DE -Non Drive End side
	5	RHS mount - view from DE -Non Drive End side
	6	Top mounted terminal box from RHS -Non Drive End side

DRIVE END VIEWS

3, 6

1, 4

2, 5

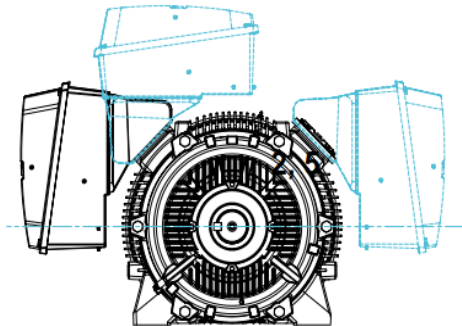

TOP VIEW

5

2

6

3

4

1

1, 4
-Z T00

2, 5
-Z T00

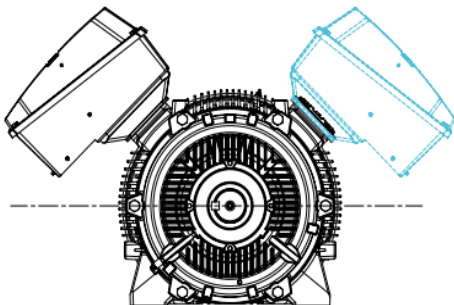

Figure 5-2

Technical Notes

Terminal Boxes and Leads (continued)

Auxiliary Boxes

Auxiliary terminal boxes are available for accessories included in the motor selection. The auxiliary box can be attached to the motor frame or to the side of the main terminal box. Aux box, **Jx1**, **Jx3**, **Jx5**, will be a cast iron auxiliary box. Condulet, **Jx0**, **Jx2**, **Jx4** is an aluminum electrical condulet with a steel cover. The explosion proof condulet, **Jx6**, **Jx7** is a UL approved explosion proof box that has a fully threaded cover. The auxiliary box option

should be selected according to the accessory that it will be paired with. Stator RTDs will come with an aux box with a terminal strip included as standard. The aux box will be on the same side as the main box for the 1LE6, 1PC6 motors and opposite to main for the 1LE2, 1MB2, and 1PC2 motors. Bearing RTDs, **A51**, does not require an auxiliary terminal box, as it comes standard with terminal heads on each bearing housing.

	PTC Thermistors	Thermostats	PT1000 Sensors	Space Heaters
Condulet on Frame (Same Side as Main, DE)	J00	J10	J20	J50
Auxiliary Box on Frame (Same Side Main) *SD200 Only	J01	J11	J21	J51
Condulet on Main Boxes (NDE Side)	J02	J12	J22	J52
Auxiliary Box on Main Box (NDE Side)	J03	J13	J23	J53
Condulet on Frame (Opposite to Main)	J04	J14	J24	J54
Auxiliary Box on Frame (Opposite to Main)	J05	J15	J25	J55
Explosion Proof Condulet on Frame (Opposite to Main)	J06	J16	J26	J56
Explosion Proof Condulet on Main Box	J07	J17	J27	J57

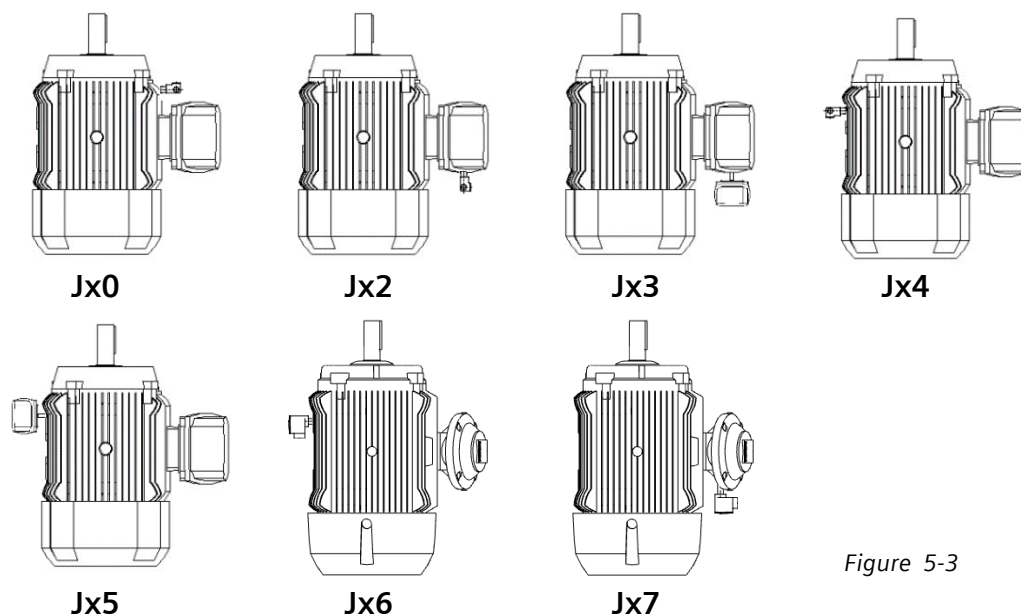

Figure 5-3

Terminal Leads

All NEMA motors come standard with flying leads (no terminal block) terminated using ring terminals. The leads are Class F insulated and identified with permanent marking. Terminal block, **K83**, is available on motors up to 360 frame and only with 3 leads. As standard terminal leads will be of sufficient length to execute the

termination to the power leads inside the terminal box. Special cable length, **Y85**, is available on 1LE2 and 1PC2 severe duty motors and may be used to extend the leads up to 120" outside of the motor frame. The SD200 frame size 500 can be supplied with leads extended to 60", **K81**, or 120", **K82**, outside the motor frame.



	1LE2	1MB2	1PC2	1LE6	1PC6 HPS	Codes	Description
Short Codes	-	-	-	-	✓	A50	Install BRG RTD's-100 Ohm Platinum - Both Ends & Terminal Heads/Block
	✓	-	✓	✓	✓	A51	BRG RTD's-100 Ohm Platinum - Both Ends & Terminal Heads/Block
	-	-	✓	-	-	K21	Extra High Thrust
	✓	-	-	-	-	L54	Provisions for Oil Mist
	✓	-	-	-	-	L55	Oil Mist Ready
	✓	✓	✓	✓	✓	L57	MOBIL 28-High or Low - Special Grease
	✓	✓	✓	✓	✓	L58	MOBILITH SHC 100 -Special Grease
	✓	-	✓	■	■	L60	ALEMITE and Grease Relief Fitting
	✓	✓	✓	✓	✓	L61	SKF INSOCOAT Bearing Both Ends
	✓	✓	✓	✓	✓	L64	SKF INSOCOATE Bearing NDE
	✓	✓	-	-	-	L65	Roller Instead of Ball
	✓	-	-	✓	✓	L66	Insulated Bearings on Both Ends
	✓	-	-	✓	✓	L67	Insulated NDE Only
	✓	✓	✓	-	-	L68	Sealed Brgs for Ball
	✓	✓	-	✓	✓	L69	Hybrid (Ceramic Ball) Bearings – Both Ends
	✓	✓	✓	✓	✓	L70	Hybrid (Ceramic Ball) Bearings – NDE
✓	✓	✓	✓	✓	L71	Hybrid (Ceramic Ball) Bearings – DE	

Lubrication

Standard lubrication for All Siemens LV NEMA motors is EXXONMOBIL POLYREX EM (Polyurea-based grease).

MOBIL 28 Grease, **L57**, has a wide temperature range with a clay base thickener ideal for low ambient conditions below minus 29C. This option is supplied as standard for low ambient option codes **B27**, **B28**, and **B29**.

MOBILITH SCH 100, **L58**, is a Lithium base alternative to our standard POLYREX EM.

Grease inlet (Alemite fitting) is standard on GP100 in frame 280 and larger, and all SD, XP, and DP NEMA products. Grease fittings are not possible on the GP100A product line. SD100 IEEE motors include Alemite and automatic grease relief fittings as standard, **L60** option is available for other severe duty motors.

Oil mist ready, **L55**, and Provisions for oil mist, **L54**, are possible on Severe Duty motors (SD100/SD100IEEE) 280 to 440 Frames and SD10MS 280

to 440 Frames Horizontal Foot Mount only. Bearings must be single shield ball bearings with shields to inboard side. Motor leads are sealed to prevent mist from entering conduit box and lead material used is resistant to oil mist. Oil mist ready will only have enough grease in the bearings to complete the routine test. Provisions for oil mist will be supplied with grease in the bearing housing which must be expelled prior to switching to oil mist lubrication. Motors with oil mist options will not have grease fittings or grease relief.

Sealed Bearings, **L68**, are greased for life bearings and will not require re-lubrication. Sealed bearings are not available on motors with IEEE 841.

Bearings

Siemens standard re-greasable bearings have an L10 bearing life of 100,000 hours for direct coupled applications and 50,000 hours for belted applications when properly sized for the application and with proper maintenance. See Table 6-1 for standard bearings sizes and with option **L65**.

Technical Notes

Bearings and Lubrication (continued)

SIMOTICS NEMA Standard Bearing Information				
Motor Type	Frame	Standard Bearing Size DE	Standard Bearing Size NDE	Option L65 Bearing Size DE
GP100, GP100A, SD10 MS	140T	6205 ZZ C3 S0	6205 ZZ C3 S0	NA
SD100, SD100 IEEEE, XP100	140T	6205 Z C3 S0	6205 Z C3 S0	NA
HP100	180HP	6206 C3 S0	6206 C3 S0 DB	NA
JP100 (XP)	180JP	6007 Z C3 S0	6206 Z C3 S0	NA
LP100	180LP	6206 C3 S0	7306 BG DB	NA
GP100, GP100A, SD10 MS	180T	6206 ZZ C3 S0	6206 ZZ C3 S0	NA
SD100, SD100 IEEEE, XP100	180T	6206 Z C3 S0	6206 Z C3 S0	NA
HP100	210HP	6209 C3 S0	6309 C3 S0 DB	NA
LP100	210LP	6209 C3 S0	7309 BG DB	NA
GP100, GP100A	210T	6208 ZZ C3 S0	6208 ZZ C3 S0	NA
SD10 MS	210T	6208 ZZ C3 S0	6208 ZZ C3 S0	NU 208
SD100, SD100 IEEEE, XP100	210T	6208 Z C3 S0	6208 Z C3 S0	NU 208
SD661	R210T	NU 208	6208 Z C3 S0	Standard
XPJP	215JP	6009 Z C3 S0	6208 Z C3 S0	NA
HP100	250HP	6309 C3 S0	6309 C3 S0 DB	NA
LP100	250LP	6309 C3 S0	7309 BG DB	NA
GP100, GP100A	250T	6209 ZZ C3 S0	6209 ZZ C3 S0	NA
SD100, SD100 IEEEE, XP100, SD10 MS	250T	6309 Z C3 S0	6309 Z C3 S0	NU 309
SD661	R250T	NU 309	6309 Z C3 S0	Standard
HP100	280HP	6310 Z C3 S0	6312 Z C3 S0	NA
LP100	280LP	6312 Z C3 S0	7311 BG DB	NA
SD661	R280T	NU 310	6310 Z C3 S0	Standard
GP100	280T/TS	6310 Z C3 S0	6210 ZZ C3 S0	NA
SD100, SD100 IEEEE, XP100, SD10 MS	280T/TS	6310 Z C3 S0	6310 Z C3 S0	NU 310
HP100	320HP	6312 Z C3 S0	6314 Z C3 S0	NA
LP100	320LP	6312 Z C3 S0	7311 BG DB	NA
SD661	R320T	NU 312	6312 Z C3 S0	Standard
GP100	320T/TS	6312 Z C3 S0	6210 ZZ C3 S0	NA
SD100, SD100 IEEEE, XP100, SD10 MS	320T/TS	6312 Z C3 S0	6312 Z C3 S0	NU 312
HP100	360HP	6316 Z C3 S0	6316 Z C3 S0	NA
LP100	360LP	6316 Z C3 S0	7311 BG DB	NA
SD661	R360T	NU 314	6314 Z C3 S0	Standard
GP100	360T/TS	6314 Z C3 S0	6214 ZZ C3 S0	NA
SD100, SD100 IEEEE, XP100, SD10 MS	360T/TS	6314 Z C3 S0	6314 Z C3 S0	NU 314
LP100	400LP	6316 Z C3 S0	7311 BG DB	NA
GP100	400T/TS	6316 Z C3 S0	6214 ZZ C3 S0	NA
SD100, SD100 IEEEE, XP100, SD10 MS, HP100	400T/TS	6316 Z C3 S0	6316 Z C3 S0	NU 316
HP100	440HP	6316 Z C3 S0	6318 Z C3 S0	NA
LP100	440LP	6316 Z C3 S0	7311 BG DB	NA
GP100	440TS	6316 Z C3 S0	6216 ZZ C3 S0	NA
SD100, SD100 IEEEE (4,6,8 Pole), XP100, SD10 MS	440TS	6316 Z C3 S0	6316 Z C3 S0	NA
SD100 IEEEE (2 Pole)	440TS	6318 Z C3 S0	6316 Z C3 S0	NA
GP100, SD100, SD100 IEEEE, XP100	R444/445T	NU 318	6316 Z C3 S0	Standard
GP100, SD100, SD100 IEEEE, XP100	R447/449T	NU 320	6316 Z C3 S0	Standard
SD200 (2 Pole)	509-5013S	6316 Z C3 S0	6316 Z C3 S0	NA
DP200 (2 Pole)	509-5013S	6316 Z C3 S0	INSOCOAT 6316-Z/C3VL0241	NA
SD200 (4,6 Pole)	509-5013/S	6322 Z C3 S0	6322 Z C3 S0	NA
GP100	440T	6318 Z C3 S0	6216 ZZ C3 S0	NA
SD100, SD100 IEEEE, XP100, SD10 MS	440T	6318 Z C3 S0	6316 Z C3 S0	NA
SD200	R509-R5013	NU 322	6322 Z C3 S0	Standard
SD100, SD100 IEEEE	RS449LS	NU 320	6315 Z C3 S0	Standard
SD100, SD100 IEEEE	S449SS	6315 Z C3 S0	6315 Z C3 S0	NA

Table 6-1



Technical Notes

Bearings and Lubrication (continued)

Vertical solid shaft motors, HP100 and LP100, thrust values are published with a bearing life of one year. Extra High Thrust, **K21**, changes the NDE thrust bearings to tandem configuration on the LP100 to allow for more down thrust to be considered (see Table 6-2 for new thrust values). API 610, **K20**, does not allow for bearings in tandem and cannot be used with **K21**. With API610 the thrust bearing must be located on the NDE and have a minimum bearing life of 3 years. See thrust values for 3 year bearing life in table 6-2.

LP100 Thrust Table											
Horse Power	Pole	Frame Size	Max radial force (lb)	Standard Thrust (3 years)		Standard Thrust (1 year)		Code K21 Extra High DOWN thrust (3 years)		Code K21 Extra High DOWN thrust (1 year)	
				Down thrust (lb)	Up thrust (lb)	Down thrust (lb)	Up thrust (lb)	Up thrust (lb)	Down thrust (lb)	Up thrust (lb)	Down thrust (lb)
3	2	182LP	24	743	750	1087	1095	225*	1533	328*	2227
3	4	182LP	39	927	935	1361	1369	281*	1923	410*	2797
3	6	213LP	51	1847	1870	2702	2725	561*	3806	817*	5527
5	2	184LP	34	731	738	1075	1082	222*	1521	324*	2215
5	4	184LP	45	917	923	1351	1357	277*	1913	407*	2787
5	6	215LP	62	1831	1851	2685	2705	555*	3790	811*	5510
7.5	2	213LP	40	1268	1288	1860	1880	386*	2626	564*	3819
7.5	4	213LP	66	1582	1605	2328	2351	482*	3293	705*	4796
7.5	6	254LP	84	1794	1825	2648	2680	548*	3753	803*	5473
10	2	215LP	50	1256	1277	1848	1868	383*	2614	560*	3807
10	4	215LP	73	1571	1593	2317	2338	478*	3282	701*	4785
10	6	256LP	98	1775	1805	2629	2659	542*	3733	797*	5454
15	2	254LP	75	1218	1251	1811	1843	375*	2577	553*	3769
15	4	254LP	95	1533	1562	2279	2309	469*	3244	692*	4747
15	6	284LPH	95	2491	2548	3682	3738	764*	5221	1121*	7618
20	2	256LP	92	1197	1232	1789	1824	370*	2555	547*	3748
20	4	256LP	120	1501	1534	2247	2281	460*	3212	684*	4715
20	6	286LPH	120	2455	2516	3645	3705	755*	5184	1111*	7581
25	2	284LPH	65	1716	1768	2541	2593	530*	3608	777*	5271
25	4	284LPH	108	2133	2193	3172	3233	658*	4517	969*	6611
25	6	324LP	155	2379	2475	3569	3665	743*	5108	1099*	7505
30	2	286LPH	78	1698	1753	2523	2578	526*	3591	773*	5253
30	4	286LPH	116	2119	2177	3158	3217	653*	4503	965*	6597
30	6	326LP	172	2351	2450	3541	3640	735*	5080	1091*	7478
40	2	324LP	98	1655	1726	2480	2551	518*	3548	765*	5210
40	4	324LP	140	2053	2139	3093	3179	642*	4438	953*	6532
40	6	364LP	186	2304	2414	3494	3605	724*	5033	1081*	7430
50	2	326LP	105	1641	1710	2466	2535	513*	3533	760*	5196
50	4	326LP	180	1994	2095	3034	3135	629*	4378	940*	6473
50	6	365LP	208	2265	2376	3455	3565	713*	4994	1069*	7391
60	2	364LP	152	1561	1670	2386	2495	501*	3453	748*	5115
60	4	364LP	214	1926	2057	2965	3097	617*	4310	928*	6404
60	6	404LP	274	2160	2310	3351	3500	693*	4890	1050*	7287
75	2	365LP	175	1527	1640	2352	2465	492*	3419	739*	5082
75	4	365LP	255	1862	2006	2902	3046	602*	4246	913*	6340
75	6	405LP	310	2100	2254	3290	3444	676*	4829	1033*	7226
100	2	405LP	230	1443	1580	2269	2406	474*	3336	721*	4998
100	4	405LP	303	1775	1937	2814	2976	581*	4159	892*	6253
100	6	444LP	353	1926	2174	3116	3364	652*	4655	1009*	7052
125	4	444LP	347	1630	1871	2670	2911	561*	4014	873*	6108
125	6	445LP	455	1755	2064	2946	3254	619*	4485	976*	6882
150	4	445LP	417	1518	1795	2558	2835	539*	3902	850*	5996
150	6	447LP	529	1605	1970	2795	3161	591*	4334	948*	6731
200	4	447LP	524	1321	1664	2361	2703	499*	3705	810*	5799
200	6	449LP	673	1324	1795	2515	2985	539*	4053	895*	6451
250	4	449LP	638	1109	1531	2149	2571	459*	3493	771*	5587
250	6	449LP	679	1298	1714	2488	2904	514*	4027	871*	6424

*Only for momentary thrust

Table 6-2



Technical Notes

Bearings and Lubrication (continued)

Bearing Temperature Protection

Bearing RTDs, **A51**, included temperature monitoring on both the drive end and non-drive end bearing. The bearing housing is drilled and tapped for the temperature probe to rest on the outer race of the bearing with the leads in a terminal head on each end (Fig. 6-1). This allows for independent temperature monitoring for each bearing. DP200 HPS motors will include provisions for bearing RTDs as standard. The installation of the RTDs, **A50**, can be added as a modification on this product.

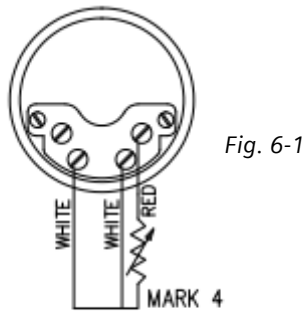
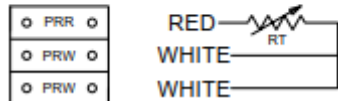

Fig. 6-1



Overhung Load/Belted Considerations

Siemens recommends a roller bearing, **L65**, on the DE for overhung load applications. Roller bearing on DE is standard on SD661 product line and on select 440 frame and up as noted in Table 6-1.

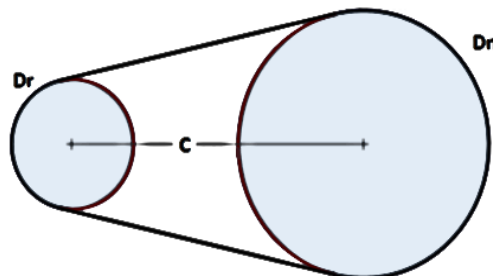
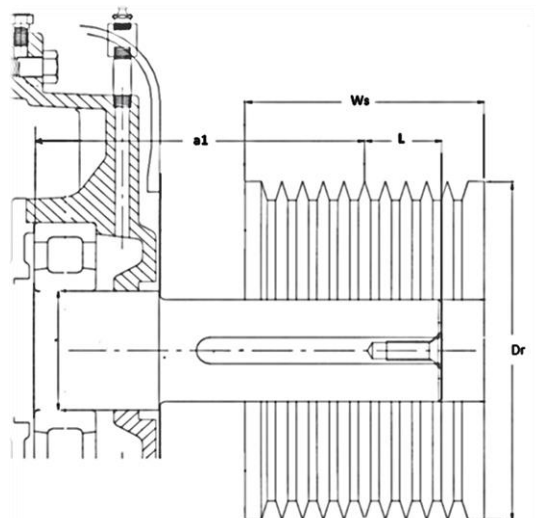

Fig. 6-2

requested through the Siemens LOW VOLTAGE MOTOR Quotation Team. Minimum criteria for belting evaluation is listed below and cannot be properly evaluated without this data.

- Operating Application Horsepower (Can be less than the rated motor HP)
- Operating RPM
- Frame size of selected motor
- Dr = Motor Sheave Diameter (Must be within Table 6-3)
- Dn = Driven Sheave Diameter
- Number of belts
- Type of Belts (e.g. 3V, 5V, 8V, A, B, C, etc.)
- C = Distance between sheaves (center to center)
- L = Distance from center of motor sheave to end of shaft
- Orientation of motor (Horizontal/Vertical shaft up/Vertical shaft down)
- Ws = Face width of motor sheave

Engineering on request. The belting form can be



Technical Notes

Bearings and Lubrication (continued)

Recommended Sheave Diameters for V-belts					
Frame	HP Synchronous RPM			Standard V Minimum Diameter (in.)	Narrow V Minimum Diameter (in.)
	1800	1200	900		
364T	60	--	--	7.4	7.4
365T	75	--	--	9	8.6
404T	--	60	--	9	8
404T	--	--	50	9	8.4
405T	100	--	--	10	8.6
405T	--	75	60	10	10
444T	--	100	--	11.8	10
444T	--	--	75	13	9.5
444T	125	--	--	12	10.5
445T	--	--	100	15	12
445T	--	125	--	15.2	12.4
445T	150	--	--	13.2	10.5
447T	--	150	--	16.1	11.6
447T	--	--	150	24.7	14.6
447T	200	--	--	15.8	13.2
449T	--	200	--	25	14.6
449T	--	--	200	--	18
449T	250	--	--	18.4	13
449T	--	250	--	--	18.2
S449LS	--	--	250	--	19.8
449T	300	--	--	24.8	15.4
S449LS	--	300	--	--	18.4
S449LS	350	--	--	--	15.8
S449LS	--	350	--	--	21
S449LS	400	--	--	--	18

- Narrow V Example: 3V, 5V, 8V.
- Standard V Example: A, B, C, D section
- Do not exceed belt service factor of 1.6.
- Maximum speed reduction of 5:1
- Shaft center distance approximately equal to diameter of largest sheave
- The motor sheave should be located as close as possible to the bearing (1/2" from shaft shoulder).
- The center of the belt system should never extend beyond the end of the motor shaft.

Table 6-3

VSD Application Considerations for bearings

Shaft currents caused by VSD supply can cause damage to bearings that can result in bearing failure. The shaft currents tend to increase as the frame size increases. Siemens recommends the use of an insulated bearing on the NDE of frames 400 and larger to reduce the risk of the shaft current passing through the bearing.

Insulated Bearings, **L66** and **L67**, use a non-conductive insulating sleeve inserted into the bearing housing. This option is effective in reducing the shaft currents, and uses sealed bearings making the bearings non-regreasable.

Hybrid Ceramic Bearings, **L69**, **L70** and **L71**, are a direct replacement for the standard bearing size and are fully regreasable. They utilize ceramic balls to eliminate the currents from passing through the bearings.

SKF INSOCOAT Bearings, **L61**, **L64**, are a direct replacement for the standard bearing size and are fully regreasable. An insulated coating on the outer race of the bearing is used to reduce the risk of the currents passing through the bearing.

See Shafts and Seals for additional options to reduce bearing damage due to shaft currents.



Technical Notes

Shafts and Seals

	1LE2	1MB2	1PC2	1LE6	1PC6 HPS	Codes	Description
Short Codes	✓	✓	✓	✓	✓	K41	Keyless Shaft
	✓	-	-	✓	✓	L29	Shaft Grounding Brush
	✓	✓	✓	--	--	L76	Shaft Slinger & O Ring
	✓	✓	✓	✓	✓	L79	INPRO/SEAL DE
	✓	✓	✓	✓	✓	L80	INPRO/SEAL NDE
	✓	✓	✓	✓	✓	L81	INPRO/SEAL Both Ends
	✓	✓	✓	--	--	L84	Brass Seal
	✓	--	✓	✓	✓	L86	INPRO/SEAL MGS Shaft Grounding - DE
	✓	✓	✓	■	■	L87	ORION Labrinth Copper Seal – DE
	✓	✓	✓	✓	✓	L88	ORION Labrinth Copper Seal – NDE
	✓	✓	✓	--	--	L89	ORION Labrinth Copper Seal - Both Ends
	✓	--	--	--	--	M42	Shaft Ring Brush (Steel) - NDE (AEGIS)
	✓	✓	--	--	--	M52	NEMA Std Long Shaft - NDE
	✓	✓	--	--	--	M53	NEMA Std Short Shaft - NDE
	✓	✓	✓	✓	✓	M57	(C4140) Carbon Steel Shaft
	✓	✓	✓	✓	✓	Y50	Special Shaft on Drive End
✓	✓	✓	✓	✓	Y51	Special Shaft on Non Drive End	

Shafts

The standard shaft material will be C1045 or C4140 as noted in Table 7-1. C4140 shaft material is available as a custom option, **M57**, on frames with C-1045 as standard. Siemens NEMA motors are designed with the shaft dimensions and tolerances to meet the standards of NEMA MG-1 single shaft extension. Any exceptions will be noted on the motor drawings.

Motors can be custom built with a double shaft extension with NDE shaft according to NEMA MG-1. This can be offered as either long shaft, **M52**, or short shaft, **M53**. See Table 7-2 for reference.

Frame	Standard Shaft Material
140-449	C-1045
S449	C-4140
500 (2 Pole)	C-4140
500 (4 & 6 Pole)	C-1045

Table 7-1



Technical Notes

Shafts and Seals (continued)

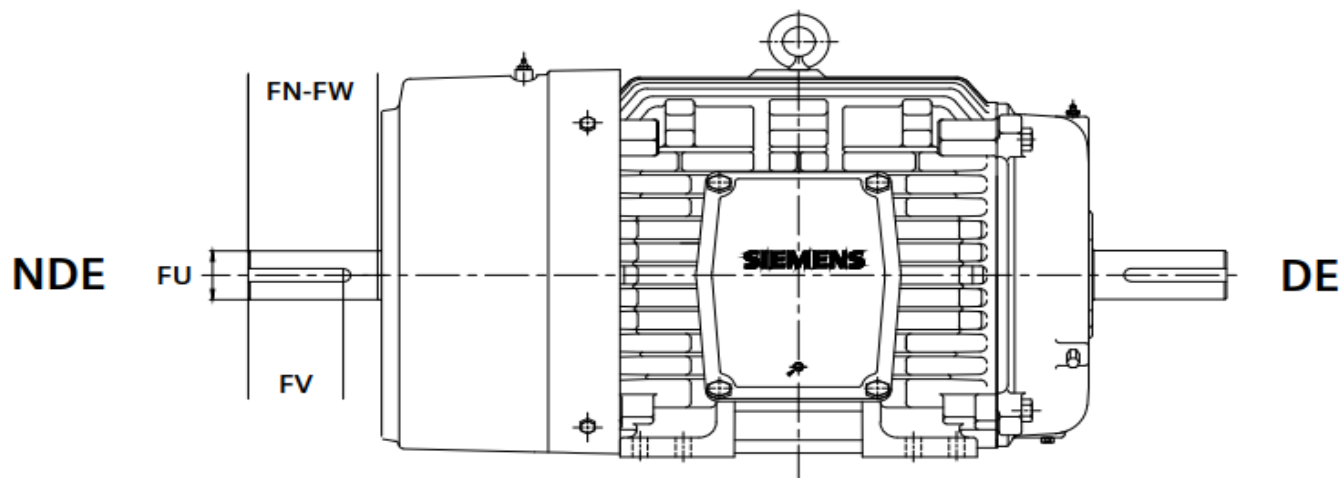

Frame	FU	Key	Order Code = M53			Order Code = M52		
			NEMA Standard Short Shaft			NEMA Standard Long Shaft		
			FN-FW	FV	Key Length	FN-FW	FV	Key Length
143-145T	0.625	0.188	--	--	--	1.62	1.38	0.91
182-184T	0.875	0.188	--	--	--	2.25	2	1.41
213-215T	1.125	0.25	--	--	--	2.75	2.5	1.75
254-256T	1.375	0.312	--	--	--	3.37	3.12	2.37
284-286T	1.625	0.375	3.75	3	1.87	4	3.75	2.87
324-326T	1.875	0.5	0.375	3.5	2	4.62	4.37	3.25
364-365T	1.875	0.5	3.75	3.5	2	4.62	4.37	3.25
404-405T	2.125	0.5	4.25	4	2.75	5.25	5	3.87
444-449T	2.375	0.625	4.75	4.5	3	5.87	5.62	4.25

Table 7-2

Motors can be custom built with a special shaft extension on DE, **Y50**, or NDE, **Y51**. These options can be used for special dimensions or special shaft features (ex: drill and tap, threaded shaft, special keyway, etc.) and must be quoted by the Siemens LOW VOLTAGE MOTOR Quotation Team.

Keyless DE shaft extension, **K41**, is available as a custom feature. All other shaft dimensions will remain in accordance with NEMA MG-1 (unless otherwise noted in drawing).

Seals

Shaft seals are used to protect the bearings from liquid and dust contaminants that lead to premature bearing failure. NEMA motor are

equipped with v-ring shaft seals as standard on all General Purpose motors and severe duty motors unless otherwise noted. The v-ring shaft seal provides protection to meet IP55.

Labyrinth Seals (Inpro Seals, **L79**, **L80**, and **L81**) (Orion Seals, **L87**, **L88**, **L89**), are shaft rotating seals that provide extra ingress protection from water and dust while the motor is in operation. Motors that are noted to meet IEEE 841 or when IEEE 841 features, **K10**, will include labyrinth seals on both ends. The SD200 motor line has a labyrinth seal on the DE as standard.

Shaft slinger and O-ring, **L76**, is used in shaft up applications to help reduce liquid from running down the shaft and settling in the seal area.

Technical Notes

Shafts and Seals (continued)

VSD Application Considerations for Shaft Grounding

Shaft grounding can reduce the risk of shaft currents from passing through the bearings.

This allows the current generated in the shaft to flow harmlessly to the frame and ultimately to ground bypassing the bearings in the process. Shaft grounding options are considered sparking devices and cannot be used in hazardous areas. When selected for SD products, the Division 2 information will be removed from the nameplate.

SGS™ MOTOR GROUNDING BRUSH & RING SYSTEMS, **L29**, mounts on the fan housing with a carbon brush that makes contact with the motor shaft. The carbon brush is rated at 100,000 hours before being changed.

Bearing Isolator + grounding brush, (INPRO Seal, **L86**), uses the labyrinth sealing protection of an Inpro Seal combined with shaft grounding brushes that rest on the shaft behind the sealing mechanism. The brushes reduce the shaft currents from passing through the bearings while the seal reduces contamination build up on the grounding brushes and in the bearing.

AEgis grounding brush, **M42**, can be added to the NDE on GP100 motors.



Frame

	1LE2	1MB2	1PC2	1LE6	1PC6 HPS	Codes	Description
Short Codes	✓	✓	■	✓	✓	K33	Drip Cover
	✓	✓	■	-	-	K34	Lifting Hooks (No Drip Cover)
	✓	✓	-	■	■	K38	Provisions for Dowel Holes
	✓	✓	✓	✓	✓	K70	Rotation Arrow Bidirectional
	✓	✓	✓	✓	✓	K71	Rotation Arrow Clockwise (from NDE)
	✓	✓	✓	✓	✓	K72	Rotation Arrow Counterclockwise (from NDE)
	✓	■	■	■	■	L20	Lifting Eyebolt
	✓	-	✓	✓	✓	L22	Stainless Steel Hardware (Includes T Drain SS)
	✓	✓	✓	✓	✓	L27	Ground Bolts - Qty 2
	✓	-	✓	✓	✓	L45	SS T-Slot Breather Drain
	✓	✓	✓	✓	✓	L46	CROUSE HINDS UL Approved Breather Drain
	-	✓	-	-	-	L90	IP66 Ingress Protection
	✓	-	-	-	-	M09	Aluminum Fan
	✓	-	✓	-	-	M10	Bronze Fan (S440 - Std)
✓	✓	-	-	-	M28	Stainless Steel Eyebolt	
✓	✓	-	■	■	M39	Vertical Jacking Provisions	

Feet

Motors with cast iron frame will have cast in feet as standard.

Provisions for dowel holes, **K38**, provides a hole drilled at an angle in each of the motor feet. The holes will be used as a guide for drilling the mounting plate for the addition of the dowel once the motor is aligned to the driven equipment. Dowels can be used to pinpoint the alignment of the motor to the driven equipment when the motor is taken out for service. Provisions for dowels is a standard feature on the SD200 500 frame motors.

Motors will be delivered as standard with dual/tri drilled mounting holes in the feet for increased flexibility in mounting.

Provisions for vertical jacking, **M39**, provides threads in the non-mounting holes on the feet in order that a bolt may be added for leveling of the motor during installation. Jacking provisions are required on motors that exceed 500 lbs to meet API610 requirements for horizontal pump applications.

The GP100A aluminum frame includes bolt on feet, 140-250 frames, for flexibility with in the field changes.

Lifting

Horizontal cast iron motors up to S449 will be supplied with an eye bolt located in the center line of the center of gravity on the motor frame. 500 frame motors are provided with two lifting eye bolts located at opposite corners of the motor frame. They will also include alternate locations on the motor where the eye bolts can be relocated and Vertical mounted 500 frame motors, as defined in position 14 of the MLFB, will include swivel lifting hooks to provide safer movement of the motor.

Lifting Hooks, **K34**, are closed hooks used for vertical lifting and will be supplied with one on each side of the motor. Lifting hooks are standard when mentioned in the mounting description for Position 14 of the MLFB and on the LP/HP motors. Lifting hooks are only available on round frame motors.

Technical Notes

Frame (continued)

Fan and Fan Cover

The standard bidirectional cooling fan is non-sparking polypropylene design, unless otherwise noted. Directional fans will have polypropylene blades with metallic mounting. Bronze fans, **M10**, are non-sparking and may be used on bi-directional motors. Aluminum fans, **M09**, may only be used on safe area motors and do not comply with IEEE 841 standards.

NEMA motors are supplied as either bi-directional or clockwise as standard (directional motors will be noted in motor selection section) as viewed from Non-Drive End (NDE). The new SD200 frame size 500 will be bidirectional in all ratings and speeds.

Rotation arrows, **K70**, **K71**, **K72**, can be added to the fan housing for clarity. Motors supplied as unidirectional will have a rotational arrow as standard. Option **K72** can be used to achieve counter clockwise rotation on a motor that has clockwise as standard (this will make the motor MOD or Custom).

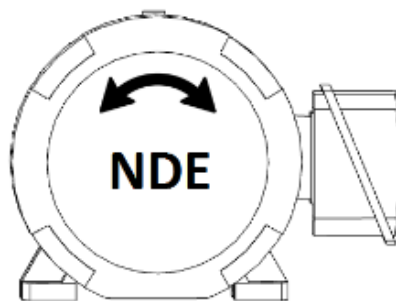

Drip cover, **K33**, can be added to the fan cover of motors used in vertical shaft down applications in order to protect the motor from water or liquids from falling directly into the fan housing. Drip Cover is standard when mentioned in the mounting description for Position 14 of the MLFB and on the LP/HP motors. See Table 8-1 for drip cover dimensions.

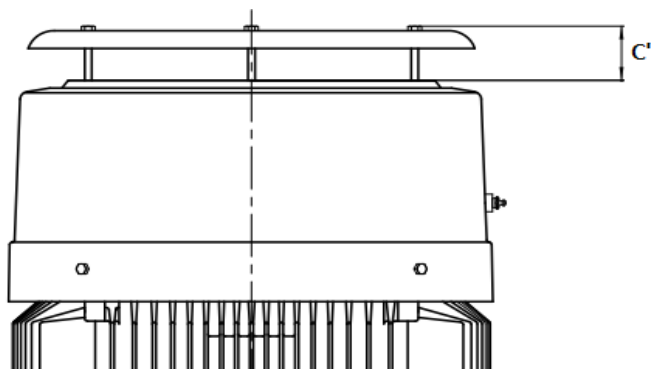

Drip Cover Dimensions	
Frame	C'
140	1.54
180	1.7
210	1.49
250	2.15
280	2.15
320	2.15
360	2.15
400	2.15
440	2.68

Table 8-1



Technical Notes

Frame (continued)

Hardware

Standard hardware is grade 5 zinc plated corrosion resistant hardware. Stainless steel hardware, **L22**, includes all external nuts and bolts as well as the T-Drain. Stainless steel eyebolt, **M28**, is not included with **L22**. Stainless steel hardware is included with options for low ambient temperature, **B27**, **B28**, **B29**, and is not available on XP motors. Stainless steel T-drain, **L45**, will include only the drain as stainless steel.

All NEMA motors will include tapped holes on each side of the frame near the feet for frame grounding. Bronze ground bolts, **L27**, can be added for additional provisions (adds two bolts).

Various types of drains are used based on the motor types (see motor type introduction for clarity). Drain plugs require the user to unscrew the plug to allow the moisture to escape during times of idle use. T-slot drains allow for moisture to drain from the motor freely without user intervention. Crouse Hinds drains, **L46**, are UL approved drains that can be added on frames 280 and larger. The Crouse Hinds drain is standard on XP motors in frame 280 and larger.

Ingress Protection

The ingress protection (IP) rating is the protection grade against water and dust. The IP rating on the nameplate applies to completed motor, including shaft seals, bearing housing fits, and terminal box. The first number designation in the IP rating, IP_*, relates to the protection against water. The second number designation in the IP rating, IP*__, relates to the protection against dust. GP100 motors will have a standard IP54 rating. Severe Duty and Definite purpose motors will have a standard IP55 rating that can be increased up to IP66 with a special quote from the Siemens LOW VOLTAGE MOTOR Quotation Team. Explosion proof motors have a standard IP65 rating that can be increased to IP66 with option, **L90**.

Technical Notes

Rating Plates and Tagging

	1LE2	1MB2	1PC2	1LE6	1PC6 HPS	Codes	Description
Short Codes	✓	✓	✓	✓	✓	M21	Additional Nameplate (Without Logos)
	✓	--	✓	✓	✓	M22	Class I, Division 2 Tag
	✓	✓	✓	✓	✓	M23	Space Heaters Caution Plate
	✓	✓	✓	✓	✓	M24	Lubrication Plate
	✓	✓	✓	--	--	M25	Class II, Division 2
	--	✓	--	--	--	M32	Class II, Group E Hazardous Area
	✓	✓	✓	✓	✓	Y80	Derate-Altitude-Ambient (Nameplate Change)
	✓	✓	✓	✓	✓	Y82	Auxiliary n/p Max. 40 Characters (Aux Tag)

Main Nameplate

Serial Number

Part Number

Bearing Information

VSD Information

Grease Type

Compliance Logos

Electrical Characteristics

Area Classification/Temp Code

HP	kW	R.P.M	V	A	Hz	S.F.	S.F.A	NOM.%	MIN.%
75	55.95	1780	460	85.0	60	1.15	98.0	95.4	95.0

280 – S449 Frame

50HZ Data

HP	R.P.M	V	A	Hz	S.F.	S.F.A	kW	NOM.%	MIN.%
5	1755	230/460	13.0/6.5	60	1.15	15.0/7.5	3.73	89.5	87.5
	1455	200/400	14.5/7.2	50	1	--		--	--

140 – 250 Frame

HP	kW	R.P.M	V	A	Hz	S.F.	S.F.A	NOM.%	MIN.%
500	373	1790	460	570	60	1.15	655	96.7	96.5

500 Frame

Figure 9-1



Technical Notes

Rating Plates and Tagging (continued)

Siemens NEMA Nameplates will include:

- Motor Type
- Certification logos (Where applicable)
 - No ANCE Logo on XP motors
- Part Number (Note: -Z = Custom or Modified)
- Frame
- Cooling Type
- NEMA Design
- Ingress Protection rating
- Bearing information
- Serial Number (sales order number if custom or modified)
- Duty cycle
- Insulation and temp rise Class
- Max ambient temperature (min ambient temperature if below -29C)
- Nominal and Minimum Efficiency
- 60HZ Rating Data: HP, equivalent KW, RPM, Volts, Hz, full load amps, Service Factor, Service Factor Amps
- 50HZ Data (Where applicable)
 - 140-250 frame SD100, GP100, and GP100A
 - All frames for HP100, LP100 and
- XP100 ID1
- VSD turndown information (See VSD Operation Section)
- Connection diagram
- Type of grease (only with re-greasable bearings)
- Hazardous area classification with temp code (where applicable)
- Location of manufacture
- Standards will be added were applicable
 - IEEE841, API661, API610, Etc..

A rating plate similar to the original nameplate, **M21**, can be supplied with the motor attached to the eyebolt during shipment. The **M21** plate can only be supplied without the logos on the plate.

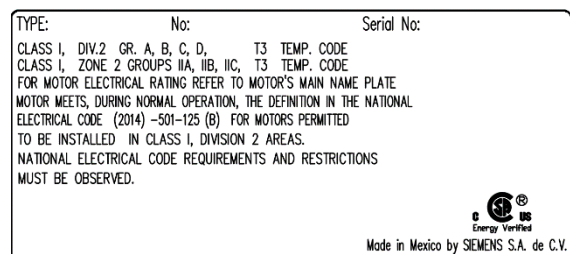

Fig. 9-2

All Severe Duty and Definite Purpose motors will be tagged as Class I, Division 2 as standard. Separate Division 2 tag, **M22**, can be supplied that provides additional information (see example Figure 9-2).

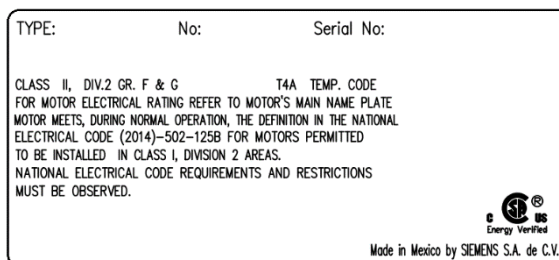

Fig. 9-3

Motors can be supplied suitable for Class II, Division 2, **M25**, for areas with dust related hazards. The motors will be equipped with additional features and tagging (see example Figure 9-3).

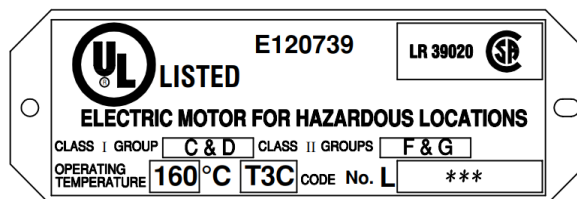

Fig. 9-4

Explosion proof motors will have a separate UL tag with the area classification defined as per Figure 9-4. Class II, Division 1, Group E hazardous area, **M32**, can be added on the XP100 motor line as a build.

Technical Notes

Rating Plates and Tagging (continued)

Motor main nameplate may be modified, **Y80**, for de-rate, re-rate, deviated altitude, deviated ambient, or information added to the main nameplate. Information must be consistent with guidelines listed in catalog for de-rate or re-rate and within the limitations set in the ambient and altitude section (unless custom quotation is referenced).

Note: Siemens reserves the right to reject/ hold an order based on inconsistent information or the lack of information provided for option Y80. When additional information is requested on the nameplate, it may result in standard information being displaced or removed due to space restrictions.

Auxiliary Plates

An auxiliary tag, **Y82**, may be provided separate from motor nameplate. This tag can be used for free text provided by customer in PO. This is often used for customer tagging or customer instructions. The tag has a character limit of 40 which includes spaces and special characters. *Note: Siemens will not be held accountable for free text provided by customer that is provided in the PO that proves to be inconsistent with the motor design (unless specified in a Siemens custom quotation, Figure 9-5).*

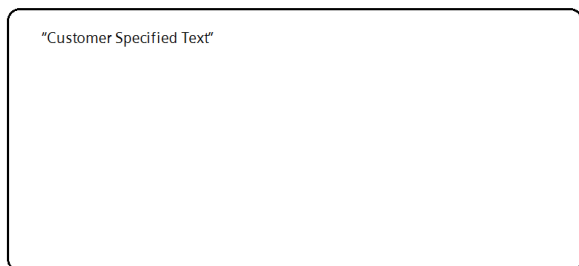

Fig. 9-5

A space heater caution plate, **M23**, may be added when space heaters are included on the order (see example Figure 9-6).

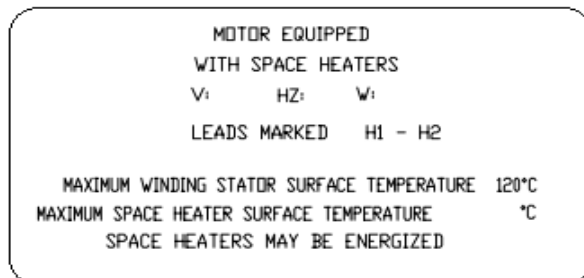

Fig. 9-6

A separate lubrication plate, **M24**, may be added for additional details on motor lubrication (see example Figure 9-7).

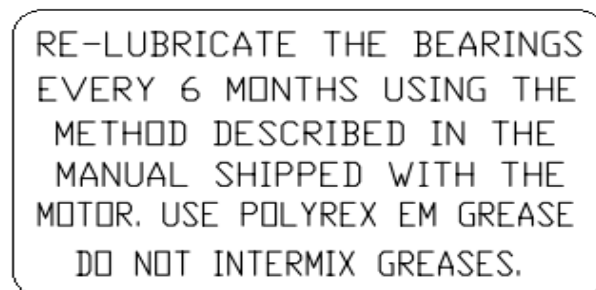

Fig. 9-7



Ambient and Altitude

	1LE2	1MB2	1PC2	1LE6	1PC6 HPS	Codes	Description
Short Codes	✓	--	✓	✓	✓	B27	+40C to -30C Ambient Temp
	✓	--	✓	✓	✓	B28	+40C to -40C Ambient Temp
	✓	--	✓	✓	✓	B29	+40C to -50C Ambient Temp

Standard Ambient and Altitude

General Purpose and Severe Duty NEMA motors are suitable for operation at an altitude up to 3300 feet (1000 meters) above sea level with an ambient temperature range of -25C to 40C with 1.15 service factor as standard.

Explosion proof motors up to 447 frame will have a standard maximum ambient temperature of 55C with 1.15SF. The 449 frame can be offered with 55C with **MLFB position 15 "T"** (see Winding Protection) and with 1.0 SF. Explosion proof Division 1 motors cannot be offered at an ambient below -25C.

Increased Ambient or Altitude

Altitude can be adjusted up to 9900 feet or Ambient can be adjusted up to 55C with a reduction in service factor to 1.0 using **Y80** option code.

Altitude may also be increased with reduction in ambient per Figure 10-1.

For altitude above 9900 feet or ambient above 55C please contact the Siemens LOW VOLTAGE MOTOR quotation team.

Maximum Altitude	Maximum Ambient
3300 ft (1000m)	40°C (104°F)
6600 ft (2000m)	30°C (56°F)
9900 ft (3000m)	20°C (68°F)

Table 10-1

Low Ambient Conditions

Ambient temperatures below -25C can cause standard grease to become ineffective and some standard metals to become brittle leading to motor failure or damage. Features for low ambient conditions, **B27** for down to -30C, **B28** for down to -40C, **B29** for down to -50C, include special grease, external hardware, shaft material, lead material, and seals for suitability for the low temperatures.

Technical Notes

Mechanical Design & Accessories

	1LE2	1MB2	1PC2	1LE6	1PC6 HPS	Codes	Description
Short Codes	✓	--	--	--	--	A66	ROBERT SHAW Vibrator Detector Model 366 - D8 120VAC
	✓	✓	✓	✓	■	A67	Provision for Vibration Sensors (PMC/BETA)
	✓	--	✓	--	--	G05	DYNAPAR Encoder HS35R 1024 PPR
	✓	--	✓	--	--	G06	C-Face Mounted SLIM Tach Encoder
	✓	--	--	--	--	H04	C-Face Mounted Brake
	✓	--	✓	✓	✓	K10	IEEE 841 Features
	--	--	✓	--	--	K20	API 610
	✓	✓	--	--	--	M05	Larger Fan
	✓	--	--	--	--	M08	Separately Driven Fan
	--	--	✓	--	--	M18	Non-Reverse Ratchet
	✓	✓	✓	--	--	M69	Precision
	✓	✓	✓	--	--	M70	Extra Precision Balance

Standards

IEEE 841 Features, **K10**, adds the applicable features of IEEE 841 to the motor. VSS motors and motors over 500 HP fall outside the scope of IEEE 841 and will be nameplated with "IEEE 841 Features."

API610, **K20**, provides the stringent guideline of API610 pumps to the LP100 motor line with high thrust. API610 is not available with extra high thrust, **K21**. See Bearings and Lubrication section for additional information.

Balance

All SIMOTICS motors are dynamically balanced to commercial limits measure in accordance with NEMA MG1-12.06. Precision and Extra Precision balance, **M69**, **M70**, provides more stringent balancing guidelines per Table 11-1.

Balance	NEMA	Precision Balance		Extra Precision Balance		
		Frames	140-320	360-449	140-256	280-320
RPM						
Maximum amplitude, inches, peak to peak (mils P/P)						
0 - 999	2.5	0.5	0.75	0.2	0.3	0.4
1000 - 1999	2.0	0.5	0.75	0.2	0.3	0.4
2000 - 2999	1.5	0.5	0.75	0.2	0.3	0.4
3000 - 4000	1.0	0.5	0.75	0.2	0.3	0.4
Velocity, inches, inches/seconds (in/sec)						
0 - 999	0.1308	0.0262	0.0392	0.105	0.0157	0.0209
1000 - 1999	0.2093	0.0523	0.0785	0.0209	0.0314	0.0419
2000 - 2999	0.2355	0.0785	0.1178	0.0314	0.0471	0.0628
3000 - 4000	0.2094	0.1047	0.1571	0.0419	0.0628	0.0838

Table 11-1



Technical Notes

Mechanical Design & Accessories (continued)

Vibration Monitoring

ROBERT SHAW Malfunction vibration detectors, **A66**, are a single point vibration monitoring switch. This is designed to trip and shut down the motor in the event of excessive vibration.

Provisions for vibration sensors, **A67**, will provide 1/4"–28 UNF drilled and tapped holes on each bearing housing when selected with no additional instruction. This option can also be adapted to the required drill and tap required for a customer specified vibration sensor with quote from LOW VOLTAGE MOTOR quotation team. SD200 and DP200 motor lines in 500 frame will have provisions for vibration sensors as a standard feature. The sensor is not included with this option and must be supplied by the customer.

Accessories

Encoders

DYNAPAR HS35R, **G05**, is a hollow shaft rotary pulse 1024 PPR encoder with single output. It is mounted on an NDE shaft extension that extends beyond the fan housing. It is held in place with an arm that is attached to the fan housing.

DYNAPAR SLIM Tach ST56 for 140-250 frames or ST85 for 280-5449, **G06**, is a c-face mounted 1024 PPR encoder with single output.

Technical Notes

Mechanical Design & Accessories (continued)

Brake

C-Face Mounted Brake, **H04**, will be a Stearns brake, rated IP55, rigidly mounted to the NDE of the motor with a special designed bearings housing with C-face for mounting the brake.

Brakes will be supplied with rated supply voltage equivalent to the motor voltage. See table 11-2 for basic brake data.

Data and Dimensions for Added Brake (H04)									
Motor Rating				Brake Details					
2 Pole	4 Pole	6 Pole	8 Pole	IP##	lb-ft	Type	C-C'	X	Y
HP	HP	HP	HP						
1-1.5	1	--	--	IP55	3	56,000	4.06"	0.61"	2.94"
3	1.5-2	1	--	IP55	6	56,000	4.06"	0.61"	2.94"
5	3	1.5	--	IP55	10	56,000	4.51"	0.61"	2.94"
--	--	--	1	IP55	10	56,000	4.51"	0.61"	2.94"
7.5	5	2	1.5	IP55	15	56,000	4.51"	0.61"	2.94"
--	--	3	2	IP55	20	56,000	4.51"	0.61"	2.94"
10	--	--	3	IP55	25	56,000	4.51"	0.61"	2.94"
15	7.5	5	--	IP55	35	87,000	7.38"	1.81"	4.69"
20-25	10	7.5	5	IP55	50	87,000	7.88"	2.31"	4.69"
30	15	10	7.5	IP55	75	87,000	8.12"	2.5"	4.69"
40	20-25	15	10	IP55	105	87,000	8.62"	3"	4.69"
--	30	20	15	IP55	125	87,000	8.56"	2.81"	4.69"
--	40	25	20	IP54	175	81,000	11.45"	2.75"	6"
--	50	30	25	IP54	230	81,000	11.95"	3.25"	6"
--	60-75	40-50	30-40	IP54	330	82,000	12.76"	4.5"	6"
--	100	60	50	IP54	440	82,000	14.01"	5.75"	6"
--	125	75	60	IP54	500	86,000	13.57"	5.38"	6"
--	150	--	75	IP54	750	86,000	13.57"	5.38"	6"
--	200-250	100-125	100	IP54	1000	86,000	13.57"	5.38"	6"

Table 11-2



Technical Notes

Mechanical Design & Accessories (continued)

Additional Cooling for VSD Applications

Larger Fan, **M05**, can be added on 4 pole motors in frames 360-440 to provide additional cooling and extended speed range for constant torque. See [Table 15-1](#) and [15-2](#) for new range. The motor will be labeled as VSD only and the NEMA Premium logos will be removed from the nameplate.

External Force cooling, **M08**, can be added to

severe duty motors for increased turndown on VSD

applications. The blower motor voltage will follow the voltage of the drive motor. The addition of the blower will increase the constant torque turndown to 1000:1. Class H insulation, **C00**, and Spike Resistant Wire, **C03**, and insulated bearing for frame 360 and above is also recommended for 1000:1 CT applications. Table 11-3 shows the added dimensions for option **M08**.

Added Dimensions for Blower Cooled (M08)		
		
Frame	C'	C
143-145T	--	--
182-184T	--	--
213-215T	--	--
254-256T	30.58	40.17
284-286T	34.21	43.8
324-326T	37.93	47.52
364-365T	40.44	50.04)
404-405T	43.53	53.12
444-449T	49.76	59.35

Table 11-3

Others

Non-Reverse Ratchet (NRR), **M18**, prevents the opposite rotation of the shaft on the LP100 motor line. NRR is only available for standard clockwise

rotation. This device is not suitable for hazardous locations and the standard Division 2 information will be removed from the nameplate.

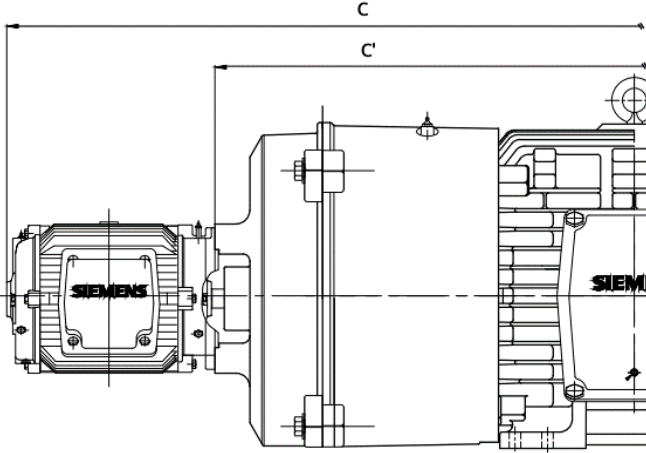
Technical Notes

Paint and Packaging

	1LE2	1MB2	1PC2	1LE6	1PC6 HPS	Codes	Description
Short Codes	✓	✓	✓	✓	✓	B09	Export Packaging Sea freight - Siemens Standard
	✓	✓	✓	✓	✓	B10	Export Packaging Special Export Box
	✓	✓	✓	✓	✓	N01	2 Part Epoxy (Industrial-Coastal Low Salt)
	✓	✓	✓	✓	✓	N02	3 Part Epoxy (Industrial-Coastal Moderate Salt)
	✓	✓	✓	✓	✓	N03	Primer Only
	✓	✓	✓	✓	✓	N05	3 Part Epoxy (Coastal-Offshore High Salt)
	✓	✓	✓	✓	✓	Y60	Special color (Provide RAL#)

Packaging

Motors in frames 140-250 frame will be packaged in a reinforced cardboard box with the motor bolted to a wooded base. Frames 280 and larger will be bolted to an open wood pallet and wrapped in plastic to protect the finish.

Export packing, **B09**, the motor will be secured into a fully enclosed wood crate with shock and tilt indicators. Special packing, **B10**, can be customer defined and must be offered by the factory through the Siemens LOW VOLTAGE MOTOR quotation team.

Paint

NEMA motors as standard are protected against corrosion (C2 category) and external influences with high-quality coatings based on (Alkyd Modified + Epoxy) with final standard color RAL-7030. Special colors, **Y60**, are available as RAL color only and must be specified at time of order. RAL color website: <http://www.ralcolor.com/>

If a higher corrosive class is required, a special paint system must be included. See table 12-1 for details.



Technical Notes

Paint and Packaging (continued)

Siemens Paint Systems for LV NEMA Motors					
	Standard Siemens Paint System	Special Paint Systems Offered by Siemens			
	Standard Alkyed + Epoxy	2 Part Epoxy (N01)	3 Part Epoxy (N02)	Prime Only (N03)	3 Part Epoxy Paint (Coastal-Offshore High Salt) (N05)
Priming of Internal and External Surfaces					
Type	Modified Alkyd	Epoxy Polyamide	Zinc Inorganic	Modified Alkyd	Zinc Inorganic
Color	Blue	Red Iron Oxide	Metallic Gray	Blue	Metallic Gray
Sheen	Flat	Flat	Flat	Flat	Flat
Dry Film Thickness	2-3 mils.	2.0 - 3.0 mils	3.0 mils	2 mils	3.0 mils
Intermediate Coat of External Surfaces					
Type	N/A	N/A	Epoxy	N/A	Epoxy
Color	N/A	N/A	White	N/A	White
Sheen	N/A	N/A	Flat	N/A	Flat
Dry Film Thickness	N/A	N/A	3.0 mils	N/A	5.0 mils
Top Coat on External Surfaces					
Type	PROMETAL E-26-B (Epoxy)	Epoxy Polyamide	Modified Polyurethane	N/A	Modified Polyurethane
Color	RAL 7030 Stone Gray	RAL 7030 Stone Gray	RAL 7030 Stone Gray	N/A	RAL 7030 Stone Gray
Sheen	Flat	Semi Gloss	Gloss	N/A	Gloss
Dry Film Thickness	3-6 mils.	2.0 - 3.0 mils	2.0 - 3.0 mils	N/A	5 - 6 mils
Total Film Thickness	5-9 mils	4.0 - 6.0 mils	8.0 - 10.0 mils	2 mils	13 - 17 mils
Salt Spray Resistance (Hours)	400	1500	2000		2000+
Corrosivity Category	C2	C3	C4		C5I & C5M

Table 12-1

Motors can be provided with primer only, **N03**, to allow the customer to apply their own final paint in the field.

The 2 Parts Epoxy paint system, **N01**, offers excellent resistance to the corrosive action of chemical agents, prolonged weathering and to the action of direct sunlight.

The 3 Parts Epoxy paint system, **N02**, is an organic base of Epoxy Zinc, provides a high resistance to humid environments (saline or no-saline) but not for offshore ocean climate, excellent inhibitory capacity to corrosion, excellent resistance to abrasion, high temperatures (ambient

temperatures > 59°C) and to the most of industrial solvents (splashes). This Paint System is recommended to apply in high relative humidity environments (>60%).

The 3 parts epoxy (Coastal-Offshore High Salt) paint system, **N05**, is recommended for offshore installation, provides good chemical resistance to splash/spillage, fumes and immersion in neutral, fresh and salt water. Effectively protects the motor from corrosion resulting from industrial and marine exposures as it is safeguarding the environment.



Technical Notes

Documentation

	1LE2	1MB2	1PC2	1LE6	1PC6 HPS	Codes	Description
Short Codes	✓	✓	✓	✓	✓	D05	Documentation in Spanish
	✓	✓	✓	✓	✓	F00	Certificate of Compliance
	✓	✓	✓	✓	✓	F03	Standard Performance Curve
	✓	✓	✓	✓	✓	F07	Special Calculated Data
	✓	✓	✓	✓	✓	F40	Stall Time (Thermal Limit Curve)
	✓	✓	✓	✓	✓	F42	Standard Dimension Sheet
	✓	✓	✓	✓	✓	F43	Nonstandard Dimension Sheet
	✓	✓	✓	✓	✓	F44	Conduit Box Dimension Sheet
	✓	✓	✓	✓	✓	F45	Wiring Diagram
	✓	✓	✓	✓	✓	F46	Instruction and Operation Manual
	✓	✓	✓	✓	✓	F47	Renewal Parts
	✓	✓	✓	✓	✓	F49	Performance Data Sheets
✓	✓	✓	✓	✓	F50	Customer Specific Data Sheets	

Siemens offers much of our documentation and certificates for download through our online DT-Configurator tool. This allows the data to be tailored to the motor configuration. Documentation provided through order codes will be provided in Siemens standard electronic format unless otherwise noted. Information that is proprietary to Siemens will not be included in documentation supplied.

Curves

Standard performance curves, **F03**, will include the motor calculated speed torque curve and calculated performance curve (Efficiency, Power Factor, and Amps Over percent of rated horsepower) at rated voltage. This curve is also available for download through the DT-Configurator.

Special calculated data, **F07**, can be used for a variety of special calculations.

- Curves supplied with reduced voltage
- Shaft torsional analysis
- Bearing L10 calculations

Stall Time Curve, **F40**, is a logarithmic curve of current (in present of full load) over time. The curve will be shown for both hot and cold conditions and graphically illustrates the safe stall time.

Drawings

Motor drawings can be provided in either pdf or dxf format as specified in the purchase order. The standard drawing, **F42**, can be used for a standard F1 configuration with no special options. This drawing is also available for download through the DT-Configurator.

The non-standard drawing, **F43**, can be used for motors with mechanical modifications that would add on accessories or change the standard dimensions of the motor.

Conduit box drawing, **F44**, can be used for a standard conduit box drawing.



Technical Notes

Documentation (continued)

Data Sheets

Typical Data sheet, **F49**, will provide an electrical data sheet for the motor ordered in Siemens standard format.

Customer specific data sheet, **F50**, provides the customer with the project data sheet filled out by Siemens engineering. The customer data sheet must be supplied in excel format at the time the purchase order is placed.

Other Documentation

Documentation and nameplates can be provided in Spanish, **D05**. This option will also include NOM on the nameplate.

Certificate of compliance, **F00**, can be issued to certify compliance with ISO standards.

Wiring diagram, **F45**, will provide a pdf copy of the motor wiring diagram for the motor ordered. This document is also available for download through the DT-Configurator.

Instruction and Operation Manual, **F46**, is general instructions for installation, operation and maintenance for NEMA motors. This document is also available for download through the DT-Configurator.

Replacement parts list, **F47**, will provide part numbers and general descriptions for the following spare parts:

- Bearings, Fan, Fan housing, Conduit Box, Bearing housings (flange if applicable), and seals

Technical Notes

Tests

	1LE2	1MB2	1PC2	1LE6	1PC6 HPS	Codes	Description
Short Codes	✓	✓	✓	✓	✓	F10	Routine Test Report
	✓	✓	✓	✓	✓	F12	Routine Test Report (Witnessed)
	✓	✓	✓	✓	✓	F15	Complete Test
	✓	✓	✓	✓	✓	F17	Complete Test (Witnessed)
	✓	✓	✓	✓	✓	F20	Routine Test + Vibration
	✓	✓	✓	✓	✓	F22	Routine Test + Vibration (Witnessed)
	✓	✓	✓	✓	✓	F27	Performance Load Test (Curve Report)
	✓	✓	✓	✓	✓	F30	Noise Test
	✓	✓	✓	✓	✓	F32	Noise Test (Witnessed)
	✓	✓	✓	✓	✓	F36	Routine Test Report of Electrical Duplicate Design
	✓	✓	✓	✓	✓	F37	Type Test Report of Electrical Duplicate Design
--	✓	--	--	--	F90	IEC EX Certification	

Routine Test, F10, F12

Routine test consists of the following items tested in accordance with IEEE standard 112.

- No Load Current
- No Load Speed
- Nominal Current at Locked Rotor
- Winding Resistance
- High Potential
- Bearings/Vibration Check

Routine Test with vibration, F20, F22

Includes all tests from standard routine test with additional records of vibration testing. A hard copy of the Routine Test with vibration is included on all IEEE 841 compliant motors, adding **F20** will get you the test report in electronic format.

Test report of routine test is based on IEEE Std. 112 Form A-1 and includes complete nameplate information.

Electrical Duplicate Routine Test, **F36**, is an electronic copy of a test report of the same electrical design as the motor on order.

Complete Test, F15, F17

Complete test consists of the following items tested in accordance with NEMA and IEEE-112 test standards.

- Full Load Heat Run

- Temperature Rise at F.L.
- Winding Resistance
- Rated F.L. Slip
- No Load Current
- Breakdown Torque
- Locked Rotor Torque-Amps
- High Potential Tests
- Efficiencies @ 100, 75, 50 Percent Load
- Power Factor @ 100, 75, 50 Percent Load

Test report of complete test is based on IEEE Std. Form A-2 and includes complete nameplate information.

Electrical Duplicate Complete Test, **F37**, is an electronic copy of a test report of the same electrical design as the motor on order.

Performance Load Test, F27

Performance Load Tests the motors at select points from 0-125% of the rated load recording speed, torque, current, power factor and efficiency, at rated voltage. Data is curve plotted, on Siemens standard format. Foot mounted motors only.

Noise Test, F30, F32

Motors are tested according to IEEE 85 standard in unloaded condition only. Test report will be provided with Sound Pressure (L_p) and sound power (L_w) in octave bands of 125Hz, 250Hz, 500Hz, 1kHz, 2kHz, 4kHz, and 8kHz.



Technical Notes

VSD Operation

For additional information on options related to VSD operation see sections on Bearings and Lubrication, Shafts and Seals, and Mechanical Design and Accessories

Severe Duty Motors (SD100, SD100IEEE, SD661, SD200, DP200)							
Frame	Poles	Standard		M05 Option	C00+C03+ M08 Options	Temp Codes	
		Constant Torque	Variable Torque	Constant Torque	Constant Torque	Standard Class I, Division 2	M25 option Class II, Division 2
						Temp Code	Temp Code
143T - 145T	2, 4, 6	20:1	20:1	NA	1000:1	T3 (200°C)	T4A (120°C)
	8	4:1	20:1	NA	1000:1	T3 (200°C)	T4A (120°C)
182T - 184T	2, 4, 6	20:1	20:1	NA	1000:1	T3 (200°C)	T4A (120°C)
	8	4:1	20:1	NA	1000:1	T3 (200°C)	T4A (120°C)
213T - 215T	2, 4, 6	20:1	20:1	NA	1000:1	T3 (200°C)	T4A (120°C)
	8	4:1	20:1	NA	1000:1	T3 (200°C)	T4A (120°C)
254T - 256T	2, 4, 6	20:1	20:1	NA	1000:1	T3 (200°C)	T4A (120°C)
	8	4:1	20:1	NA	1000:1	T3 (200°C)	T4A (120°C)
284T - 286T	2, 4, 6	20:1	20:1	NA	1000:1	T3 (200°C)	T4A (120°C)
	8	4:1	20:1	NA	1000:1	T3 (200°C)	T4A (120°C)
324T - 326T	2, 4, 6	20:1	20:1	NA	1000:1	T3 (200°C)	T4A (120°C)
	8	4:1	20:1	NA	1000:1	T3 (200°C)	T4A (120°C)
364T - 365T	2, 4, 6	20:1	20:1	NA	1000:1	T3 (200°C)	T4A (120°C)
	8	4:1	20:1	NA	1000:1	T3 (200°C)	T4A (120°C)
404T - 405T	2, 4, 6	4:1	20:1	10:1	1000:1	T3 (200°C)	T4A (120°C)
	8	4:1	20:1	NA	1000:1	T3 (200°C)	T4A (120°C)
444T - 445T	2, 4, 6	4:1	20:1	10:1	1000:1	T3 (200°C)	T4A (120°C)
	8	4:1	20:1	NA	1000:1	T3 (200°C)	T4A (120°C)
447T	2, 4, 6	4:1	20:1	6:1	1000:1	T3 (200°C)	T4A (120°C)
	8	4:1	20:1	NA	1000:1	T3 (200°C)	T4A (120°C)
449T	2, 4, 6	4:1	20:1	NA	1000:1	T3 (200°C)	T4A (120°C)
	8	4:1	20:1	NA	1000:1	T3 (200°C)	T4A (120°C)
S449	2, 4, 6	4:1	20:1	NA	1000:1	T2D (215°C)	T4A (120°C)
	8	4:1	20:1	NA	1000:1	T2D (215°C)	T4A (120°C)
500 - 600 HP	2	3:1	20:1	NA	NA	T3 (200°C)	T4A (120°C)
	4	4:1	20:1	NA	NA	T3 (200°C)	T4A (120°C)
500 - 500 HP	6	2:1	20:1	NA	NA	T3 (200°C)	T4A (120°C)
500 - 800 HP	2	2:1	20:1	NA	NA	T2D (215°C)	T4A (120°C)
	4	2:1	20:1	NA	NA	T2D (215°C)	T4A (120°C)
500 - 600 HP	6	2:1	20:1	NA	NA	T2D (215°C)	T4A (120°C)

Table 15-1



Technical Notes

VSD Operation (continued)

Explosion Proof Motors (XP100, XP100 ID1)								
Frame	Poles	XP100				XP100 ID1		
		Standard		M05 Option	Temp Code	Standard		Temp Code
		Constant Torque	Variable Torque	Constant Torque		Constant Torque	Variable Torque	
143T - 145T	2, 4, 6	4:1	20:1	NA	T3C (160°C)	4:1	100:1	T2A (280°C)
	8	4:1	20:1	NA	T3C (160°C)	4:1	100:1	T2A (280°C)
182T - 184T	2, 4, 6	4:1	20:1	NA	T3C (160°C)	4:1	100:1	T2A (280°C)
	8	4:1	20:1	NA	T3C (160°C)	4:1	100:1	T2A (280°C)
213T - 215T	2, 4, 6	4:1	20:1	NA	T3C (160°C)	4:1	100:1	T2A (280°C)
	8	4:1	20:1	NA	T3C (160°C)	4:1	100:1	T2A (280°C)
254T - 256T	2, 4, 6	4:1	20:1	NA	T3C (160°C)	4:1	100:1	T2A (280°C)
	8	4:1	20:1	NA	T3C (160°C)	4:1	100:1	T2A (280°C)
284T - 286T	2, 4, 6	4:1	20:1	NA	T3C (160°C)	4:1	100:1	T2A (280°C)
	8	4:1	20:1	NA	T3C (160°C)	4:1	100:1	T2A (280°C)
324T - 326T	2, 4, 6	4:1	20:1	NA	T3C (160°C)	4:1	100:1	T2A (280°C)
	8	4:1	20:1	NA	T3C (160°C)	4:1	100:1	T2A (280°C)
364T - 365T	2, 4, 6	4:1 ¹⁾	20:1	6:1	T3C (160°C)	4:1	100:1	T2A (280°C)
	8	4:1 ¹⁾	20:1	NA	T3C (160°C)	4:1	100:1	T2A (280°C)
404T - 405T	2, 4, 6	4:1 ¹⁾	20:1	6:1	T3C (160°C)	4:1	100:1	T2A (280°C)
	8	4:1 ¹⁾	20:1	NA	T3C (160°C)	4:1	100:1	T2A (280°C)
444T - 445T	2, 4, 6	4:1 ¹⁾	20:1	6:1	T3C (160°C)	4:1	100:1	T2A (280°C)
	8	4:1 ¹⁾	20:1	NA	T3C (160°C)	4:1	100:1	T2A (280°C)
447T	2, 4, 6	4:1 ¹⁾	20:1	NA	T3C (160°C)	4:1	100:1	T2A (280°C)
	8	4:1 ¹⁾	20:1	NA	T3C (160°C)	4:1	100:1	T2A (280°C)
449T	2, 4, 6	4:1 ¹⁾	20:1	NA	T3C (160°C)	4:1	100:1	T2A (280°C)
	8	4:1 ¹⁾	20:1	NA	T3C (160°C)	4:1	100:1	T2A (280°C)

1) Only with De-rated output

Table 15-2

General Purpose Motors (GP100, GP100A)			
Frame	Poles	Standard	
		Constant Torque	Variable Torque
143T - 145T	2, 4, 6	4:1	20:1
	8	4:1	20:1
182T - 184T	2, 4, 6	4:1	20:1
	8	4:1	20:1
213T - 215T	2, 4, 6	4:1	20:1
	8	4:1	20:1
254T - 256T	2, 4, 6	4:1	20:1
	8	4:1	20:1
284T - 286T	2, 4, 6	4:1	20:1
	8	4:1	20:1
324T - 326T	2, 4, 6	4:1	20:1
	8	4:1	20:1
364T - 365T	2, 4, 6	4:1	20:1
	8	4:1	20:1
404T - 405T	2, 4, 6	4:1	20:1
	8	4:1	20:1
444T - 445T	2, 4, 6	4:1	20:1
	8	4:1	20:1
447T	2, 4, 6	4:1	20:1
	8	4:1	20:1
449T	2, 4, 6	4:1	20:1
	8	4:1	20:1

Table 15-3



SIMOTICS General Purpose Motors



Introduction

Special Features

Motor Selection and Pricing

Special Features Details

Typical Performance Details





General Dimensions

MV449 Frame

Indexes

Introduction

SIMOTICS General Purpose motors are designed and built to operate in a variety of commercial and industrial environments. These motors are design to meet or exceed the NEMA Premium® efficiency (MG1 Table 12-12). A wide selection of options makes them suitable for a variety of applications. The construction of these motors is backed up by its 18 month warranty.

Performance Specification			
		GP100A	GP100
HP Range	3600 RPM	1-20 HP	1-200 HP
	1800 RPM	1-20 HP	1-200 HP
	1200 RPM	1-20 HP	1-200 HP
	900 RPM	--	1-125 HP
Frame Size	140T - 440T	140T-250T	140T-449T
Standard Voltage (3~ 60 Hz)	230V/460V (Suitable for 208V)	FS 140-250	FS 140-250
	230V/460V	1-20 HP	Up to 75 HP
	460V	1-20 HP	1-200 HP
	575V	1-20 HP	1-200 HP
Efficiency	NEMA Premium® (MG1-Table 12-12)	1-20 HP	1-200 HP
	NEMA Premium® Plus (>MG1-Table 12-12)	1 - 20 HP	
Service Factor	1.15 @ 40°C	FS 140-250	FS 140-440
Insulation	Non-Hygroscopic	Class F	
Temperature Rise	Class B	@ 1.0SF	
	Class F	@ 1.15SF	
Conduit Box (Oversized)	Oversized	Aluminum FS 140-250	Steel - FS140-400
			Cast Iron - FS400
Fan Cover		Plastic	Plastic/Steel/Cast Iron
Cooling Fan	Bi-Directional	Polypropylene	
Rotor	Die Cast Aluminum	FS 140-250	FS 140-449
	Die Cast Copper ²⁾	FS 140-250	FS 140-250
Ingress Protection	NEMA MG1	IP55	
Hazardous Location	Safe Area	FS 140-250	FS 140-440
Inverter Duty	Variable Torque 20:1	FS 140-250	FS 140-440
	Constant Torque CT 4:1	FS 140-250	FS 140-440
	Constant Torque CT 10:1 ¹⁾	FS 140-250	
    			

1) Copper Rotor 2) NEMA Premium +



SIMOTICS General Purpose Motors

Frame and End Shields

The SIMOTICS General Purpose Motors are available in two different lines, GP100 which features a cast iron frame and end shields and GP100A with aluminum frame and endshields. Both offer an aluminum, easy-to-access, diagonally -split, oversize terminal box; the terminal box includes a heavy-duty ground lug and non-wicking clearly and permanently marked leads. These characteristics, its zinc-plated hardware, epoxy paint, and stainless steel nameplate provide exceptional structural integrity and resistance to rust and corrosion, and make them ideal for use in material handling, pump, fan compressor, and other industrial and commercial applications.

Rotor and Stator Windings

A unique offset rotor bar design provides improved efficiency, while larger bars and end rings reduce resistance for lower rotor losses. Each die cast aluminum rotor assembly is dynamically balanced for extended bearing life and includes a high-strength carbon steel (C1045) shaft for maximum rotor performance.. The stator is manufactured with premium electrical C5 grade steel lamination and copper electrical magnet wire that furthers the reduction in losses

Insulation

The proprietary Class F non-hygroscopic insulation system, NEMA Class B temperature rise, provides an extra margin of thermal life. The varnish system application ensures maximum wire penetration to provide protection from moisture, corrosion and electrical shock. This insulation system meets or exceeds NEMA MG1 2014 Part 31 making the motors suitable for variable speed drives in constant torque (up to 4:1) and variable torque (20:1). All windings are tested for CIV.

Cooling System

A non-sparking, bi-directional fan is locked and keyed to the shaft. Its low-inertia design reduces windage losses, improves airflow, reduces noise and provides dependable cooling. A durable and rigid plastic fan cover is offered on every frame size.

Bearings

The motor are equipped with antifriction ball bearings, double shielded up to frame size 250 for the drive end and frame size 280 and above on the non drive end; Frames 280 and above are provided with single shielded bearings on the drive end and they are also available with roller bearings, when roller bearings are used, the non drive end will be equipped with single shielded bearings.



GP100A

GP100A

GP100A (Aluminum Frame) Rotor: Die Cast Aluminum Eff: NEMA Premium					Delivery Category:			Stock	Quick Mod	Custom Build
Power HP	Speed Rpm	NEMA Frame	Base Part Number ■ ■ ■ = digits 14,15,16	Voltage	Digits 14,15,16			Eff	Weight Lbs	
					Foot Mounted	Foot Mounted C-Face	Round Body C-Face			
					AA3	EA3**	GA3**			
					List Price \$					
1	3600	143T	1LE2121-1AA11-4 ■ ■ ■	230/460*	429	535	519	82.5%	29	
1	1800	143T	1LE2121-1AB21-4 ■ ■ ■	230/460*	429	535	519	85.5%	41	
1	1200	145T	1LE2121-1AC31-4 ■ ■ ■	230/460*	533	639	623	82.5%	45	
1 1/2	3600	143T	1LE2121-1AA21-4 ■ ■ ■	230/460*	440	546	530	84.0%	35	
1 1/2	1800	145T	1LE2121-1AB31-4 ■ ■ ■	230/460*	471	577	561	86.5%	47	
1 1/2	1200	182T	1LE2121-1CC11-4 ■ ■ ■	230/460*	570	724	702	87.5%	63	
2	3600	145T	1LE2121-1AA31-4 ■ ■ ■	230/460*	511	617	601	85.5%	38	
2	1800	145T	1LE2121-1AB41-4 ■ ■ ■	230/460*	513	619	603	86.5%	46	
2	1200	184T	1LE2121-1CC31-4 ■ ■ ■	230/460*	629	783	761	88.5%	72	
3	3600	182T	1LE2121-1CA11-4 ■ ■ ■	230/460*	570	724	702	86.5%	57	
3	1800	182T	1LE2121-1CB11-4 ■ ■ ■	230/460*	590	744	722	89.5%	68	
3	1200	213T	1LE2121-2AC11-4 ■ ■ ■	230/460*	809	973	941	89.5%	104	
5	3600	184T	1LE2121-1CA31-4 ■ ■ ■	230/460*	741	895	873	88.5%	67	
5	1800	184T	1LE2121-1CB31-4 ■ ■ ■	230/460*	671	825	803	89.5%	74	
5	1200	215T	1LE2121-2AC21-4 ■ ■ ■	230/460*	1,207	1,371	1,339	89.5%	116	
7 1/2	3600	213T	1LE2121-2AA11-4 ■ ■ ■	230/460*	969	1,133	1,101	89.5%	100	
7 1/2	1800	213T	1LE2121-2AB11-4 ■ ■ ■	230/460*	939	1,103	1,071	91.7%	130	
7 1/2	1200	254T	1LE2121-2BC11-4 ■ ■ ■	230/460*	1,540	1,769	1,720	91.0%	200	
10	3600	215T	1LE2121-2AA21-4 ■ ■ ■	230/460*	1,142	1,306	1,274	90.2%	113	
10	1800	215T	1LE2121-2AB21-4 ■ ■ ■	230/460*	1,142	1,306	1,274	91.7%	136	
10	1200	256T	1LE2121-2BC21-4 ■ ■ ■	230/460*	1,814	2,043	1,994	91.0%	196	
15	3600	254T	1LE2121-2BA11-4 ■ ■ ■	230/460*	1,493	1,722	1,673	91.0%	196	
15	1800	254T	1LE2121-2BB11-4 ■ ■ ■	230/460*	1,457	1,686	1,637	92.4%	198	
20	3600	256T	1LE2121-2BA21-4 ■ ■ ■	230/460*	1,848	2,077	2,028	91.0%	231	
20	1800	256T	1LE2121-2BB21-4 ■ ■ ■	230/460*	1,755	1,984	1,935	93.0%	229	

*Suitable for 208V

**Add 'C' after frame. Ex. 184TC

NEMA Premium is a certification mark of the National Electrical Manufacturer's Association.

QuikMOD Delivery is for stocked motors only.



SIMOTICS General Purpose Motors

GP100A Cu

GP100A (Aluminum Frame) Rotor: Die Cast Copper Eff: NEMA Premium +					Delivery Category:			Stock	Quick Mod	Custom Build
Power HP	Speed Rpm	NEMA Frame	Base Part Number ■ ■ ■ = digits 14,15,16	Voltage	Digits 14,15,16			Eff	Weight Lbs	
					Foot Mounted	Foot Mounted C-Face	Round Body C-Face			
					AA3	EA3**	GA3**			
					List Price \$					
1	1800	143T	1LE2111-1AB21-4 ■ ■ ■	230/460*	476	582	566	86.5%	47	
1	1200	145T	1LE21111AC31-4 ■ ■ ■	230/460*	593	699	683	84.0%	48	
1 1/2	3600	143T	1LE21111AA21-4 ■ ■ ■	230/460*	488	594	578	87.5%	45	
1 1/2	1800	145T	1LE21111AB31-4 ■ ■ ■	230/460*	524	630	614	87.5%	48	
2	3600	145T	1LE21111AA31-4 ■ ■ ■	230/460*	567	673	657	88.5%	45	
2	1800	145T	1LE21111AB41-4 ■ ■ ■	230/460*	569	675	659	87.5%	48	
3	3600	182T	1LE21111CA11-4 ■ ■ ■	230/460*	633	787	765	89.5%	71	
3	1800	182T	1LE21111CB11-4 ■ ■ ■	230/460*	656	810	788	90.2%	75	
3	1200	213T	1LE21112AC11-4 ■ ■ ■	230/460*	899	1,063	1,031	90.2%	110	
5	3600	184T	1LE21111CA31-4 ■ ■ ■	230/460*	824	978	956	90.2%	73	
5	1800	184T	1LE21111CB31-4 ■ ■ ■	230/460*	746	900	878	90.2%	79	
5	1200	215T	1LE21112AC21-4 ■ ■ ■	230/460*	1,340	1,504	1,472	90.2%	123	
7 1/2	3600	213T	1LE21112AA11-4 ■ ■ ■	230/460*	1,076	1,240	1,208	91.7%	130	
7 1/2	1800	213T	1LE21112AB11-4 ■ ■ ■	230/460*	1,043	1,207	1,175	92.4%	137	
7 1/2	1200	254T	1LE21112BC11-4 ■ ■ ■	230/460*	1,796	2,025	1,976	92.4%	244	
10	3600	215T	1LE21112AA21-4 ■ ■ ■	230/460*	1,269	1,433	1,401	91.7%	135	
10	1800	215T	1LE21112AB21-4 ■ ■ ■	230/460*	1,269	1,433	1,401	92.4%	144	
10	1200	256T	1LE21112BC21-4 ■ ■ ■	230/460*	2,115	2,344	2,295	92.4%	245	
15	3600	254T	1LE21112BA11-4 ■ ■ ■	230/460*	1,742	1,971	1,922	92.4%	218	
15	1800	254T	1LE21112BB11-4 ■ ■ ■	230/460*	1,701	1,930	1,881	93.0%	207	
20	3600	256T	1LE21112BA21-4 ■ ■ ■	230/460*	2,156	2,385	2,336	92.4%	241	
20	1800	256T	1LE21112BB21-4 ■ ■ ■	230/460*	2,046	2,275	2,226	93.6%	248	

*Suitable for 208V

**Add 'C' after frame. Ex. 184TC

NEMA Premium is a certification mark of the National Electrical Manufacturer's Association.

QuikMOD Delivery is for stocked motors only.



SIMOTICS General Purpose Motors

GP100A 575

GP100A (Aluminum Frame) Rotor: Die Cast Aluminum Eff: NEMA Premium					Delivery Category:			Stock	Quick Mod	Custom Build
Power HP	Speed Rpm	NEMA Frame	Base Part Number ■ ■ ■ = digits 14,15,16	Voltage	Digits 14,15,16			Eff	Weight Lbs	
					Foot Mounted	Foot Mounted C-Face	Round Body C-Face			
					AA3	EA3**	GA3**			
					List Price \$					
1	3600	143T	1LE2121-1AA11-3 ■ ■ ■	575	429	535	519	82.5%	29	
1	1800	143T	1LE2121-1AB21-3 ■ ■ ■	575	429	535	519	85.5%	41	
1	1200	145T	1LE2121-1AC31-3 ■ ■ ■	575	533	639	623	82.5%	45	
1 1/2	3600	143T	1LE2121-1AA21-3 ■ ■ ■	575	440	546	530	84.0%	35	
1 1/2	1800	145T	1LE2121-1AB31-3 ■ ■ ■	575	471	577	561	86.5%	47	
1 1/2	1200	182T	1LE2121-1CC11-3 ■ ■ ■	575	570	724	702	87.5%	63	
2	3600	145T	1LE2121-1AA31-3 ■ ■ ■	575	511	617	601	85.5%	38	
2	1800	145T	1LE2121-1AB41-3 ■ ■ ■	575	513	619	603	86.5%	46	
2	1200	184T	1LE2121-1CC31-3 ■ ■ ■	575	629	783	761	88.5%	72	
3	3600	182T	1LE2121-1CA11-3 ■ ■ ■	575	570	724	702	86.5%	57	
3	1800	182T	1LE2121-1CB11-3 ■ ■ ■	575	590	744	722	89.5%	68	
3	1200	213T	1LE2121-2AC11-3 ■ ■ ■	575	809	973	941	89.5%	104	
5	3600	184T	1LE2121-1CA31-3 ■ ■ ■	575	741	895	873	88.5%	67	
5	1800	184T	1LE2121-1CB31-3 ■ ■ ■	575	671	825	803	89.5%	74	
5	1200	215T	1LE2121-2AC21-3 ■ ■ ■	575	1,207	1371	1,339	89.5%	116	
7 1/2	3600	213T	1LE2121-2AA11-3 ■ ■ ■	575	969	1133	1,101	89.5%	100	
7 1/2	1800	213T	1LE2121-2AB11-3 ■ ■ ■	575	939	1,103	1,071	91.7%	130	
7 1/2	1200	254T	1LE2121-2BC11-3 ■ ■ ■	575	1,540	1769	1,720	91.0%	200	
10	3600	215T	1LE2121-2AA21-3 ■ ■ ■	575	1,142	1306	1,274	90.2%	113	
10	1800	215T	1LE2121-2AB21-3 ■ ■ ■	575	1,142	1306	1,274	91.7%	136	
10	1200	256T	1LE2121-2BC21-3 ■ ■ ■	575	1,814	2043	1,994	91.0%	196	
15	3600	254T	1LE2121-2BA11-3 ■ ■ ■	575	1,493	1722	1,673	91.0%	196	
15	1800	254T	1LE2121-2BB11-3 ■ ■ ■	575	1,457	1,686	1,637	92.4%	198	
20	3600	256T	1LE2121-2BA21-3 ■ ■ ■	575	1,848	2077	2,028	91.0%	231	
20	1800	256T	1LE2121-2BB21-3 ■ ■ ■	575	1,755	1984	1,935	93.0%	229	

**Add 'C' after frame. Ex. 184TC

NEMA Premium is a certification mark of the National Electrical Manufacturer's Association.

QuikMOD Delivery is for stocked motors only.



SIMOTICS General Purpose Motors

GP100

GP100 (Cast Iron Frame) Rotor: Die Cast Aluminum Eff: NEMA Premium					Delivery Category:			Stock	Quick Mod	Custom Build
Power HP	Speed Rpm	NEMA Frame	Base Part Number ■ ■ ■ = digits 14,15,16	Voltage	Digits 14,15,16			Eff	Weight Lbs	
					Foot Mounted	Foot Mounted C-Face	Round Body C-Face			
					AA3	EA3**	GA3**			
					List Price \$					
1	3600	143T	1LE2221-1AA11-4 ■■■	230/460*	454	560	544	82.5%	60	
1	1800	143T	1LE2221-1AB21-4 ■■■	230/460*	454	560	544	85.5%	62	
1	1200	145T	1LE2221-1AC31-4 ■■■	230/460*	563	669	653	82.5%	64	
1	900	182T	1LE2221-1CD11-4 ■■■	230/460*	682	836	814	74.0%	86	
1 1/2	3600	143T	1LE2221-1AA21-4 ■■■	230/460*	466	572	556	84.0%	56	
1 1/2	1800	145T	1LE2221-1AB31-4 ■■■	230/460*	500	606	590	86.5%	66	
1 1/2	1200	182T	1LE2221-1CC11-4 ■■■	230/460*	602	756	734	87.5%	93	
1 1/2	900	184T	1LE2221-1CD31-4 ■■■	230/460*	741	895	873	77.0%	99	
2	3600	145T	1LE2221-1AA31-4 ■■■	230/460*	540	646	630	85.5%	59	
2	1800	145T	1LE2221-1AB41-4 ■■■	230/460*	542	648	632	86.5%	66	
2	1200	184T	1LE2221-1CC31-4 ■■■	230/460*	666	820	798	88.5%	102	
2	900	213T	1LE2221-2AD11-4 ■■■	230/460*	852	1,016	984	82.5%	123	
3	3600	182T	1LE2221-1CA11-4 ■■■	230/460*	602	756	734	86.5%	87	
3	1800	182T	1LE2221-1CB11-4 ■■■	230/460*	623	777	755	89.5%	98	
3	1200	213T	1LE2221-2AC11-4 ■■■	230/460*	857	1,021	989	89.5%	144	
3	900	215T	1LE2221-2AD21-4 ■■■	230/460*	1,222	1,386	1,354	84.0%	138	
5	3600	184T	1LE2221-1CA31-4 ■■■	230/460*	784	938	916	88.5%	98	
5	1800	184T	1LE2221-1CB31-4 ■■■	230/460*	709	863	841	89.5%	104	
5	1200	215T	1LE2221-2AC21-4 ■■■	230/460*	1,277	1,441	1,409	89.5%	156	
5	900	254T	1LE2221-2BD11-4 ■■■	230/460*	1,774	2,003	1,954	85.5%	218	
7 1/2	3600	213T	1LE2221-2AA11-4 ■■■	230/460*	1,025	1,189	1,157	89.5%	148	
7 1/2	1800	213T	1LE2221-2AB11-4 ■■■	230/460*	994	1,158	1,126	91.7%	171	
7 1/2	1200	254T	1LE2221-2BC11-4 ■■■	230/460*	1,630	1,859	1,810	91.0%	262	
7 1/2	900	256T	1LE2221-2BD21-4 ■■■	230/460*	1,787	2,016	1,967	85.5%	250	
10	3600	215T	1LE2221-2AA21-4 ■■■	230/460*	1,209	1,373	1,341	90.2%	163	
10	1800	215T	1LE2221-2AB21-4 ■■■	230/460*	1,209	1,373	1,341	91.7%	177	
10	1200	256T	1LE2221-2BC21-4 ■■■	230/460*	1,918	2,147	2,098	91.0%	259	
10	900	284T	1LE2221-2CD11-6 ■■■	230/460*	2,569	1,810	1,761	90.2%	414	
15	3600	254T	1LE2221-2BA11-4 ■■■	230/460*	1,581	1,771	1,722	91.0%	258	
15	1800	254T	1LE2221-2BB11-4 ■■■	230/460*	1,542	2,184	2,135	92.4%	259	
15	1200	284T	1LE2221-2CC11-6 ■■■	230/460*	2,510	2,086	2,037	91.7%	409	
15	900	286T	1LE2221-2CD21-6 ■■■	230/460*	3,051	3,921	3,990	91.0%	459	
20	3600	256T	1LE2221-2BA21-4 ■■■	230/460*	1,955	2,184	2,135	91.0%	293	
20	1800	256T	1LE2221-2BB21-4 ■■■	230/460*	1,857	2,086	2,037	93.0%	292	
20	1200	286T	1LE2221-2CC21-6 ■■■	230/460*	2,956	3,826	3,895	91.7%	434	
20	900	324T	1LE2221-3AD11-6 ■■■	230/460*	3,664	4,605	4,693	91.0%	616	

*Suitable for 208V

**Add 'C' after frame. Ex. 184TC

NEMA Premium is a certification mark of the National Electrical Manufacturer's Association.

QuikMOD Delivery is for stocked motors only.



SIMOTICS General Purpose Motors

GP100 (Continued)

GP100 (Cast Iron Frame) Rotor: Die Cast Aluminum Eff: NEMA Premium					Delivery Category:			Stock	Quick Mod	Custom Build
Power HP	Speed Rpm	NEMA Frame	Base Part Number ■ ■ ■ = digits 14,15,16	Voltage	Digits 14,15,16			Eff	Weight Lbs	
					Foot Mounted	Foot Mounted C-Face	Round Body C-Face			
					AA3	EA3**	GA3**			
					List Price \$					
25	3600	284TS	1LE2221-2DA11-6 ■■■	230/460*	2,268	3,138	3,207	91.7%	454	
25	1800	284T	1LE2221-2CB11-6 ■■■	230/460*	2,164	3,034	3,103	93.6%	429	
25	1200	324T	1LE2221-3AC11-6 ■■■	230/460*	3,565	4,506	4,594	93.0%	633	
25	900	326T	1LE2221-3AD21-6 ■■■	230/460*	4,242	5,183	5,271	91.0%	663	
30	3600	286TS	1LE2221-2DA21-6 ■■■	230/460*	2,751	3,621	3,690	91.7%	424	
30	1800	286T	1LE2221-2CB21-6 ■■■	230/460*	2,616	3,486	3,555	93.6%	449	
30	1200	326T	1LE2221-3AC21-6 ■■■	230/460*	4,387	5,328	5,416	93.0%	658	
30	900	364T	1LE2221-3CD11-6 ■■■	230/460*	5,449	6,465	6,757	91.7%	854	
40	3600	324TS	1LE2221-3BA11-6 ■■■	230/460*	3,679	4,620	4,708	93.6%	608	
40	1800	324T	1LE2221-3AB11-6 ■■■	230/460*	3,522	4,463	4,551	94.1%	633	
40	1200	364T	1LE2221-3CC11-6 ■■■	230/460*	6,032	7,048	7,340	94.1%	828	
40	900	365T	1LE2221-3CD21-6 ■■■	230/460*	6,436	7,452	7,744	91.7%	950	
50	3600	326TS	1LE2221-3BA21-6 ■■■	230/460*	4,871	5,812	5,900	93.6%	593	
50	1800	326T	1LE2221-3AB21-6 ■■■	230/460*	4,428	5,369	5,457	94.5%	668	
50	1200	365T	1LE2221-3CC21-6 ■■■	230/460*	7,088	8,104	8,396	94.1%	863	
60	3600	364TS	1LE2221-3DA11-6 ■■■	230/460*	5,675	6,691	6,983	93.6%	780	
60	1800	364T	1LE2221-3CB11-6 ■■■	230/460*	5,625	6,641	6,933	95.0%	880	
60	1200	404T	1LE2221-4AC11-6 ■■■	230/460*	7,354	8,615	9,038	94.5%	1047	
75	3600	365TS	1LE2221-3DA21-6 ■■■	230/460*	7,091	8,107	8,399	94.1%	888	
75	1800	365T	1LE2221-3CB21-6 ■■■	230/460*	7,096	8,112	8,404	95.4%	950	
75	1200	405T	1LE2221-4AC21-6 ■■■	230/460*	8,615	9,876	10,299	94.5%	1117	
100	3600	405TS	1LE2221-4BA21-2 ■■■	460	10,347	11,608	12,031	94.1%	1012	
100	1800	405T	1LE2221-4AB21-2 ■■■	460	9,547	10,808	11,231	95.4%	1107	
100	1800	405TS	1LE2221-4BB21-2 ■■■	460	9,547	10,808	11,231	95.4%	1107	
100	1200	R444T	1LE2221-4CC11-2 ■■■	460	13,429	--	--	95.0%	1531	
100	1200	444TS	1LE2221-4DC11-2 ■■■	460	12,821	14,314	15,124	95.0%	1467	
125	3600	444TS	1LE2221-4DA11-2 ■■■	460	12,831	14,324	15,134	95.0%	1381	
125	1800	R444T	1LE2221-4CB11-2 ■■■	460	12,532	--	--	95.4%	1590	
125	1800	444T	1LE2221-4EB11-2 ■■■	460	11,924	13,417	14,227	95.4%	1552	
125	1800	444TS	1LE2221-4DB11-2 ■■■	460	11,924	13,417	14,227	95.4%	1552	
125	1200	R445T	1LE2221-4CC21-2 ■■■	460	15,550	--	--	95.0%	1702	
125	1200	445T	1LE2221-4EC21-2 ■■■	460	14,942	16,435	17,245	95.0%	1664	
125	1200	445TS	1LE2221-4DC21-2 ■■■	460	14,942	16,435	17,245	95.0%	1647	
150	3600	445TS	1LE2221-4DA21-2 ■■■	460	15,967	17,460	18,270	95.0%	1542	
150	1800	R445T	1LE2221-4CB21-2 ■■■	460	14,967	--	--	95.8%	1865	
150	1800	445T	1LE2221-4EB21-2 ■■■	460	14,359	15,852	16,662	95.8%	1827	
150	1800	445TS	1LE2221-4DB21-2 ■■■	460	14,359	15,852	16,662	95.8%	1637	
150	1200	R447T	1LE2221-4CC31-2 ■■■	460	17,925	--	--	95.8%	1960	
150	1200	447T	1LE2221-4EC31-2 ■■■	460	17,317	18,810	19,620	95.8%	1922	
150	1200	447TS	1LE2221-4DC31-2 ■■■	460	17,317	18,810	19,620	95.8%	1897	

*Suitable for 208V

**Add 'C' after frame. Ex. 184TC

NEMA Premium is a certification mark of the National Electrical Manufacturer's Association.

QuikMOD Delivery is for stocked motors only.



SIMOTICS General Purpose Motors

GP100 (Continued)

GP100 (Cast Iron Frame) Rotor: Die Cast Aluminum Eff: NEMA Premium					Delivery Category:			Stock	Quick Mod	Custom Build
Power HP	Speed Rpm	NEMA Frame	Base Part Number ■ ■ ■ = digits 14,15,16	Voltage	Digits 14,15,16			Eff	Weight Lbs	
					Foot Mounted	Foot Mounted C-Face	Round Body C-Face			
					AA3	EA3**	GA3**			
					List Price \$					
200	3600	447TS	1LE2221-4DA31-2 ■ ■ ■	460	22,239	23,732	24,542	95.4%	2182	
200	1800	R447T	1LE2221-4CB31-2 ■ ■ ■	460	19,838	--	--	96.2%	2245	
200	1800	447T	1LE2221-4EB31-2 ■ ■ ■	460	19,230	20,723	21,533	96.2%	2207	
200	1800	447TS	1LE2221-4DB31-2 ■ ■ ■	460	19,230	20,723	21,533	96.2%	2182	
200	1200	R449T	1LE2221-4CC51-2 ■ ■ ■	460	23,948	--	--	95.8%	2301	
200	1200	449T	1LE2221-4EC51-2 ■ ■ ■	460	23,340	24,833	25,643	95.8%	2263	
200	1200	449TS	1LE2221-4DC51-2 ■ ■ ■	460	23,340	24,833	25,643	95.8%	2240	

*Suitable for 208V

**Add 'C' after frame. Ex. 184TC

Note - 'R' before the frame designates the motor has Roller bearings

NEMA Premium is a certification mark of the National Electrical Manufacturer's Association.

QuikMOD Delivery is for stocked motors only.



SIMOTICS General Purpose Motors

GP100 Cu

GP100 (Cast Iron Frame) Rotor: Die Cast Copper Eff: NEMA Premium +					Delivery Category:			Stock		
								Quick Mod		
								Custom Build		
Power HP	Speed Rpm	NEMA Frame	Base Part Number ■ ■ ■ = digits 14,15,16	Voltage	Digits 14,15,16			Eff	Weight Lbs	
					Foot Mounted	Foot Mounted C-Face	Round Body C-Face			
					AA3	EA3**	GA3**			
					List Price \$					
1	1800	143T	1LE22111AB21-4 ■ ■ ■	230/460*	505	611	595	86.5%	60	
1	1200	145T	1LE22111AC31-4 ■ ■ ■	230/460*	628	734	718	84.0%	62	
1 1/2	3600	143T	1LE22111AA21-4 ■ ■ ■	230/460*	519	625	609	87.5%	64	
1 1/2	1800	145T	1LE22111AB31-4 ■ ■ ■	230/460*	556	662	646	87.5%	86	
2	3600	145T	1LE2211-1AA31-4 ■ ■ ■	230/460*	602	708	692	88.5%	56	
2	1800	145T	1LE2211-1AB41-4 ■ ■ ■	230/460*	604	710	694	87.5%	66	
3	3600	182T	1LE2211-1CA11-4 ■ ■ ■	230/460*	672	826	804	89.5%	93	
3	1800	182T	1LE2211-1CB11-4 ■ ■ ■	230/460*	695	849	827	90.2%	99	
3	1200	213T	1LE2211-2AC11-4 ■ ■ ■	230/460*	955	1,119	1,087	90.2%	59	
5	3600	184T	1LE2211-1CA31-4 ■ ■ ■	230/460*	874	1,028	1,006	90.2%	66	
5	1800	184T	1LE2211-1CB31-4 ■ ■ ■	230/460*	791	945	923	90.2%	102	
5	1200	215T	1LE2211-2AC21-4 ■ ■ ■	230/460*	1,423	1,587	1,555	90.2%	123	
7 1/2	3600	213T	1LE2211-2AA11-4 ■ ■ ■	230/460*	1,143	1,307	1,275	91.7%	87	
7 1/2	1800	213T	1LE2211-2AB11-4 ■ ■ ■	230/460*	1,107	1,271	1,239	92.4%	98	
7 1/2	1200	254T	1LE2211-2BC11-4 ■ ■ ■	230/460*	1,908	2,137	2,088	92.4%	144	
10	3600	215T	1LE2211-2AA21-4 ■ ■ ■	230/460*	1,347	1,511	1,479	91.7%	138	
10	1800	215T	1LE2211-2AB21-4 ■ ■ ■	230/460*	1,348	1,512	1,480	92.4%	98	
10	1200	256T	1LE2211-2BC21-4 ■ ■ ■	230/460*	2,244	2,473	2,424	92.4%	104	
15	3600	254T	1LE2211-2BA11-4 ■ ■ ■	230/460*	1,849	2,078	2,029	92.4%	156	
15	1800	254T	1LE2211-2BB11-4 ■ ■ ■	230/460*	1,804	2,033	1,984	93.0%	218	
20	3600	256T	1LE2211-2BA21-4 ■ ■ ■	230/460*	2,288	2,517	2,468	92.4%	148	
20	1800	256T	1LE2211-2BB21-4 ■ ■ ■	230/460*	2,172	2,401	2,352	93.6%	171	

*Suitable for 208V

**Add 'C' after frame. Ex. 184TC

Note - 'R' before the frame designates the motor has Roller bearings

NEMA Premium is a certification mark of the National Electrical Manufacturer's Association.

QuikMOD Delivery is for stocked motors only.



SIMOTICS General Purpose Motors

GP100 575

GP100 (Cast Iron Frame) Rotor: Die Cast Aluminum Eff: NEMA Premium					Delivery Category:			Stock	Quick Mod	Custom Build
Power HP	Speed Rpm	NEMA Frame	Base Part Number ■ ■ ■ = digits 14,15,16	Voltage	Digits 14,15,16			Eff	Weight Lbs	
					Foot Mounted	Foot Mounted C-Face	Round Body C-Face			
					AA3	EA3**	GA3**			
					List Price \$					
1	3600	143T	1LE2221-1AA11-3 ■■■	575	454	560	544	82.5%	60	
1	1800	143T	1LE2221-1AB21-3 ■■■	575	454	560	544	85.5%	62	
1	1200	145T	1LE2221-1AC31-3 ■■■	575	563	669	653	82.5%	64	
1	900	182T	1LE2221-1CD11-3 ■■■	575	682	836	814	74.0%	86	
1 1/2	3600	143T	1LE2221-1AA21-3 ■■■	575	466	572	556	84.0%	56	
1 1/2	1800	145T	1LE2221-1AB31-3 ■■■	575	500	606	590	86.5%	66	
1 1/2	1200	182T	1LE2221-1CC11-3 ■■■	575	602	756	734	87.5%	93	
1 1/2	900	184T	1LE2221-1CD31-3 ■■■	575	741	895	873	77.0%	99	
2	3600	145T	1LE2221-1AA31-3 ■■■	575	540	646	630	85.5%	59	
2	1800	145T	1LE2221-1AB41-3 ■■■	575	542	648	632	86.5%	66	
2	1200	184T	1LE2221-1CC31-3 ■■■	575	666	820	798	88.5%	102	
2	900	213T	1LE2221-2AD11-3 ■■■	575	852	1,016	984	82.5%	123	
3	3600	182T	1LE2221-1CA11-3 ■■■	575	602	756	734	86.5%	87	
3	1800	182T	1LE2221-1CB11-3 ■■■	575	623	777	755	89.5%	98	
3	1200	213T	1LE2221-2AC11-3 ■■■	575	857	1,021	989	89.5%	144	
3	900	215T	1LE2221-2AD21-3 ■■■	575	1,222	1,386	1,354	84.0%	138	
5	3600	184T	1LE2221-1CA31-3 ■■■	575	784	938	916	88.5%	98	
5	1800	184T	1LE2221-1CB31-3 ■■■	575	709	863	841	89.5%	104	
5	1200	215T	1LE2221-2AC21-3 ■■■	575	1,277	1,441	1,409	89.5%	156	
5	900	254T	1LE2221-2BD11-3 ■■■	575	1,774	2,003	1,954	85.5%	218	
7 1/2	3600	213T	1LE2221-2AA11-3 ■■■	575	1,025	1,189	1,157	89.5%	148	
7 1/2	1800	213T	1LE2221-2AB11-3 ■■■	575	994	1,158	1,126	91.7%	171	
7 1/2	1200	254T	1LE2221-2BC11-3 ■■■	575	1,630	1,859	1,810	91.0%	262	
7 1/2	900	256T	1LE2221-2BD21-3 ■■■	575	1,787	2,016	1,967	85.0%	250	
10	3600	215T	1LE2221-2AA21-3 ■■■	575	1,209	1,373	1,341	90.2%	163	
10	1800	215T	1LE2221-2AB21-3 ■■■	575	1,209	1,373	1,341	91.7%	177	
10	1200	256T	1LE2221-2BC21-3 ■■■	575	1,918	2,147	2,098	91.0%	259	
10	900	284T	1LE2221-2CD11-3 ■■■	575	2,569	1,810	1,761	90.2%	414	
15	3600	254T	1LE2221-2BA11-3 ■■■	575	1,581	1,771	1,722	91.0%	258	
15	1800	254T	1LE2221-2BB11-3 ■■■	575	1,542	2,184	2,135	92.4%	259	
15	1200	284T	1LE2221-2CC11-3 ■■■	575	2,510	2,086	2,037	91.7%	409	
15	900	286T	1LE2221-2CD21-3 ■■■	575	3,051	3,921	3,990	91.0%	459	
20	3600	256T	1LE2221-2BA21-3 ■■■	575	1,955	2,184	2,135	91.0%	293	
20	1800	256T	1LE2221-2BB21-3 ■■■	575	1,857	2,086	2,037	93.0%	292	
20	1200	286T	1LE2221-2CC21-3 ■■■	575	2,956	3,826	3,895	91.7%	434	
20	900	324T	1LE2221-3AD11-3 ■■■	575	3,664	4,605	4,693	91.0%	616	

**Add 'C' after frame. Ex. 184TC

Note - 'R' before the frame designates the motor has Roller bearings

NEMA Premium is a certification mark of the National Electrical Manufacturer's Association.

QuikMOD Delivery is for stocked motors only.



SIMOTICS General Purpose Motors

GP100 575 (Continued)

GP100 (Cast Iron Frame) Rotor: Die Cast Aluminum Eff: NEMA Premium					Delivery Category:			Stock	
								Quick Mod	
								Custom Build	
Power HP	Speed Rpm	NEMA Frame	Base Part Number ■ ■ ■ = digits 14,15,16	Voltage	Digits 14,15,16			Eff	Weight Lbs
					Foot Mounted	Foot Mounted C-Face	Round Body C-Face		
					AA3	EA3**	GA3**		
					List Price \$				
25	3600	284TS	1LE2221-2DA11-3 ■■■	575	2,268	3,138	3,207	91.7%	454
25	1800	284T	1LE2221-2CB11-3 ■■■	575	2,164	3,034	3,103	93.6%	429
25	1200	324T	1LE2221-3AC11-3 ■■■	575	3,565	4,506	4,594	93.0%	633
25	900	326T	1LE2221-3AD21-3 ■■■	575	4,242	5,183	5,271	91.0%	663
30	3600	286TS	1LE2221-2DA21-3 ■■■	575	2,751	3,621	3,690	91.7%	424
30	1800	286T	1LE2221-2CB21-3 ■■■	575	2,616	3,486	3,555	93.6%	449
30	1200	326T	1LE2221-3AC21-3 ■■■	575	4,387	5,328	5,416	93.0%	658
30	900	364T	1LE2221-3CD11-3 ■■■	575	5,449	6,465	6,757	91.0%	854
40	3600	324TS	1LE2221-3BA11-3 ■■■	575	3,679	4,620	4,708	93.6%	608
40	1800	324T	1LE2221-3AB11-3 ■■■	575	3,522	4,463	4,551	94.1%	633
40	1200	364T	1LE2221-3CC11-3 ■■■	575	6,032	7,048	7,340	94.1%	828
40	900	365T	1LE2221-3CD21-3 ■■■	575	6,436	7,452	7,744	91.7%	950
50	3600	326TS	1LE2221-3BA21-3 ■■■	575	4,871	5,812	5,900	93.6%	539
50	1800	326T	1LE2221-3AB21-3 ■■■	575	4,428	5,369	5,457	94.5%	668
50	1200	365T	1LE2221-3CC21-3 ■■■	575	7,088	8,104	8,396	94.1%	863
60	3600	364TS	1LE2221-3DA11-3 ■■■	575	5,675	6,691	6,983	93.6%	780
60	1800	364T	1LE2221-3CB11-3 ■■■	575	5,625	6,641	6,933	95.0%	880
60	1200	404T	1LE2221-4AC11-3 ■■■	575	7,354	8,615	9,038	94.5%	1047
75	3600	365TS	1LE2221-3DA21-3 ■■■	575	7,091	8,107	8,399	94.1%	888
75	1800	365T	1LE2221-3CB21-3 ■■■	575	7,096	8,112	8,404	95.4%	950
75	1200	405T	1LE2221-4AC21-3 ■■■	575	8,615	9,876	10,299	94.5%	1117
100	3600	405TS	1LE2221-4BA21-3 ■■■	575	10,347	11,608	12,031	94.1%	1012
100	1800	405T	1LE2221-4AB21-3 ■■■	575	9,547	10,808	11,231	95.4%	1107
100	1200	R444T	1LE2221-4CC11-3 ■■■	575	13,429	--	--	95.0%	1531
125	3600	444TS	1LE2221-4DA11-3 ■■■	575	12,831	14,324	15,134	95.0%	1381
125	1800	R444T	1LE2221-4CB11-3 ■■■	575	12,532	--	--	95.4%	1527
125	1800	444T	1LE2221-4EB11-3 ■■■	575	11,924	13,417	14,227	95.4%	1552
125	1800	444TS	1LE2221-4DB11-3 ■■■	575	11,924	13,417	14,227	95.4%	1527
125	1200	R445T	1LE2221-4CC21-3 ■■■	575	15,550	--	--	95.0%	1702
125	1200	445T	1LE2221-4EC21-3 ■■■	575	14,942	16,435	17,245	95.0%	1664
125	1200	445TS	1LE2221-4DC21-3 ■■■	575	14,942	16,435	17,245	95.0%	1647
150	3600	445TS	1LE2221-4DA21-3 ■■■	575	15,967	17,460	18,270	95.0%	1542
150	1800	R445T	1LE2221-4CB21-3 ■■■	575	14,967	--	--	95.8%	1865
150	1800	445T	1LE2221-4EB21-3 ■■■	575	14,359	15,852	16,662	95.8%	1827
150	1800	445TS	1LE2221-4DB21-3 ■■■	575	14,359	15,852	16,662	95.8%	1637
150	1200	R447T	1LE2221-4CC31-3 ■■■	575	17,925	--	--	95.8%	1960
150	1200	447T	1LE2221-4EC31-3 ■■■	575	17,317	18,810	19,620	95.8%	1922
150	1200	447TS	1LE2221-4DC31-3 ■■■	575	17,317	18,810	19,620	95.8%	1867

**Add 'C' after frame. Ex. 184TC

Note - 'R' before the frame designates the motor has Roller bearings

NEMA Premium is a certification mark of the National Electrical Manufacturer's Association.

QuikMOD Delivery is for stocked motors only.



SIMOTICS General Purpose Motors

GP100 575 (Continued)

GP100 (Cast Iron Frame) Rotor: Die Cast Aluminum Eff: NEMA Premium					Delivery Category:			Stock	Quick Mod	Custom Build
Power HP	Speed Rpm	NEMA Frame	Base Part Number ■ ■ ■ = digits 14,15,16	Voltage	Digits 14,15,16			Eff	Weight Lbs	
					Foot Mounted	Foot Mounted C-Face	Round Body C-Face			
					AA3	EA3**	GA3**			
					List Price \$					
200	3600	447TS	1LE2221-4DA31-3 ■ ■ ■	575	22,239	23,732	24,542	95.4%	2182	
200	1800	R447T	1LE2221-4CB31-3 ■ ■ ■	575	19,838	--	--	96.2%	2245	
200	1800	447T	1LE2221-4EB31-3 ■ ■ ■	575	19,230	20,723	21,533	96.2%	2207	
200	1800	447TS	1LE2221-4DB31-3 ■ ■ ■	575	19,230	20,723	21,533	96.2%	2182	
200	1200	R449T	1LE2221-4CC51-3 ■ ■ ■	575	23,948	--	--	95.8%	2301	
200	1200	449T	1LE2221-4EC51-3 ■ ■ ■	575	23,340	24,833	25,643	95.8%	2263	
200	1200	449TS	1LE2221-4DC51-3 ■ ■ ■	575	23,340	24,833	25,643	95.8%	2240	

**Add 'C' after frame. Ex. 184TC

Note - 'R' before the frame designates the motor has Roller bearings

NEMA Premium is a certification mark of the National Electrical Manufacturer's Association.

QuikMOD Delivery is for stocked motors only.



SIMOTICS Severe Duty Motors



Introduction

Special Features

Motor Selection and Pricing

Special Features Details

Typical Performance Details







General Dimensions

MV449 Frame

Indexes

Introduction

Siemens Severe Duty motors are designed and built to operate under harsh environments in the industry, including but not limited to petrochemical, pulp and paper mills and waste-water treatment. Fans, compressors, pumps and conveyors are some of the many applications. These motors are design to meet or exceed the NEMA Premium® efficiency (MG1 Table 12-12) as well as the most stringent industry standards IEEE 841. A wide selection of options, among them IP56 ingress protection, encoders, brakes and blower, provide higher flexibility and reliability to a diversity of operating conditions. The construction of these motors is backed up by its 3 to 5 year warranty for SD100, and 5 year warranty for SD100 IEEE841 and SD661.

Performance Specification					
		SD100	SD100 IEEE841	SD661	SD200
HP Range	3600 RPM	1 - 400 HP		-	450-800 HP
	1800 RPM	1 - 400 HP		5 - 75 HP	400-700 HP
	1200 RPM	1 - 300 HP		7 1/2 - 50 HP	350 - 600 HP
	900 RPM	1 - 250 HP		-	-
Frame Size	140T - 500	140T-S449		180T-360T	500
Standard Voltage (3~ 60 Hz)	230V/460V (Suitable for 208V)	FS 140-250	-	-	-
	230V/460V	Up to 75 HP	-	-	-
	460V	1-800 HP	1 - 500 HP	5 - 75 HP	1-800 HP
	575V	1-800 HP	1 - 500 HP	5 - 75 HP	1-800 HP
Efficiency	NEMA Premium® (MG1-Table 12-12)	1 - 500 HP		5 - 75 HP	1 - 500 HP
	NEMA Premium® Plus (>MG1-Table 12-12)	1 - 20 HP		5 - 20 HP ²⁾	-
Service Factor	1.15 @ 40°C	FS140-500		FS 180-360	FS 500
Insulation	Non-Hygroscopic	Class F			
Temperature Rise	Class B	@ 1.0SF			
	Class F	@ 1.15SF			
Conduit Box (Oversized)	Oversized	Cast Iron			
Fan Cover		Cast Iron			
Cooling Fan	Bi-Directional	Polypropylene			
Rotor	Die Cast Aluminum	FS 140-S449		FS 180-360	FS 500
	Die Cast Copper	FS 140-250		FS 180-250 ²⁾	-
Ingress Protection	NEMA	IP55		IP56	IP55
Hazardous Location	Gas ³⁾	CL 1, Div 2 Gr. A,B,C or D Temp Code T3			
	Dust ⁴⁾	CL 2, Div 2 Gr. F & G Temp Code T4A			
Inverter Duty	Variable Torque 20:1	FS 140-500		FS 180-360	FS 500
	Constant Torque CT 4:1	FS 140-500		FS 180-360	FS 500
	Constant Torque CT 20:1 ⁵⁾	4 Pole FS140-360		4 pole FS 180-360	-
	Constant Torque CT 10:1 ⁶⁾	4 Pole FS400-445		-	-
	Constant Torque CT 6:1 ⁶⁾	4 Pole FS447		-	-
     					

1) IEEE841 Features above 500HP

2) On request

3) Class I, Zone 2, Gr IIC, as option (M22);
FS 449 and FS S449: Temperature Code T2D

4) As option (M25)

5) Standard for Copper rotor motors;
Inquire about other temperature codes

6) As option (M05 - VSD Fan)



SIMOTICS Severe Duty Motors

Frame and End Shields

The SIMOTICS Severe Duty motor, SD100, SD100IEEE841 and SD661, feature cast iron frame, end shields, and an easy-to-access, diagonally-split, oversize terminal box; the terminal box is provided with a neoprene gasket and includes a heavy-duty ground lug and non-wicking clearly and permanently marked leads. These characteristics, its high strength zinc-plated hardware, epoxy paint and stainless steel nameplate provide exceptional structural integrity and resistance to rust and corrosion, making them suitable for severe duty applications in harsh environments

Rotor and Stator Windings

A unique offset rotor bar design provides improved efficiency, while larger bars and end rings reduce resistance for lower rotor losses. Each die cast aluminum rotor assembly is dynamically balanced for extended bearing life and includes a high-strength carbon steel (C1045) shaft for maximum rotor performance.

The stator is manufactured with premium electrical C5 grade steel lamination and copper electrical magnet wire that furthers the reduction in losses.

Insulation

The proprietary Class F non-hygroscopic insulation system, NEMA Class B temperature rise, provides an extra margin of thermal life. The varnish system application ensures maximum wire penetration to provide protection from moisture, corrosion and electrical shock. This insulation system meets or exceeds NEMA MG1 2014 Part 31 making the motors suitable for variable speed drives in constant torque (4:1) and variable torque (20:1). All windings are tested for CIV.

Cooling System

A non-sparking, bi-directional fan is locked and keyed to the shaft. Its low-inertia design reduces windage losses, improves airflow, reduces noise and provides dependable cooling. Cast Iron fan covers are provided for all frames sizes.

Bearings

Single shielded bearings are used for better bearing protection against contaminants.



SIMOTICS Severe Duty Motors

SD100

SD100 (Cast Iron Frame) Rotor: Die Cast Aluminum Eff: NEMA Premium					Delivery Category:			Stock	Quick Mod	Custom Build
Power HP	Speed Rpm	NEMA Frame	Base Part Number ■ ■ ■ = digits 14,15,16	Voltage	Digits 14,15,16			Eff	Weight Lbs	
					Foot Mounted	Foot Mounted C-Face	Round Body C-Face			
					AA3	EA3**	GA3**			
					List Price \$					
1	3600	143T	1LE2321-1AA11-4 ■■■	230/460*	574	680	664	82.5%	75	
1	1800	143T	1LE2321-1AB21-4 ■■■	230/460*	537	643	627	85.5%	76	
1	1200	145T	1LE2321-1AC31-4 ■■■	230/460*	663	769	753	82.5%	77	
1	900	182T	1LE2321-1CD11-4 ■■■	230/460*	900	1054	1,032	74.0%	106	
1 1/2	3600	143T	1LE2321-1AA21-4 ■■■	230/460*	574	680	664	84.0%	70	
1 1/2	1800	145T	1LE2321-1AB31-4 ■■■	230/460*	595	701	685	86.5%	80	
1 1/2	1200	182T	1LE2321-1CC11-4 ■■■	230/460*	747	901	879	87.5%	113	
1 1/2	900	184T	1LE2321-1CD31-4 ■■■	230/460*	1,014	1,168	1,146	77.0%	119	
2	3600	145T	1LE2321-1AA31-4 ■■■	230/460*	686	792	776	85.5%	72	
2	1800	145T	1LE2321-1AB41-4 ■■■	230/460*	655	761	745	86.5%	80	
2	1200	184T	1LE2321-1CC31-4 ■■■	230/460*	835	989	967	88.5%	122	
2	900	213T	1LE2321-2AD11-4 ■■■	230/460*	1,175	1,339	1,307	82.5%	143	
3	3600	182T	1LE2321-1CA11-4 ■■■	230/460*	771	925	903	86.5%	107	
3	1800	182T	1LE2321-1CB11-4 ■■■	230/460*	726	880	858	89.5%	118	
3	1200	213T	1LE2321-2AC1-14 ■■■	230/460*	1,017	1,181	1,149	89.5%	164	
3	900	215T	1LE2321-2AD21-4 ■■■	230/460*	1,621	1,785	1,753	84.0%	158	
5	3600	184T	1LE2321-1CA31-4 ■■■	230/460*	955	1,109	1,087	88.5%	118	
5	1800	184T	1LE2321-1CB31-4 ■■■	230/460*	848	1,002	980	89.5%	124	
5	1200	215T	1LE2321-2AC21-4 ■■■	230/460*	1,433	1,597	1,565	89.5%	176	
5	900	254T	1LE2321-2BD11-4 ■■■	230/460*	2,279	2,508	2,459	85.5%	247	
7 1/2	3600	213T	1LE2321-2AA11-4 ■■■	230/460*	1,121	1,285	1,253	89.5%	160	
7 1/2	1800	213T	1LE2321-2AB11-4 ■■■	230/460*	1,117	1,281	1,249	91.7%	191	
7 1/2	1200	254T	1LE2321-2BC11-4 ■■■	230/460*	1,852	2,081	2,032	91.0%	292	
7 1/2	900	256T	1LE2321-2BD21-4 ■■■	230/460*	2,630	2,859	2,810	85.5%	279	
10	3600	215T	1LE2321-2AA21-4 ■■■	230/460*	1,349	1,513	1,481	90.2%	174	
10	1800	215T	1LE2321-2AB21-4 ■■■	230/460*	1,387	1,551	1,519	91.7%	197	
10	1200	256T	1LE2321-2BC21-4 ■■■	230/460*	2,328	2,557	2,508	91.0%	288	
10	900	284T	1LE2321-2CD11-6 ■■■	230/460	3,511	4,381	4,450	91.0%	375	
15	3600	254T	1LE2321-2BA11-4 ■■■	230/460*	1,853	2,082	2,033	91.0%	287	
15	1800	254T	1LE2321-2BB11-4 ■■■	230/460*	1,826	2,055	2,006	92.4%	289	
15	1200	284T	1LE2321-2CC11-6 ■■■	230/460	2,954	3,824	3,893	91.7%	400	
15	900	286T	1LE2321-2CD21-6 ■■■	230/460	4,569	5,439	5,508	91.0%	430	
20	3600	256T	1LE2321-2BA21-4 ■■■	230/460*	2,294	2,523	2,474	91.0%	323	
20	1800	256T	1LE2321-2BB21-4 ■■■	230/460*	2,274	2,503	2,454	93.0%	322	
20	1200	286T	1LE2321-2CC21-6 ■■■	230/460	3,598	4,468	4,537	91.7%	465	
20	900	324T	1LE2321-3AD11-6 ■■■	230/460	5,585	6,526	6,614	91.0%	567	

*Suitable for 208V; **Add 'C' after frame. Ex. 184TC; 1) CW Rotation facing opposite DE; 2) NEMA design A

Note - 'R' before the frame designates the motor has Roller bearings

NEMA Premium is a certification mark of the National Electrical Manufacturer's Association.

QuikMOD Delivery is for stocked motors only.



SIMOTICS Severe Duty Motors

SD100 (Continued)

SD100 (Cast Iron Frame) Rotor: Die Cast Aluminum Eff: NEMA Premium					Delivery Category:			Stock	Quick Mod	Custom Build
Power HP	Speed Rpm	NEMA Frame	Base Part Number ■ ■ ■ = digits 14,15,16	Voltage	Digits 14,15,16			Eff	Weight Lbs	
					Foot Mounted	Foot Mounted C-Face	Round Body C-Face			
					AA3	EA3**	GA3**			
					List Price \$					
25	3600	284TS	1LE2321-2DA11-2 ■ ■ ■	460	2,702	3,572	3,641	91.7%	415	
25	1800	284TS	1LE2321-2DB11-2 ■ ■ ■	460	2,587	3,457	3,526	93.6%	445	
25	1800	284T	1LE2321-2CB11-2 ■ ■ ■	460	2,587	3,457	3,526	93.6%	445	
25	1200	324T	1LE2321-3AC11-2 ■ ■ ■	460	4,235	5,176	5,264	93.0%	640	
25	900	326T	1LE2321-3AD21-2 ■ ■ ■	460	6,487	7,428	7,516	90.2%	600	
30	3600	286TS	1LE2321-2DA21-2 ■ ■ ■	460	3,155	4,025	4,094	91.7%	430	
30	1800	286TS	1LE2321-2DB21-2 ■ ■ ■	460	3,010	3,880	3,949	93.6%	465	
30	1800	286T	1LE2321-2CB21-2 ■ ■ ■	460	3,010	3,880	3,949	93.6%	465	
30	1200	326T	1LE2321-3AC21-2 ■ ■ ■	460	5,017	5,958	6,046	93.0%	675	
30	900	364T	1LE2321-3CD11-2 ■ ■ ■	460	7,676	8,692	8,984	91.0%	800	
40	3600	324TS	1LE2321-3BA11-2 ■ ■ ■	460	4,163	5,104	5,192	93.6%	575	
40	1800	324TS	1LE2321-3BB11-2 ■ ■ ■	460	3,998	4,939	5,027	94.1%	666	
40	1800	324T	1LE2321-3AB11-2 ■ ■ ■	460	3,998	4,939	5,027	94.1%	666	
40	1200	364T	1LE2321-3CC11-2 ■ ■ ■	460	6,803	7,819	8,111	94.1%	863	
40	900	365T	1LE2321-3CD21-2 ■ ■ ■	460	9,283	10,299	10,591	91.7%	875	
50	3600	326TS	1LE2321-3BA21-2 ■ ■ ■	460	5,384	6,325	6,413	93.6%	610	
50	1800	326TS	1LE2321-3BB21-2 ■ ■ ■	460	4,910	5,851	5,939	94.5%	700	
50	1800	326T	1LE2321-3AB21-2 ■ ■ ■	460	4,910	5,851	5,939	94.5%	700	
50	1200	365T	1LE2321-3CC21-2 ■ ■ ■	460	7,810	8,826	9,118	94.1%	900	
50	900	404T	1LE2321-4AD11-2 ■ ■ ■	460	11,091	12,352	12,775	91.7%	1135	
60	3600	364TS	1LE2321-3DA11-2 ■ ■ ■	460	7,083	8,099	8,391	93.6%	717	
60	1800	364TS	1LE2321-3DB11-2 ■ ■ ■	460	7,043	8,059	8,351	95.0%	930	
60	1800	364T	1LE2321-3CB11-2 ■ ■ ■	460	7,043	8,059	8,351	95.0%	930	
60	1200	404T	1LE2321-4AC11-2 ■ ■ ■	460	9,150	10,411	10,834	94.5%	1100	
60	900	405T	1LE2321-4AD21-2 ■ ■ ■	460	12,668	13,929	14,352	91.7%	1300	
75	3600	365TS	1LE2321-3DA21-2 ■ ■ ■	460	8,894	9,910	10,202	94.1%	815	
75	1800	365TS	1LE2321-3DB21-2 ■ ■ ■	460	8,928	9,944	10,236	95.4%	1000	
75	1800	365T	1LE2321-3CB21-2 ■ ■ ■	460	8,928	9,944	10,236	95.4%	1000	
75	1200	405T	1LE2321-4AC21-2 ■ ■ ■	460	10,772	12,033	12,456	94.5%	1150	
75	900	R444T	1LE2321-4CD11-2 ■ ■ ■	460	17,302	--	--	93.0%	1625	
75	900	444TS	1LE2321-4DD11-2 ■ ■ ■	460	16,694	18,187	18,997	93.0%	1625	
75	900	440T	1LE2321-4ED11-2 ■ ■ ■	460	16,694	18,187	18,997	93.0%	1625	

*Suitable for 208V; **Add 'C' after frame. Ex. 184TC; 1) CW Rotation facing opposite DE; 2) NEMA design A

Note - 'R' before the frame designates the motor has Roller bearings

NEMA Premium is a certification mark of the National Electrical Manufacturer's Association.

QuikMOD Delivery is for stocked motors only.



SIMOTICS Severe Duty Motors

SD100 (Continued)

SD100 (Cast Iron Frame) Rotor: Die Cast Aluminum Eff: NEMA Premium					Delivery Category:			Stock	Quick Mod	Custom Build
Power HP	Speed Rpm	NEMA Frame	Base Part Number ■ ■ ■ = digits 14,15,16	Voltage	Digits 14,15,16			Eff	Weight Lbs	
					Foot Mounted	Foot Mounted C-Face	Round Body C-Face			
					AA3	EA3**	GA3**			
					List Price \$					
100	3600	405TS	1LE2321-4BA21-2 ■■■	460	11,919	13,180	13,603	94.1%	1100	
100	1800	405TS	1LE2321-4BB21-2 ■■■	460	11,032	12,293	12,716	95.4%	1160	
100	1800	405T	1LE2321-4AB21-2 ■■■	460	11,032	12,293	12,716	95.4%	1160	
100	1200	444TS	1LE2321-4DC11-2 ■■■	460	14,724	16,217	17,027	95.0%	1545	
100	1200	R444T	1LE2321-4CC11-2 ■■■	460	15,332	--	--	95.0%	1545	
100	1200	444T	1LE2321-4EC11-2 ■■■	460	14,724	16,217	17,027	95.0%	1545	
100	900	R445T	1LE2321-4CD21-2 ■■■	460	21,249	--	--	94.1%	1900	
100	900	445T	1LE2321-4ED21-2 ■■■	460	20,641	22,134	22,944	94.1%	1900	
100	900	445TS	1LE2321-4DD21-2 ■■■	460	20,641	22,134	22,944	94.1%	1900	
125	3600	444TS	1LE2321-4DA11-2 ■■■	460	15,574	17,067	17,877	95.0%	1454	
125	1800	444TS	1LE2321-4DB11-2 ■■■	460	14,518	16,011	16,821	95.4%	1600	
125	1800	R444T	1LE2321-4CB11-2 ■■■	460	15,126	--	--	95.4%	1600	
125	1800	444T	1LE2321-4EB11-2 ■■■	460	14,518	16,011	16,821	95.4%	1600	
125	1200	445TS	1LE2321-4DC21-2 ■■■	460	18,079	19,572	20,382	95.0%	1720	
125	1200	R445T	1LE2321-4CC21-2 ■■■	460	18,687	--	--	95.0%	1720	
125	1200	445T	1LE2321-4EC21-2 ■■■	460	18,079	19,572	20,382	95.0%	1720	
125	900	R447T	1LE2321-4CD31-2 ■■■	460	22,505	--	--	93.6%	2280	
125	900	447T	1LE2321-4ED31-2 ■■■	460	21,897	23,390	24,200	93.6%	2280	
125	900	447TS	1LE2321-4DD31-2 ■■■	460	21,897	23,390	24,200	93.6%	2280	
150	3600	445TS	1LE2321-4DA21-2 ■■■	460	18,709	20,202	21,012	95.0%	1615	
150	1800	445TS	1LE2321-4DB21-2 ■■■	460	16,878	18,371	19,181	95.8%	1710	
150	1800	R445T	1LE2321-4CB21-2 ■■■	460	17,486	--	--	95.8%	1710	
150	1800	445T	1LE2321-4EB21-2 ■■■	460	16,878	18,371	19,181	95.8%	1710	
150	1200	447TS	1LE2321-4DC31-2 ■■■	460	20,228	21,721	22,531	95.8%	1995	
150	1200	R447T	1LE2321-4CC31-2 ■■■	460	20,836	--	--	95.8%	1995	
150	1200	447T	1LE2321-4EC31-2 ■■■	460	20,228	21,721	22,531	95.8%	1995	
150	900	R447T	1LE2321-4CD41-2 ■■■	460	28,572	--	--	94.1%	2280	
150	900	447T	1LE2321-4ED41-2 ■■■	460	27,964	29,457	30,267	94.1%	2280	
200	3600	447TS	1LE2321-4DA31-2 ■■■	460	23,666	25,159	25,969	95.4%	1890	
200	1800	447TS	1LE2321-4DB31-2 ■■■	460	20,529	22,022	22,832	96.2%	2035	
200	1800	R447T	1LE2321-4CB31-2 ■■■	460	21,137	--	--	96.2%	2035	
200	1800	447T	1LE2321-4EB31-2 ■■■	460	20,529	22,022	22,832	96.2%	2035	
200	1200	449TS	1LE2321-4DC51-2 ■■■	460	24,761	26,254	27,064	95.8%	2425	
200	1200	R449T	1LE2321-4CC51-2 ■■■	460	25,369	--	--	95.8%	2425	
200	1200	449T	1LE2321-4EC51-2 ■■■	460	24,761	26,254	27,064	95.8%	2425	
200	900	RS449LS	1LE2321-4FD11-2 ■■■	460	34,838	--	--	94.5%	3200	
200	900	S449SS	1LE2321-4GD11-2 ■■■	460	34,230	CF	--	94.5%	3200	

*Suitable for 208V; **Add 'C' after frame. Ex. 184TC; 1) CW Rotation facing opposite DE; 2) NEMA design A

Note - 'R' before the frame designates the motor has Roller bearings

NEMA Premium is a certification mark of the National Electrical Manufacturer's Association.

QuikMOD Delivery is for stocked motors only.



SIMOTICS Severe Duty Motors

SD100 (Continued)

SD100 (Cast Iron Frame) Rotor: Die Cast Aluminum Eff: NEMA Premium					Delivery Category:			Stock	Eff		Weight Lbs	
					Quick Mod			Custom Build				
Power HP	Speed Rpm	NEMA Frame	Base Part Number ■ ■ ■ = digits 14,15,16	Voltage	Digits 14,15,16			List Price \$				
					Foot Mounted	Foot Mounted C-Face	Round Body C-Face					
					AA3	EA3**	GA3**					
250	3600	449TS	1LE2321-4DA51-2 ■ ■ ■	460	29,849	31,342	32,152	95.8%	2272			
250	1800	449TS ²⁾	1LE2321-4DB51-2 ■ ■ ■	460	25,755	27,248	28,058	96.2%	2425			
250	1800	R449T ²⁾	1LE2321-4CB51-2 ■ ■ ■	460	26,363	--	--	96.2%	2425			
250	1800	449T ²⁾	1LE2321-4EB51-2 ■ ■ ■	460	25,755	27,248	28,058	96.2%	2425			
250	1200	449TS ²⁾	1LE2321-4DC61-2 ■ ■ ■	460	26,944	28,437	29,247	95.8%	2390			
250	1200	R449T ²⁾	1LE2321-4CC61-2 ■ ■ ■	460	27,552	--	--	95.8%	2390			
250	1200	449T ²⁾	1LE2321-4EC61-2 ■ ■ ■	460	26,944	28,437	29,247	95.8%	2390			
250	900	RS449LS	1LE2321-4FD21-2 ■ ■ ■	460	41,045	--	--	94.5%	3316			
300	3600	449TS	1LE2321-4DA61-2 ■ ■ ■	460	40,858	42,351	43,161	95.8%	2200			
300	1800	449TS ²⁾	1LE2321-4DB61-2 ■ ■ ■	460	30,036	31,529	32,339	96.2%	3130			
300	1800	R449T ²⁾	1LE2321-4CB61-2 ■ ■ ■	460	30,644	--	--	96.2%	3130			
300	1800	449T ²⁾	1LE2321-4EB61-2 ■ ■ ■	460	30,036	31,529	32,339	96.2%	3130			
300	1200	RS449LS ²⁾	1LE2321-4FC11-2 ■ ■ ■	460	48,251	--	--	95.8%	3240			
350	3600	S449SS ¹⁾	1LE2321-4GA11-2 ■ ■ ■	460	41,992	CF	--	95.8%	2890			
350	1800	S449SS	1LE2321-4GB21-2 ■ ■ ■	460	39,003	CF	--	96.2%	3190			
350	1800	RS449LS	1LE2321-4FB21-2 ■ ■ ■	460	39,611	--	--	96.2%	3190			
400	3600	S449SS ¹⁾	1LE2321-4GA31-2 ■ ■ ■	460	52,365	CF	--	95.8%	3065			
400	1800	S449SS	1LE2321-4GB31-2 ■ ■ ■	460	48,649	CF	--	96.2%	3240			
400	1800	RS449LS	1LE2321-4FB31-2 ■ ■ ■	460	49,257	--	--	96.2%	3240			

*Suitable for 208V; **Add 'C' after frame. Ex. 184TC; 1) CW Rotation facing opposite DE; 2) NEMA design A

Note - 'R' before the frame designates the motor has Roller bearings

NEMA Premium is a certification mark of the National Electrical Manufacturer's Association.

QuikMOD Delivery is for stocked motors only.



SIMOTICS Severe Duty Motors

SD100 Cu

SD100 (Cast Iron Frame) Rotor: Die Cast Copper Eff: NEMA Premium					Delivery Category:			Stock	Quick Mod	Custom Build
Power HP	Speed Rpm	NEMA Frame	Base Part Number ■ ■ ■ = digits 14,15,16	Voltage	Digits 14,15,16			Eff	Weight Lbs	
					Foot Mounted	Foot Mounted C-Face	Round Body C-Face			
					AA3	EA3**	GA3**			
					List Price \$					
1	1800	143T	1LE2311-1AB21-4 ■ ■ ■	230/460*	627	733	717	82.5%	75	
1	1200	145T	1LE2311-1AC31-4 ■ ■ ■	230/460*	780	886	870	85.5%	76	
1 1/2	3600	143T	1LE2311-1AA21-4 ■ ■ ■	230/460*	671	777	761	82.5%	77	
1 1/2	1800	145T	1LE2311-1AB31-4 ■ ■ ■	230/460*	695	801	785	74.0%	106	
2	3600	145T	1LE2311-1AA31-4 ■ ■ ■	230/460*	802	908	892	84.0%	70	
2	1800	145T	1LE2311-1AB41-4 ■ ■ ■	230/460*	765	871	855	86.5%	80	
3	3600	182T	1LE2311-1CA11-4 ■ ■ ■	230/460*	903	1,057	1,035	87.5%	113	
3	1800	182T	1LE2311-1CB11-4 ■ ■ ■	230/460*	847	1001	979	77.0%	119	
3	1200	213T	1LE2311-2AC11-4 ■ ■ ■	230/460*	1,198	1362	1,330	85.5%	72	
5	3600	184T	1LE2311-1CA31-4 ■ ■ ■	230/460*	1,117	1271	1,249	86.5%	80	
5	1800	184T	1LE2311-1CB31-4 ■ ■ ■	230/460*	990	1144	1,122	88.5%	122	
5	1200	215T	1LE2311-2AC21-4 ■ ■ ■	230/460*	1,688	1,852	1,820	82.5%	143	
7 1/2	3600	213T	1LE2311-2AA11-4 ■ ■ ■	230/460*	1,312	1,476	1,444	86.5%	107	
7 1/2	1800	213T	1LE2311-2AB11-4 ■ ■ ■	230/460*	1,304	1,468	1,436	89.5%	118	
7 1/2	1200	254T	1LE2311-2BC11-4 ■ ■ ■	230/460*	2,181	2,410	2,361	89.5%	164	
10	3600	215T	1LE2311-2AA21-4 ■ ■ ■	230/460*	1,579	1,743	1,711	84.0%	158	
10	1800	215T	1LE2311-2AB21-4 ■ ■ ■	230/460*	1,617	1,781	1,749	88.5%	118	
10	1200	256T	1LE2311-2BC21-4 ■ ■ ■	230/460*	2,742	2,971	2,922	89.5%	124	
15	3600	254T	1LE2311-2BA11-4 ■ ■ ■	230/460*	2,168	2,397	2,348	89.5%	176	
15	1800	254T	1LE2311-2BB11-4 ■ ■ ■	230/460*	2,131	2,360	2,311	85.5%	247	
20	3600	256T	1LE2311-2BA21-4 ■ ■ ■	230/460*	2,684	2,913	2,864	89.5%	160	
20	1800	256T	1LE2311-2BB21-4 ■ ■ ■	230/460*	2,653	2,882	2,833	91.7%	191	

*Suitable for 208V

**Add 'C' after frame. Ex. 184TC;

NEMA Premium is a certification mark of the National Electrical Manufacturer's Association.

QuikMOD Delivery is for stocked motors only.

Introduction

Special Features

Motor Selection and Pricing

Special Features Details

Typical Performance Details

General Dimensions

MV449 Frame

Indexes



SIMOTICS Severe Duty Motors

SD100 575

SD100 (Cast Iron Frame) Rotor: Die Cast Aluminum Eff: NEMA Premium					Delivery Category:			Stock	Quick Mod	Custom Build
Power HP	Speed Rpm	NEMA Frame	Base Part Number ■ ■ ■ = digits 14,15,16	Voltage	Digits 14,15,16			Eff	Weight Lbs	
					Foot Mounted	Foot Mounted C-Face	Round Body C-Face			
					AA3	EA3**	GA3**			
					List Price \$					
1	3600	143T	1LE2321-1AA11-3 ■ ■ ■	575	574	680	664	82.5%	75	
1	1800	143T	1LE2321-1AB21-3 ■ ■ ■	575	537	643	627	85.5%	76	
1	1200	145T	1LE2321-1AC31-3 ■ ■ ■	575	663	769	753	82.5%	77	
1	900	182T	1LE2321-1CD11-3 ■ ■ ■	575	900	1054	1,032	74.0%	106	
1 1/2	3600	143T	1LE2321-1AA21-3 ■ ■ ■	575	574	680	664	84.0%	70	
1 1/2	1800	145T	1LE2321-1AB31-3 ■ ■ ■	575	595	701	685	86.5%	80	
1 1/2	1200	182T	1LE2321-1CC11-3 ■ ■ ■	575	747	901	879	87.5%	113	
1 1/2	900	184T	1LE2321-1CD31-3 ■ ■ ■	575	1,014	1168	1,146	77.0%	119	
2	3600	145T	1LE2321-1AA31-3 ■ ■ ■	575	686	792	776	85.5%	72	
2	1800	145T	1LE2321-1AB41-3 ■ ■ ■	575	655	761	745	86.5%	80	
2	1200	184T	1LE2321-1CC31-3 ■ ■ ■	575	835	989	967	88.5%	122	
2	900	213T	1LE2321-2AD11-3 ■ ■ ■	575	1,175	1,339	1,307	82.5%	143	
3	3600	182T	1LE2321-1CA11-3 ■ ■ ■	575	771	925	903	86.5%	107	
3	1800	182T	1LE2321-1CB11-3 ■ ■ ■	575	726	880	858	89.5%	118	
3	1200	213T	1LE2321-2AC11-3 ■ ■ ■	575	1,017	1,181	1,149	89.5%	164	
3	900	215T	1LE2321-2AD21-3 ■ ■ ■	575	1,621	1,785	1,753	84.0%	158	
5	3600	184T	1LE2321-1CA31-3 ■ ■ ■	575	955	1,109	1,087	88.5%	118	
5	1800	184T	1LE2321-1CB31-3 ■ ■ ■	575	848	1,002	980	89.5%	124	
5	1200	215T	1LE2321-2AC21-3 ■ ■ ■	575	1,433	1,597	1,565	89.5%	176	
5	900	254T	1LE2321-2BD11-3 ■ ■ ■	575	2,279	2,508	2,459	85.5%	247	
7 1/2	3600	213T	1LE2321-2AA11-3 ■ ■ ■	575	1,121	1,285	1,253	89.5%	160	
7 1/2	1800	213T	1LE2321-2AB11-3 ■ ■ ■	575	1,117	1,281	1,249	91.7%	191	
7 1/2	1200	254T	1LE2321-2BC11-3 ■ ■ ■	575	1,852	2,081	2,032	91.0%	292	
7 1/2	900	256T	1LE2321-2BD21-3 ■ ■ ■	575	2,630	2,859	2,810	85.5%	279	
10	3600	215T	1LE2321-2AA21-3 ■ ■ ■	575	1,349	1,513	1,481	90.2%	174	
10	1800	215T	1LE2321-2AB21-3 ■ ■ ■	575	1,387	1,551	1,519	91.7%	197	
10	1200	256T	1LE2321-2BC21-3 ■ ■ ■	575	2,328	2,557	2,508	91.0%	288	
10	900	284T	1LE2321-2CD11-3 ■ ■ ■	575	3,511	4,381	4,450	91.0%	375	
15	3600	254T	1LE2321-2BA11-3 ■ ■ ■	575	1,853	2,082	2,033	91.0%	287	
15	1800	254T	1LE2321-2BB11-3 ■ ■ ■	575	1,826	2,055	2,006	92.4%	289	
15	1200	284T	1LE2321-2CC11-3 ■ ■ ■	575	2,954	3,824	3,893	91.7%	400	
15	900	286T	1LE2321-2CD21-3 ■ ■ ■	575	4,569	5,439	5,508	91.0%	430	
20	3600	256T	1LE2321-2BA21-3 ■ ■ ■	575	2,294	2,523	2,474	91.0%	323	
20	1800	256T	1LE2321-2BB21-3 ■ ■ ■	575	2,274	2,503	2,454	93.0%	322	
20	1200	286T	1LE2321-2CC21-3 ■ ■ ■	575	3,598	4,468	4,537	91.7%	465	
20	900	324T	1LE2321-3AD11-3 ■ ■ ■	575	5,585	6,526	6,614	91.0%	567	

**Add 'C' after frame. Ex. 184TC; 1) CW Rotation facing opposite DE; 2) NEMA design A
 Note - 'R' before the frame designates the motor has Roller bearings
 NEMA Premium is a certification mark of the National Electrical Manufacturer's Association.
 QuikMOD Delivery is for stocked motors only.



SIMOTICS Severe Duty Motors

SD100 575 (Continued)

SD100 (Cast Iron Frame) Rotor: Die Cast Aluminum Eff: NEMA Premium					Delivery Category:			Stock		
								Quick Mod		
								Custom Build		
Power HP	Speed Rpm	NEMA Frame	Base Part Number ■ ■ ■ = digits 14,15,16	Voltage	Digits 14,15,16			Eff	Weight Lbs	
					Foot Mounted	Foot Mounted C-Face	Round Body C-Face			
					AA3	EA3**	GA3**			
					List Price \$					
25	3600	284TS	1LE2321-2DA11-3 ■ ■ ■	575	2,702	3,572	3,641	91.7%	415	
25	1800	284TS	1LE2321-2DB11-3 ■ ■ ■	575	2,587	3,457	3,526	93.6%	445	
25	1800	284T	1LE2321-2CB11-3 ■ ■ ■	575	2,587	3,457	3,526	93.6%	445	
25	1200	324T	1LE2321-3AC11-3 ■ ■ ■	575	4,235	5,176	5,264	93.0%	640	
25	900	326T	1LE2321-3AD21-3 ■ ■ ■	575	6,487	7,428	7,516	90.2%	600	
30	3600	286TS	1LE2321-2DA21-3 ■ ■ ■	575	3,155	4,025	4,094	91.7%	430	
30	1800	286TS	1LE2321-2DB21-3 ■ ■ ■	575	3,010	3,880	3,949	93.6%	465	
30	1800	286T	1LE2321-2CB21-3 ■ ■ ■	575	3,010	3,880	3,949	93.6%	465	
30	1200	326T	1LE2321-3AC21-3 ■ ■ ■	575	5,017	5,958	6,046	93.0%	675	
30	900	364T	1LE2321-3CD11-3 ■ ■ ■	575	7,676	8,692	8,984	91.0%	800	
40	3600	324TS	1LE2321-3BA11-3 ■ ■ ■	575	4,163	5,104	5,192	93.6%	575	
40	1800	324TS	1LE2321-3BB11-3 ■ ■ ■	575	3,998	4,939	5,027	94.1%	666	
40	1800	324T	1LE2321-3AB11-3 ■ ■ ■	575	3,998	4,939	5,027	94.1%	666	
40	1200	364T	1LE2321-3CC11-3 ■ ■ ■	575	6,803	7,819	8,111	94.1%	863	
40	900	365T	1LE2321-3CD21-3 ■ ■ ■	575	9,283	10,299	10,591	91.7%	875	
50	3600	326TS	1LE2321-3BA21-3 ■ ■ ■	575	5,384	6,325	6,413	93.6%	610	
50	1800	326TS	1LE2321-3BB21-3 ■ ■ ■	575	4,910	5,851	5,939	94.5%	700	
50	1800	326T	1LE2321-3AB21-3 ■ ■ ■	575	4,910	5,851	5,939	94.5%	700	
50	1200	365T	1LE2321-3CC21-3 ■ ■ ■	575	7,810	8,826	9,118	94.1%	900	
50	900	404T	1LE2321-4AD11-3 ■ ■ ■	575	11,091	12,352	12,775	91.7%	1135	
60	3600	364TS	1LE2321-3DA11-3 ■ ■ ■	575	7,083	8,099	8,391	93.6%	717	
60	1800	364TS	1LE2321-3DB11-3 ■ ■ ■	575	7,043	8,059	8,351	95.0%	930	
60	1800	364T	1LE2321-3CB11-3 ■ ■ ■	575	7,043	8,059	8,351	95.0%	930	
60	1200	404T	1LE2321-4AC11-3 ■ ■ ■	575	9,150	10,411	10,834	94.5%	1100	
60	900	405T	1LE2321-4AD21-3 ■ ■ ■	575	12,668	13,929	14,352	91.7%	1300	
75	3600	365TS	1LE2321-3DA21-3 ■ ■ ■	575	8,894	9,910	10,202	94.1%	815	
75	1800	365TS	1LE2321-3DB21-3 ■ ■ ■	575	8,928	9,944	10,236	95.4%	1000	
75	1800	365T	1LE2321-3CB21-3 ■ ■ ■	575	8,928	9,944	10,236	95.4%	1000	
75	1200	405T	1LE2321-4AC21-3 ■ ■ ■	575	10,772	12,033	12,456	94.5%	1150	
75	900	R444T	1LE2321-4CD11-3 ■ ■ ■	575	17,302	N/A	N/A	93.0%	1625	
75	900	444T	1LE2321-4ED11-3 ■ ■ ■	575	16,694	18,187	18,997	93.0%	1625	
75	900	444TS	1LE2321-4DD11-3 ■ ■ ■	575	16,694	18,187	18,997	93.0%	1625	

**Add 'C' after frame. Ex. 184TC; 1) CW Rotation facing opposite DE; 2) NEMA design A
 Note - 'R' before the frame designates the motor has Roller bearings
 NEMA Premium is a certification mark of the National Electrical Manufacturer's Association.
 QuikMOD Delivery is for stocked motors only.



SIMOTICS Severe Duty Motors

SD100 575 (Continued)

SD100 (Cast Iron Frame) Rotor: Die Cast Aluminum Eff: NEMA Premium					Delivery Category:			Stock	Quick Mod	Custom Build
Power HP	Speed Rpm	NEMA Frame	Base Part Number ■ ■ ■ = digits 14,15,16	Voltage	Digits 14,15,16			Eff	Weight Lbs	
					Foot Mounted	Foot Mounted C-Face	Round Body C-Face			
					AA3	EA3**	GA3**			
					List Price \$					
100	3600	405TS	1LE2321-4BA21-3 ■■■	575	11,919	13,180	13,603	94.1%	1100	
100	1800	405TS	1LE2321-4BB21-3 ■■■	575	11,032	12,293	12,716	95.4%	1160	
100	1800	405T	1LE2321-4AB21-3 ■■■	575	11,032	12,293	12,716	95.4%	1160	
100	1200	444TS	1LE2321-4DC11-3 ■■■	575	14,724	16,217	17,027	95.0%	1545	
100	1200	R444T	1LE2321-4CC11-3 ■■■	575	15,332	N/A	N/A	95.0%	1545	
100	1200	444T	1LE2321-4EC11-3 ■■■	575	14,724	16,217	17,027	95.0%	1545	
100	900	R445T	1LE2321-4CD21-3 ■■■	575	21,249	N/A	N/A	94.1%	1900	
100	900	445T	1LE2321-4ED21-3 ■■■	575	20,641	22,134	22,944	94.1%	1900	
100	900	445TS	1LE2321-4DD21-3 ■■■	575	20,641	22,134	22,944	94.1%	1900	
125	3600	444TS	1LE2321-4DA11-3 ■■■	575	15,574	17,067	17,877	95.0%	1454	
125	1800	444TS	1LE2321-4DB11-3 ■■■	575	14,518	16,011	16,821	95.4%	1600	
125	1800	R444T	1LE2321-4CB11-3 ■■■	575	15,126	N/A	N/A	95.4%	1600	
125	1800	444T	1LE2321-4EB11-3 ■■■	575	14,518	16,011	16,821	95.4%	1600	
125	1200	445TS	1LE2321-4DC21-3 ■■■	575	18,079	19,572	20,382	95.0%	1720	
125	1200	R445T	1LE2321-4CC21-3 ■■■	575	18,687	N/A	N/A	95.0%	1720	
125	1200	445T	1LE2321-4EC21-3 ■■■	575	18,079	19,572	20,382	95.0%	1720	
125	900	R447T	1LE2321-4CD31-3 ■■■	575	22,505	N/A	N/A	93.6%	2280	
125	900	447T	1LE2321-4ED31-3 ■■■	575	21,897	23,390	24,200	93.6%	2280	
125	900	447TS	1LE2321-4DD31-3 ■■■	575	21,897	23,390	24,200	93.6%	2280	
150	3600	445TS	1LE2321-4DA21-3 ■■■	575	18,709	20,202	21,012	95.0%	1615	
150	1800	445TS	1LE2321-4DB21-3 ■■■	575	16,878	18,371	19,181	95.8%	1710	
150	1800	R445T	1LE2321-4CB21-3 ■■■	575	17,486	N/A	N/A	95.8%	1710	
150	1800	445T	1LE2321-4EB21-3 ■■■	575	16,878	18,371	19,181	95.8%	1710	
150	1200	447TS	1LE2321-4DC31-3 ■■■	575	20,228	21,721	22,531	95.8%	1995	
150	1200	R447T	1LE2321-4CC31-3 ■■■	575	20,836	N/A	N/A	95.8%	1995	
150	1200	447T	1LE2321-4EC31-3 ■■■	575	20,228	21,721	22,531	95.8%	1995	
150	900	R447T	1LE2321-4CD41-3 ■■■	575	28,572	N/A	N/A	94.1%	2280	
150	900	447T	1LE2321-4ED41-3 ■■■	575	27,964	29,457	30,267	94.1%	2280	
150	900	447TS	1LE2321-4DD41-3 ■■■	575	27,964	29,457	30,267	94.1%	2280	
200	3600	447TS	1LE2321-4DA31-3 ■■■	575	23,666	25,159	25,969	95.4%	1890	
200	1800	447TS	1LE2321-4DB31-3 ■■■	575	20,529	22,022	22,832	96.2%	2035	
200	1800	R447T	1LE2321-4CB31-3 ■■■	575	21,137	N/A	N/A	96.2%	2035	
200	1800	447T	1LE2321-4EB31-3 ■■■	575	20,529	22,022	22,832	96.2%	2035	
200	1200	449TS	1LE2321-4DC51-3 ■■■	575	24,761	26,254	27,064	95.8%	2425	
200	1200	R449T	1LE2321-4CC51-3 ■■■	575	25,369	N/A	N/A	95.8%	2425	
200	1200	449T	1LE2321-4EC51-3 ■■■	575	24,761	26,254	27,064	95.8%	2425	
200	900	RS449LS	1LE2321-4FD11-3 ■■■	575	34,838	N/A	N/A	94.5%	3200	
200	900	S449SS	1LE2321-4GD11-3 ■■■	575	34,230	CF	CF	94.5%	3200	

**Add 'C' after frame. Ex. 184TC; 1) CW Rotation facing opposite DE; 2) NEMA design A

Note - 'R' before the frame designates the motor has Roller bearings

NEMA Premium is a certification mark of the National Electrical Manufacturer's Association.

QuikMOD Delivery is for stocked motors only.



SIMOTICS Severe Duty Motors

SD100 575 (Continued)

SD100 (Cast Iron Frame) Rotor: Die Cast Aluminum Eff: NEMA Premium					Delivery Category:			Stock	Quick Mod	Custom Build
Power HP	Speed Rpm	NEMA Frame	Base Part Number ■ ■ ■ = digits 14,15,16	Voltage	Digits 14,15,16			Eff	Weight Lbs	
					Foot Mounted	Foot Mounted C-Face	Round Body C-Face			
					AA3	EA3**	GA3**			
					List Price \$					
250	3600	449TS	1LE2321-4DA51-3 ■ ■ ■	575	29,849	31,342	32,152	95.8%	2272	
250	1800	449TS ²⁾	1LE2321-4DB51-3 ■ ■ ■	575	25,755	27,248	28,058	96.2%	2425	
250	1800	R449T ²⁾	1LE2321-4CB51-3 ■ ■ ■	575	26,363	N/A	N/A	96.2%	2425	
250	1800	449T ²⁾	1LE2321-4EB51-3 ■ ■ ■	575	25,755	27,248	28,058	96.2%	2425	
250	1200	449TS ²⁾	1LE2321-4DC61-3 ■ ■ ■	575	26,944	28,437	29,247	95.8%	2390	
250	1200	R449T ²⁾	1LE2321-4CC61-3 ■ ■ ■	575	27,552	N/A	N/A	95.8%	2390	
250	1200	449T ²⁾	1LE2321-4EC61-3 ■ ■ ■	575	26,944	28,437	29,247	95.8%	2390	
250	900	RS449LS	1LE2321-4FD21-3 ■ ■ ■	575	41,045	N/A	N/A	94.5%	3316	
300	3600	449TS	1LE2321-4DA61-3 ■ ■ ■	575	40,858	42,351	43,161	95.8%	2200	
300	1800	449TS ²⁾	1LE2321-4DB61-3 ■ ■ ■	575	30,036	31,529	32,339	96.2%	3130	
300	1800	R449T ²⁾	1LE2321-4CB61-3 ■ ■ ■	575	30,644	N/A	N/A	96.2%	3130	
300	1800	449T ²⁾	1LE2321-4EB61-3 ■ ■ ■	575	30,036	31,529	32,339	96.2%	3130	
300	1200	RS449LS ²⁾	1LE2321-4FC11-3 ■ ■ ■	575	48,255	N/A	N/A	95.8%	3240	
350	3600	S449SS ¹⁾	1LE2321-4GA11-3 ■ ■ ■	575	41,992	CF	CF	95.8%	2890	
350	1800	S449SS	1LE2321-4GB21-3 ■ ■ ■	575	39,003	CF	CF	96.2%	3190	
350	1800	RS449LS	1LE2321-4FB21-3 ■ ■ ■	575	39,611	N/A	N/A	96.2%	3190	
400	3600	S449SS ¹⁾	1LE2321-4GA31-3 ■ ■ ■	575	52,365	CF	CF	95.8%	3065	
400	1800	S449SS	1LE2321-4GB31-3 ■ ■ ■	575	48,649	CF	CF	96.2%	3240	
400	1800	RS449LS	1LE2321-4FB31-3 ■ ■ ■	575	49,257	N/A	N/A	96.2%	3240	

**Add 'C' after frame. Ex. 184TC; 1) CW Rotation facing opposite DE; 2) NEMA design A
 Note - 'R' before the frame designates the motor has Roller bearings
 NEMA Premium is a certification mark of the National Electrical Manufacturer's Association.
 QuikMOD Delivery is for stocked motors only.



SIMOTICS Severe Duty Motors

SD100 IEEE

SD100 IEEE841 (Cast Iron Frame) Rotor: Die Cast Aluminum Eff: NEMA Premium					Delivery Category:			Stock	Quick Mod	Custom Build
Power HP	Speed Rpm	NEMA Frame	Base Part Number ■ ■ ■ = digits 14,15,16	Voltage	Digits 14,15,16			Eff	Weight Lbs	
					Foot Mounted	Foot Mounted C-Face	Round Body C-Face			
					AA3	EA3**	GA3**			
					List Price \$					
1	3600	143T	1LE2421-1AA11-2 ■■■	460	787	893	877	82.5%	75	
1	1800	143T	1LE2421-1AB21-2 ■■■	460	762	868	852	85.5%	76	
1	1200	145T	1LE2421-1AC31-2 ■■■	460	898	1004	988	82.5%	77	
1	900	182T	1LE2421-1CD11-2 ■■■	460	1,457	1611	1,589	81.5%	106	
1 1/2	3600	143T	1LE2421-1AA21-2 ■■■	460	788	894	878	84.0%	70	
1 1/2	1800	145T	1LE2421-1AB31-2 ■■■	460	822	928	912	86.5%	80	
1 1/2	1200	182T	1LE2421-1CC11-2 ■■■	460	1,006	1,160	1,138	87.5%	113	
1 1/2	900	184T	1LE2421-1CD31-2 ■■■	460	1,719	1873	1,851	82.5%	119	
2	3600	145T	1LE2421-1AA31-2 ■■■	460	904	1010	994	85.5%	72	
2	1800	145T	1LE2421-1AB41-2 ■■■	460	878	984	968	86.5%	80	
2	1200	184T	1LE2421-1CC31-2 ■■■	460	1,071	1225	1,203	88.5%	122	
2	900	213T	1LE2421-2AD11-2 ■■■	460	2,023	2,187	2,155	84.0%	145	
3	3600	182T	1LE2421-1CA11-2 ■■■	460	947	1,101	1,079	86.5%	107	
3	1800	182T	1LE2421-1CB11-2 ■■■	460	907	1,061	1,039	89.5%	118	
3	1200	213T	1LE2421-2AC11-2 ■■■	460	1,350	1,514	1,482	89.5%	164	
3	900	215T	1LE2421-2AD21-2 ■■■	460	2,565	2,729	2,697	85.5%	160	
5	3600	184T	1LE2421-1CA31-2 ■■■	460	1,159	1,313	1,291	88.5%	118	
5	1800	184T	1LE2421-1CB31-2 ■■■	460	1,039	1,193	1,171	89.5%	124	
5	1200	215T	1LE2421-2AC21-2 ■■■	460	1,787	1,951	1,919	89.5%	176	
5	900	254T	1LE2421-2BD11-2 ■■■	460	3,428	3,657	3,608	86.5%	247	
7 1/2	3600	213T	1LE2421-2AA11-2 ■■■	460	1,421	1,585	1,553	89.5%	160	
7 1/2	1800	213T	1LE2421-2AB11-2 ■■■	460	1,380	1,544	1,512	91.7%	191	
7 1/2	1200	254T	1LE2421-2BC11-2 ■■■	460	2,284	2,513	2,464	91.0%	292	
7 1/2	900	256T	1LE2421-2BD21-2 ■■■	460	4,297	4,526	4,477	87.5%	279	
10	3600	215T	1LE2421-2AA21-2 ■■■	460	1,634	1,798	1,766	90.2%	174	
10	1800	215T	1LE2421-2AB21-2 ■■■	460	1,652	1,816	1,784	91.7%	197	
10	1200	256T	1LE2421-2BC21-2 ■■■	460	2,840	3,069	3,020	91.0%	288	
10	900	284T	1LE2421-2CD11-2 ■■■	460	4,398	5,268	5,337	90.2%	362	
15	3600	254T	1LE2421-2BA11-2 ■■■	460	2,216	2,445	2,396	91.0%	287	
15	1800	254T	1LE2421-2BB11-2 ■■■	460	2,177	2,406	2,357	92.4%	289	
15	1200	284T	1LE2421-2CC11-2 ■■■	460	3,541	4,411	4,480	91.7%	400	
15	900	286T	1LE2421-2CD21-2 ■■■	460	5,623	6,493	6,562	90.2%	420	
20	3600	256T	1LE2421-2BA21-2 ■■■	460	2,720	2,949	2,900	91.0%	323	
20	1800	256T	1LE2421-2BB21-2 ■■■	460	2,806	3,035	2,986	93.0%	322	
20	1200	286T	1LE2421-2CC21-2 ■■■	460	4,316	5,186	5,255	91.7%	465	
20	900	324T	1LE2421-3AD11-2 ■■■	460	6,875	7,816	7,904	91.0%	570	

**Add 'C' after frame. Ex. 184TC; 1) CW Rotation facing opposite DE; 2) NEMA design A
 Note - 'R' before the frame designates the motor has Roller bearings
 NEMA Premium is a certification mark of the National Electrical Manufacturer's Association.
 QuikMOD Delivery is for stocked motors only.



SIMOTICS Severe Duty Motors

SD100 IEEE (Continued)

SD100 IEEE841 (Cast Iron Frame) Rotor: Die Cast Aluminum Eff: NEMA Premium					Delivery Category:			Stock		
								Quick Mod		
								Custom Build		
Power HP	Speed Rpm	NEMA Frame	Base Part Number ■ ■ ■ = digits 14,15,16	Voltage	Digits 14,15,16			Eff	Weight Lbs	
					Foot Mounted	Foot Mounted C-Face	Round Body C-Face			
					AA3	EA3**	GA3**			
					List Price \$					
25	3600	284TS	1LE2421-2DA11-2 ■ ■ ■	460	3,231	4,101	4,170	91.7%	415	
25	1800	284T	1LE2421-2CB11-2 ■ ■ ■	460	3,086	3,956	4,025	93.6%	445	
25	1800	284TS	1LE2421-2DB11-2 ■ ■ ■	460	3,086	3,956	4,025	93.6%	445	
25	1200	324T	1LE2421-3AC11-2 ■ ■ ■	460	5,227	6,168	6,256	93.0%	640	
25	900	326T	1LE2421-3AD21-2 ■ ■ ■	460	7,986	8,927	9,015	90.2%	582	
30	3600	286TS	1LE2421-2DA21-2 ■ ■ ■	460	3,775	4,645	4,714	91.7%	430	
30	1800	286T	1LE2421-2CB21-2 ■ ■ ■	460	3,588	4,458	4,527	93.6%	465	
30	1800	286TS	1LE2421-2DB21-2 ■ ■ ■	460	3,588	4,458	4,527	93.6%	465	
30	1200	326T	1LE2421-3AC21-2 ■ ■ ■	460	6,022	6,963	7,051	93.0%	675	
30	900	364T	1LE2421-3CD11-2 ■ ■ ■	460	9,453	10,469	10,761	91.7%	740	
40	3600	324TS	1LE2421-3BA11-2 ■ ■ ■	460	4,978	5,919	6,007	93.6%	575	
40	1800	324T	1LE2421-3AB11-2 ■ ■ ■	460	4,767	5,708	5,796	94.1%	666	
40	1800	324TS	1LE2421-3BB11-2 ■ ■ ■	460	4,767	5,708	5,796	94.1%	666	
40	1200	364T	1LE2421-3CC11-2 ■ ■ ■	460	8,160	9,176	9,468	94.1%	863	
40	900	365T	1LE2421-3CD21-2 ■ ■ ■	460	11,428	12,444	12,736	91.7%	840	
50	3600	326TS	1LE2421-3BA21-2 ■ ■ ■	460	6,328	7,269	7,357	93.6%	610	
50	1800	326T	1LE2421-3AB21-2 ■ ■ ■	460	5,803	6,744	6,832	94.5%	700	
50	1800	326TS	1LE2421-3BB21-2 ■ ■ ■	460	5,803	6,744	6,832	94.5%	700	
50	1200	365T	1LE2421-3CC21-2 ■ ■ ■	460	9,287	10,303	10,595	94.1%	900	
50	900	404T	1LE2421-4AD11-2 ■ ■ ■	460	13,302	14,563	14,986	92.4%	1116	
60	3600	364TS	1LE2421-3DA11-2 ■ ■ ■	460	8,398	9,414	9,706	93.6%	717	
60	1800	364T	1LE2421-3CB11-2 ■ ■ ■	460	8,253	9,269	9,561	95.0%	930	
60	1800	364TS	1LE2421-3DB11-2 ■ ■ ■	460	8,253	9,269	9,561	95.0%	930	
60	1200	404T	1LE2421-4AC11-2 ■ ■ ■	460	10,599	11,860	12,283	94.5%	1100	
60	900	405T	1LE2421-4AD21-2 ■ ■ ■	460	14,927	16,188	16,611	92.4%	1182	
75	3600	365TS	1LE2421-3DA21-2 ■ ■ ■	460	10,545	11,561	11,853	94.1%	815	
75	1800	365T	1LE2421-3CB21-2 ■ ■ ■	460	10,279	11,295	11,587	95.4%	1000	
75	1800	365TS	1LE2421-3DB21-2 ■ ■ ■	460	10,279	11,295	11,587	95.4%	1000	
75	1200	405T	1LE2421-4AC21-2 ■ ■ ■	460	12,368	13,629	14,052	94.5%	1150	
75	900	R444T	1LE2421-4CD11-2 ■ ■ ■	460	20,456	--	--	93.6%	1525	
75	900	444TS	1LE2421-4DD11-2 ■ ■ ■	460	19,848	21,341	22,151	93.6%	1525	
75	900	444T	1LE2421-4ED11-2 ■ ■ ■	460	19,848	21,341	22,151	93.6%	1525	

**Add 'C' after frame. Ex. 184TC; 1) CW Rotation facing opposite DE; 2) NEMA design A
 Note - 'R' before the frame designates the motor has Roller bearings
 NEMA Premium is a certification mark of the National Electrical Manufacturer's Association.
 QuikMOD Delivery is for stocked motors only.



SIMOTICS Severe Duty Motors

SD100 IEEE (Continued)

SD100 IEEE841 (Cast Iron Frame) Rotor: Die Cast Aluminum Eff: NEMA Premium					Delivery Category:			Stock	Quick Mod	Custom Build
Power HP	Speed Rpm	NEMA Frame	Base Part Number ■ ■ ■ = digits 14,15,16	Voltage	Digits 14,15,16			Eff	Weight Lbs	
					Foot Mounted	Foot Mounted C-Face	Round Body C-Face			
					AA3	EA3**	GA3**			
					List Price \$					
100	3600	405TS	1LE2421-4BA21-2 ■ ■ ■	460	14,007	15,268	15,691	94.1%	1100	
100	1800	405T	1LE2421-4AB21-2 ■ ■ ■	460	12,699	13,960	14,383	95.4%	1160	
100	1800	405TS	1LE2421-4BB21-2 ■ ■ ■	460	12,699	13,960	14,383	95.4%	1160	
100	1200	R444T	1LE2421-4CC11-2 ■ ■ ■	460	17,662	--	--	95.0%	1545	
100	1200	444TS	1LE2421-4DC11-2 ■ ■ ■	460	17,054	18,547	19,357	95.0%	1545	
100	1200	444T	1LE2421-4EC11-2 ■ ■ ■	460	17,054	18,547	19,357	95.0%	1545	
100	900	R445T	1LE2421-4CD21-2 ■ ■ ■	460	24,930	--	--	94.1%	1697	
100	900	445TS	1LE2421-4DD21-2 ■ ■ ■	460	24,322	25,815	26,625	94.1%	1697	
100	900	445T	1LE2421-4ED21-2 ■ ■ ■	460	24,322	25,815	26,625	94.1%	1697	
125	3600	444TS	1LE2421-4DA11-2 ■ ■ ■	460	17,992	--	--	95.0%	1454	
125	1800	R444T	1LE2421-4CB11-2 ■ ■ ■	460	17,178	--	--	95.4%	1600	
125	1800	444TS	1LE2421-4DB11-2 ■ ■ ■	460	16,570	18,063	18,873	95.4%	1600	
125	1800	444T	1LE2421-4EB11-2 ■ ■ ■	460	16,570	18,063	18,873	95.4%	1600	
125	1200	R445T	1LE2421-4CC21-2 ■ ■ ■	460	21,185	--	--	95.0%	1720	
125	1200	445TS	1LE2421-4DC21-2 ■ ■ ■	460	20,577	22,070	22,880	95.0%	1720	
125	1200	445T	1LE2421-4EC21-2 ■ ■ ■	460	20,577	22,070	22,880	95.0%	1720	
125	900	R447T	1LE2421-4CD31-2 ■ ■ ■	460	25,592	--	--	94.1%	2018	
125	900	447TS	1LE2421-4DD31-2 ■ ■ ■	460	24,984	26,477	27,287	94.1%	2018	
125	900	447T	1LE2421-4ED31-2 ■ ■ ■	460	24,984	26,477	27,287	94.1%	2018	
150	3600	445TS	1LE2421-4DA21-2 ■ ■ ■	460	21,035	--	--	95.0%	1615	
150	1800	R445T	1LE2421-4CB21-2 ■ ■ ■	460	19,350	--	--	95.8%	1710	
150	1800	445TS	1LE2421-4DB21-2 ■ ■ ■	460	18,742	20,235	21,045	95.8%	1710	
150	1800	445T	1LE2421-4EB21-2 ■ ■ ■	460	18,742	20,235	21,045	95.8%	1710	
150	1200	R447T	1LE2421-4CC31-2 ■ ■ ■	460	23,210	--	--	95.8%	1995	
150	1200	447TS	1LE2421-4DC31-2 ■ ■ ■	460	22,602	24,095	24,905	95.8%	1995	
150	1200	447T	1LE2421-4EC31-2 ■ ■ ■	460	22,602	24,095	24,905	95.8%	1995	
150	900	R449T	1LE2421-4CD51-2 ■ ■ ■	460	32,553	--	--	94.1%	2480	
150	900	449TS	1LE2421-4DD51-2 ■ ■ ■	460	31,945	33,438	34,248	94.1%	2480	
150	900	449T	1LE2421-4ED51-2 ■ ■ ■	460	31,945	33,438	34,248	94.1%	2480	
200	3600	447TS	1LE2421-4DA31-2 ■ ■ ■	460	26,380	--	--	95.4%	1890	
200	1800	R447T	1LE2421-4CB31-2 ■ ■ ■	460	23,404	--	--	96.2%	2035	
200	1800	447TS	1LE2421-4DB31-2 ■ ■ ■	460	22,796	24,289	25,099	96.2%	2035	
200	1800	447T	1LE2421-4EB31-2 ■ ■ ■	460	22,796	24,289	25,099	96.2%	2035	
200	1200	R449T	1LE2421-4CC51-2 ■ ■ ■	460	28,021	--	--	95.8%	2425	
200	1200	449TS	1LE2421-4DC51-2 ■ ■ ■	460	27,413	28,906	29,716	95.8%	2425	
200	1200	449T	1LE2421-4EC51-2 ■ ■ ■	460	27,413	28,906	29,716	95.8%	2425	
200	900	RS449LS	1LE2421-4FD11-2 ■ ■ ■	460	46,134	--	--	94.5%	3200	

**Add 'C' after frame. Ex. 184TC; 1) CW Rotation facing opposite DE; 2) NEMA design A
 Note - 'R' before the frame designates the motor has Roller bearings
 NEMA Premium is a certification mark of the National Electrical Manufacturer's Association.
 QuikMOD Delivery is for stocked motors only.



SIMOTICS Severe Duty Motors

SD100 IEEE (Continued)

SD100 IEEE841 (Cast Iron Frame) Rotor: Die Cast Aluminum Eff: NEMA Premium					Delivery Category:			Stock	
					Quick Mod				
					Custom Build				
Power HP	Speed Rpm	NEMA Frame	Base Part Number ■ ■ ■ = digits 14,15,16	Voltage	Digits 14,15,16			Eff	Weight Lbs
					Foot Mounted	Foot Mounted C-Face	Round Body C-Face		
					AA3	EA3**	GA3**		
					List Price \$				
250	3600	449TS	1LE2421-4DA51-2 ■ ■ ■	460	33,581	--	--	95.8%	2272
250	1800	R449T ²⁾	1LE2421-4CB51-2 ■ ■ ■	460	29,498	--	--	96.2%	2425
250	1800	449TS ²⁾	1LE2421-4DB51-2 ■ ■ ■	460	28,890	30,383	31,193	96.2%	2425
250	1800	449T ²⁾	1LE2421-4EB51-2 ■ ■ ■	460	28,890	30,383	31,193	96.2%	2425
250	1200	R449T ²⁾	1LE2421-4CC61-2 ■ ■ ■	460	30,733	--	--	95.8%	2390
250	1200	449TS ²⁾	1LE2421-4DC61-2 ■ ■ ■	460	30,125	31,618	32,428	95.8%	2390
250	1200	449T ²⁾	1LE2421-4EC61-2 ■ ■ ■	460	30,125	31,618	32,428	95.8%	2390
250	900	RS449LS	1LE2421-4FD21-2 ■ ■ ■	460	50,486	--	--	94.5%	3220
300	3600	449TS	1LE2421-4DA61-2 ■ ■ ■	460	42,635	--	--	95.8%	2200
300	1800	RS449LS ¹⁾	1LE2421-4FB11-2 ■ ■ ■	460	39,785	--	--	96.2%	3130
300	1800	S449SS ¹⁾	1LE2421-4GB11-2 ■ ■ ■	460	39,177	CF	--	96.2%	3130
300	1200	RS449LS ²⁾	1LE2421-4FC11-2 ■ ■ ■	460	52,950	--	--	95.8%	3240
300	1200	S449SS ²⁾	1LE2421-4GC11-2 ■ ■ ■	460	52,342	CF	--	95.8%	3240
350	3600	S449SS ¹⁾	1LE2421-4GA11-2 ■ ■ ■	460	51,006	--	--	95.8%	2890
350	1800	RS449LS ¹⁾	1LE2421-4FB21-2 ■ ■ ■	460	47,844	--	--	96.2%	3190
350	1800	S449SS ¹⁾	1LE2421-4GB21--2 ■ ■ ■	460	47,236	CF	--	96.2%	3190
400	3600	S449SS ¹⁾	1LE2421-4GA31-2 ■ ■ ■	460	57,207	--	--	95.8%	3065
400	1800	RS449LS ¹⁾	1LE2421-4FB31-2 ■ ■ ■	460	53,594	--	--	96.2%	3240
400	1800	S449SS ¹⁾	1LE2421-4GB31-2 ■ ■ ■	460	52,986	CF	--	96.2%	3240

**Add 'C' after frame. Ex. 184TC; 1) CW Rotation facing opposite DE; 2) NEMA design A
 Note - 'R' before the frame designates the motor has Roller bearings
 NEMA Premium is a certification mark of the National Electrical Manufacturer's Association.
 QuikMOD Delivery is for stocked motors only.



SIMOTICS Severe Duty Motors

SD100 IEEE Cu

SD100 IEEE841 (Cast Iron Frame) Rotor: Die Cast Copper Eff: NEMA Premium					Delivery Category:			Stock		
								Quick Mod	Custom Build	
Power HP	Speed Rpm	NEMA Frame	Base Part Number ■ ■ ■ = digits 14,15,16	Voltage	Digits 14,15,16			Eff	Weight Lbs	
					Foot Mounted	Foot Mounted C-Face	Round Body C-Face			
					AA3	EA3**	GA3**			
					List Price \$					
1	1800	143T	1LE2411-1AB21-2 ■ ■ ■	460	886	992	976	86.5%	81	
1	1200	145T	1LE2411-1AC31-2 ■ ■ ■	460	1,044	1,150	870	84.0%	81	
1 1/2	3600	143T	1LE2411-1AA21-2 ■ ■ ■	460	917	1023	761	87.5%	80	
1 1/2	1800	145T	1LE2411-1AB31-2 ■ ■ ■	460	955	1061	785	87.5%	81	
2	3600	145T	1LE2411-1AA31-2 ■ ■ ■	460	1,051	1157	892	88.5%	80	
2	1800	145T	1LE2411-1AB41-2 ■ ■ ■	460	1,023	1129	1,113	87.5%	81	
3	3600	182T	1LE2411-1CA11-2 ■ ■ ■	460	1,102	1,256	1,234	89.5%	121	
3	1800	182T	1LE2411-1CB11-2 ■ ■ ■	460	1,056	1210	1,188	90.2%	125	
3	1200	213T	1LE2411-2AC11-2 ■ ■ ■	460	1,571	1735	1,703	90.2%	170	
5	3600	184T	1LE2411-1CA31-2 ■ ■ ■	460	1,348	1502	1,480	90.2%	123	
5	1800	184T	1LE2411-1CB31-2 ■ ■ ■	460	1,209	1363	1,341	90.2%	129	
5	1200	215T	1LE2411-2AC21-2 ■ ■ ■	460	2,077	2,241	2,209	90.2%	184	
7 1/2	3600	213T	1LE2411-2AA11-2 ■ ■ ■	460	1,653	1,817	1,785	91.7%	191	
7 1/2	1800	213T	1LE2411-2AB11-2 ■ ■ ■	460	1,605	1,769	1,737	92.4%	198	
7 1/2	1200	254T	1LE2411-2BC11-2 ■ ■ ■	460	2,656	2,885	2,836	92.4%	336	
10	3600	215T	1LE2411-2AA21-2 ■ ■ ■	460	1,900	2,064	2,032	91.7%	196	
10	1800	215T	1LE2411-2AB21-2 ■ ■ ■	460	1,922	2,086	2,054	92.4%	206	
10	1200	256T	1LE2411-2BC21-2 ■ ■ ■	460	3,305	3,534	3,485	92.4%	337	
15	3600	254T	1LE2411-2BA11-2 ■ ■ ■	460	2,577	2,806	2,757	92.4%	309	
15	1800	254T	1LE2411-2BB11-2 ■ ■ ■	460	2,531	2,760	2,711	93.0%	297	
20	3600	256T	1LE2411-2BA21-2 ■ ■ ■	460	3,164	3,393	3,344	92.4%	333	
20	1800	256T	1LE2411-2BB21-2 ■ ■ ■	460	3,263	3,492	3,443	93.6%	341	

**Add 'C' after frame. Ex. 184TC;

NEMA Premium is a certification mark of the National Electrical Manufacturer's Association.

QuikMOD Delivery is for stocked motors only.



SIMOTICS Severe Duty Motors

SD100 IEEE 575

SD100 IEEE841 (Cast Iron Frame) Rotor: Die Cast Aluminum Eff: NEMA Premium					Delivery Category:			Stock		
								Quick Mod		
								Custom Build		
Power HP	Speed Rpm	NEMA Frame	Base Part Number ■ ■ ■ = digits 14,15,16	Voltage	Digits 14,15,16			Eff	Weight Lbs	
					Foot Mounted	Foot Mounted C-Face	Round Body C-Face			
					AA3	EA3**	GA3**			
					List Price \$					
1	3600	143T	1LE2421-1AA11-3 ■■■	575	787	893	877	82.5%	75	
1	1800	143T	1LE2421-1AB21-3 ■■■	575	762	868	852	85.5%	76	
1	1200	145T	1LE2421-1AC31-3 ■■■	575	898	1004	988	82.5%	77	
1	900	182T	1LE2421-1CD11-3 ■■■	575	1,457	1611	1,589	81.5%	106	
1 1/2	3600	143T	1LE2421-1AA21-3 ■■■	575	788	894	878	84.0%	70	
1 1/2	1800	145T	1LE2421-1AB31-3 ■■■	575	822	928	912	86.5%	80	
1 1/2	1200	182T	1LE2421-1CC11-3 ■■■	575	1,006	1,160	1,138	87.5%	113	
1 1/2	900	184T	1LE2421-1CD31-3 ■■■	575	1,719	1873	1,851	82.5%	119	
2	3600	145T	1LE2421-1AA31-3 ■■■	575	904	1010	994	85.5%	72	
2	1800	145T	1LE2421-1AB41-3 ■■■	575	878	984	968	86.5%	80	
2	1200	184T	1LE2421-1CC31-3 ■■■	575	1,071	1225	1,203	88.5%	122	
2	900	213T	1LE2421-2AD11-3 ■■■	575	2,023	2,187	2,155	84.0%	145	
3	3600	182T	1LE2421-1CA11-3 ■■■	575	947	1,101	1,079	86.5%	107	
3	1800	182T	1LE2421-1CB11-3 ■■■	575	907	1,061	1,039	89.5%	118	
3	1200	213T	1LE2421-2AC11-3 ■■■	575	1,350	1,514	1,482	89.5%	164	
3	900	215T	1LE2421-2AD21-3 ■■■	575	2,565	2,729	2,697	85.5%	160	
5	3600	184T	1LE2421-1CA31-3 ■■■	575	1,159	1,313	1,291	88.5%	118	
5	1800	184T	1LE2421-1CB31-3 ■■■	575	1,039	1,193	1,171	89.5%	124	
5	1200	215T	1LE2421-2AC21-3 ■■■	575	1,787	1,951	1,919	89.5%	176	
5	900	254T	1LE2421-2BD11-3 ■■■	575	3,428	3,657	3,608	86.5%	247	
7 1/2	3600	213T	1LE2421-2AA11-3 ■■■	575	1,421	1,585	1,553	89.5%	160	
7 1/2	1800	213T	1LE2421-2AB11-3 ■■■	575	1,380	1,544	1,512	91.7%	191	
7 1/2	1200	254T	1LE2421-2BC11-3 ■■■	575	2,284	2,513	2,464	91.0%	292	
7 1/2	900	256T	1LE2421-2BD21-3 ■■■	575	4,297	4,526	4,477	87.5%	279	
10	3600	215T	1LE2421-2AA21-3 ■■■	575	1,634	1,798	1,766	90.2%	174	
10	1800	215T	1LE2421-2AB21-3 ■■■	575	1,652	1,816	1,784	91.7%	197	
10	1200	256T	1LE2421-2BC21-3 ■■■	575	2,840	3,069	3,020	91.0%	288	
10	900	284T	1LE2421-2CD11-3 ■■■	575	4,398	5,268	5,337	90.2%	362	
15	3600	254T	1LE2421-2BA11-3 ■■■	575	2,216	2,445	2,396	91.0%	287	
15	1800	254T	1LE2421-2BB11-3 ■■■	575	2,177	2,406	2,357	92.4%	289	
15	1200	284T	1LE2421-2CC11-3 ■■■	575	3,541	4,411	4,480	91.7%	400	
15	900	286T	1LE2421-2CD21-3 ■■■	575	5,623	6,493	6,562	90.2%	420	
20	3600	256T	1LE2421-2BA21-3 ■■■	575	2,720	2,949	2,900	91.0%	323	
20	1800	256T	1LE2421-2BB21-3 ■■■	575	2,806	3,035	2,986	93.0%	322	
20	1200	286T	1LE2421-2CC21-3 ■■■	575	4,316	5,186	5,255	91.7%	465	
20	900	324T	1LE2421-3AD11-3 ■■■	575	6,875	7,816	7,904	91.0%	570	

**Add 'C' after frame. Ex. 184TC; 1) CW Rotation facing opposite DE; 2) NEMA design A
 Note - 'R' before the frame designates the motor has Roller bearings
 NEMA Premium is a certification mark of the National Electrical Manufacturer's Association.
 QuikMOD Delivery is for stocked motors only.



SIMOTICS Severe Duty Motors

SD100 IEEE 575 (Continued)

SD100 IEEE841 (Cast Iron Frame) Rotor: Die Cast Aluminum Eff: NEMA Premium					Delivery Category:			Stock	Quick Mod	Custom Build
Power HP	Speed Rpm	NEMA Frame	Base Part Number ■ ■ ■ = digits 14,15,16	Voltage	Digits 14,15,16			Eff	Weight Lbs	
					Foot Mounted	Foot Mounted C-Face	Round Body C-Face			
					AA3	EA3**	GA3**			
					List Price \$					
25	3600	284TS	1LE2421-2DA11-3 ■ ■ ■	575	3,231	4,101	4,170	91.7%	415	
25	1800	284T	1LE2421-2CB11-3 ■ ■ ■	575	3,086	3,956	4,025	93.6%	445	
25	1800	284TS	1LE2421-2DB11-3 ■ ■ ■	575	3,086	3,956	4,025	93.6%	445	
25	1200	324T	1LE2421-3AC11-3 ■ ■ ■	575	5,227	6,168	6,256	93.0%	640	
25	900	326T	1LE2421-3AD21-3 ■ ■ ■	575	7,986	8,927	9,015	90.2%	582	
30	3600	286TS	1LE2421-2DA21-3 ■ ■ ■	575	3,775	4,645	4,714	91.7%	430	
30	1800	286T	1LE2421-2CB21-3 ■ ■ ■	575	3,588	4,458	4,527	93.6%	465	
30	1800	286TS	1LE2421-2DB21-3 ■ ■ ■	575	3,588	4,458	4,527	93.6%	465	
30	1200	326T	1LE2421-3AC21-3 ■ ■ ■	575	6,022	6,963	7,051	93.0%	675	
30	900	364T	1LE2421-3CD11-3 ■ ■ ■	575	9,453	10,469	10,761	91.7%	740	
40	3600	324TS	1LE2421-3BA11-3 ■ ■ ■	575	4,978	5,919	6,007	93.6%	575	
40	1800	324T	1LE2421-3AB11-3 ■ ■ ■	575	4,767	5,708	5,796	94.1%	666	
40	1800	324TS	1LE2421-3BB11-3 ■ ■ ■	575	4,767	5,708	5,796	94.1%	666	
40	1200	364T	1LE2421-3CC11-3 ■ ■ ■	575	8,160	9,176	9,468	94.1%	863	
40	900	365T	1LE2421-3CD21-3 ■ ■ ■	575	11,428	12,444	12,736	91.7%	840	
50	3600	326TS	1LE2421-3BA21-3 ■ ■ ■	575	6,328	7,269	7,357	93.6%	610	
50	1800	326T	1LE2421-3AB21-3 ■ ■ ■	575	5,803	6,744	6,832	94.5%	700	
50	1800	326TS	1LE2421-3BB21-3 ■ ■ ■	575	5,803	6,744	6,832	94.5%	700	
50	1200	365T	1LE2421-3CC21-3 ■ ■ ■	575	9,287	10,303	10,595	94.1%	900	
50	900	404T	1LE2421-4AD11-3 ■ ■ ■	575	13,302	14,563	14,986	92.4%	1116	
60	3600	364TS	1LE2421-3DA11-3 ■ ■ ■	575	8,398	9,414	9,706	93.6%	717	
60	1800	364T	1LE2421-3CB11-3 ■ ■ ■	575	8,253	9,269	9,561	95.0%	930	
60	1800	364TS	1LE2421-3DB11-3 ■ ■ ■	575	8,253	9,269	9,561	95.0%	930	
60	1200	404T	1LE2421-4AC11-3 ■ ■ ■	575	10,599	11,860	12,283	94.5%	1100	
60	900	405T	1LE2421-4AD21-3 ■ ■ ■	575	14,927	16,188	16,611	92.4%	1182	
75	3600	365TS	1LE2421-3DA21-3 ■ ■ ■	575	10,545	11,561	11,853	94.1%	815	
75	1800	365T	1LE2421-3CB21-3 ■ ■ ■	575	10,279	11,295	11,587	95.4%	1000	
75	1800	365TS	1LE2421-3DB21-3 ■ ■ ■	575	10,279	11,295	11,587	95.4%	1000	
75	1200	405T	1LE2421-4AC21-3 ■ ■ ■	575	12,368	13,629	14,052	94.5%	1150	
75	900	R444T	1LE2421-4CD11-3 ■ ■ ■	575	20,456	--	--	93.6%	1525	
75	900	444TS	1LE2421-4DD11-3 ■ ■ ■	575	19,848	21,341	22,151	93.6%	1525	
75	900	444T	1LE2421-4ED11-3 ■ ■ ■	575	24,322	25,815	26,625	93.6%	1525	

**Add 'C' after frame. Ex. 184TC; 1) CW Rotation facing opposite DE; 2) NEMA design A
 Note - 'R' before the frame designates the motor has Roller bearings
 NEMA Premium is a certification mark of the National Electrical Manufacturer's Association.
 QuikMOD Delivery is for stocked motors only.



SIMOTICS Severe Duty Motors

SD100 IEEE 575 (Continued)

SD100 IEEE841 (Cast Iron Frame) Rotor: Die Cast Aluminum Eff: NEMA Premium					Delivery Category:			Stock		
								Quick Mod		
								Custom Build		
Power HP	Speed Rpm	NEMA Frame	Base Part Number ■ ■ ■ = digits 14,15,16	Voltage	Digits 14,15,16			Eff	Weight Lbs	
					Foot Mounted	Foot Mounted C-Face	Round Body C-Face			
					AA3	EA3**	GA3**			
					List Price \$					
100	3600	405TS	1LE2421-4BA21-3 ■■■	575	14,007	15,268	15,691	94.1%	1100	
100	1800	405T	1LE2421-4AB21-3 ■■■	575	12,699	13,960	14,383	95.4%	1160	
100	1800	405TS	1LE2421-4BB21-3 ■■■	575	12,699	13,960	14,383	95.4%	1160	
100	1200	R444T	1LE2421-4CC11-3 ■■■	575	17,662	--	--	95.0%	1545	
100	1200	444TS	1LE2421-4DC11-3 ■■■	575	17,054	18,547	19,357	95.0%	1545	
100	1200	444T	1LE2421-4EC11-3 ■■■	575	17,054	18,547	19,357	95.0%	1545	
100	900	R445T	1LE2421-4CD21-3 ■■■	575	24,930	--	--	94.1%	1697	
100	900	445TS	1LE2421-4DD21-3 ■■■	575	24,322	25,815	26,625	94.1%	1697	
100	900	445T	1LE2421-4ED21-3 ■■■	575	24,322	25,815	26,625	94.1%	1697	
125	3600	444TS	1LE2421-4DA11-3 ■■■	575	17,992	--	--	95.0%	1454	
125	1800	R444T	1LE2421-4CB11-3 ■■■	575	17,178	--	--	95.4%	1600	
125	1800	444TS	1LE2421-4DB11-3 ■■■	575	16,570	18,063	18,873	95.4%	1600	
125	1800	444T	1LE2421-4EB11-3 ■■■	575	16,570	18,063	18,873	95.4%	1600	
125	1200	R445T	1LE2421-4CC21-3 ■■■	575	21,185	--	--	95.0%	1720	
125	1200	445TS	1LE2421-4DC21-3 ■■■	575	20,577	22,070	22,880	95.0%	1720	
125	1200	445T	1LE2421-4EC21-3 ■■■	575	20,577	22,070	22,880	95.0%	1720	
125	900	R447T	1LE2421-4CD31-3 ■■■	575	25,592	--	--	94.1%	2018	
125	900	447TS	1LE2421-4DD31-3 ■■■	575	24,984	26,477	27,287	94.1%	2018	
125	900	447T	1LE2421-4ED31-3 ■■■	575	24,984	26,477	27,287	94.1%	2018	
150	3600	445TS	1LE2421-4DA21-3 ■■■	575	21,035	--	--	95.0%	1615	
150	1800	R445T	1LE2421-4CB21-3 ■■■	575	19,350	--	--	95.8%	1710	
150	1800	445TS	1LE2421-4DB21-3 ■■■	575	18,742	20,235	21,045	95.8%	1710	
150	1800	445T	1LE2421-4EB21-3 ■■■	575	18,742	20,235	21,045	95.8%	1710	
150	1200	R447T	1LE2421-4CC31-3 ■■■	575	23,210	--	--	95.8%	1995	
150	1200	447TS	1LE2421-4DC31-3 ■■■	575	22,602	24,095	24,905	95.8%	1995	
150	1200	447T	1LE2421-4EC31-3 ■■■	575	22,602	24,095	24,905	95.8%	1995	
150	900	R449T	1LE2421-4CD51-3 ■■■	575	32,553	--	--	94.1%	2480	
150	900	449TS	1LE2421-4DD51-3 ■■■	575	31,945	33,438	34,248	94.1%	2480	
150	900	449T	1LE2421-4ED51-3 ■■■	575	31,945	33,438	34,248	94.1%	2480	
200	3600	447TS	1LE2421-4DA31-3 ■■■	575	26,380	--	--	95.4%	1890	
200	1800	R447T	1LE2421-4CB31-3 ■■■	575	23,404	--	--	96.2%	2035	
200	1800	447TS	1LE2421-4DB31-3 ■■■	575	22,796	24,289	25,099	96.2%	2035	
200	1800	447T	1LE2421-4EB31-3 ■■■	575	22,796	24,289	25,099	96.2%	2035	
200	1200	R449T	1LE2421-4CC51-3 ■■■	575	28,021	--	--	95.8%	2425	
200	1200	449TS	1LE2421-4DC51-3 ■■■	575	27,413	28,906	29,716	95.8%	2425	
200	1200	449T	1LE2421-4EC51-3 ■■■	575	27,413	28,906	29,716	95.8%	2425	
200	900	RS449LS	1LE2421-4FD11-3 ■■■	575	46,134	--	--	94.5%	3200	

**Add 'C' after frame. Ex. 184TC; 1) CW Rotation facing opposite DE; 2) NEMA design A

Note - 'R' before the frame designates the motor has Roller bearings

NEMA Premium is a certification mark of the National Electrical Manufacturer's Association.

QuikMOD Delivery is for stocked motors only.



SIMOTICS Severe Duty Motors

SD100 IEEE 575 (Continued)

SD100 IEEE841 (Cast Iron Frame) Rotor: Die Cast Aluminum Eff: NEMA Premium					Delivery Category:			Stock	Quick Mod	Custom Build
Power HP	Speed Rpm	NEMA Frame	Base Part Number ■ ■ ■ = digits 14,15,16	Voltage	Digits 14,15,16			Eff	Weight Lbs	
					Foot Mounted	Foot Mounted C-Face	Round Body C-Face			
					AA3	EA3**	GA3**			
					List Price \$					
250	3600	449TS	1LE2421-4DA51-3 ■ ■ ■	575	33,581	--	--	95.8%	2272	
250	1800	R449T ²⁾	1LE2421-4CB51-3 ■ ■ ■	575	29,498	--	--	96.2%	2425	
250	1800	449TS	1LE2421-4DB51-3 ■ ■ ■	575	28,890	30,383	31,193	96.2%	2425	
250	1800	449T	1LE2421-4EB51-3 ■ ■ ■	575	28,890	30,383	31,193	96.2%	2425	
250	1200	R449T ²⁾	1LE2421-4CC61-3 ■ ■ ■	575	30,733	--	--	95.8%	2390	
250	1200	449TS	1LE2421-4DC61-3 ■ ■ ■	575	30,125	31,618	32,428	95.8%	2390	
250	1200	449T	1LE2421-4EC61-3 ■ ■ ■	575	30,125	31,618	32,428	95.8%	2390	
250	900	RS449LS	1LE2421-4FD21-3 ■ ■ ■	575	50,486	--	--	94.5%	3220	
300	3600	449TS	1LE2421-4DA61-3 ■ ■ ■	575	42,635	--	--	95.8%	2200	
300	1800	RS449LS ^{1),2)}	1LE2421-4FB11-3 ■ ■ ■	575	39,785	--	--	96.2%	3130	
300	1800	S449SS	1LE2421-4GB11-3 ■ ■ ■	575	39,177	CF	--	96.2%	3130	
300	1200	RS449LS ²⁾	1LE2421-4FC11-3 ■ ■ ■	575	52,950	--	--	95.8%	3240	
300	1200	S449SS	1LE2421-4GC11-3 ■ ■ ■	575	52,342	CF	--	95.8%	3240	
350	3600	S449SS	1LE2421-4GA11-3 ■ ■ ■	575	51,006	--	--	95.8%	2890	
350	1800	RS449LS ¹⁾	1LE2421-4FB21-3 ■ ■ ■	575	47,844	--	--	96.2%	3190	
350	1800	S449SS	1LE2421-4GB21-3 ■ ■ ■	575	47,236	CF	--	96.2%	3190	
400	3600	S449SS	1LE2421-4GA31-3 ■ ■ ■	575	57,207	--	--	95.8%	3065	
400	1800	RS449LS ¹⁾	1LE2421-4FB31-3 ■ ■ ■	575	53,594	--	--	96.2%	3240	
400	1800	S449SS	1LE2421-4GB31-3 ■ ■ ■	575	52,986	CF	--	96.2%	3240	

**Add 'C' after frame. Ex. 184TC; 1) CW Rotation facing opposite DE; 2) NEMA design A
 Note - 'R' before the frame designates the motor has Roller bearings
 NEMA Premium is a certification mark of the National Electrical Manufacturer's Association.
 QuikMOD Delivery is for stocked motors only.



SIMOTICS Severe Duty Motors

SD661

SD661 (Cast Iron Frame) Rotor: Die Cast Aluminum Eff: NEMA Premium						Delivery Category:	Stock	Quick Mod	Custom Build
Power HP	Speed Rpm	NEMA Frame	Base Part Number	Voltage	Foot Mounted	FL Amps	Eff	Weight Lbs	
					List price				
5	1800	184T	1LE2422-1CB31-2AA3	460	1,039	6.5	89.5%	124	
7 1/2	1800	R213T	1LE2422-2AB11-2AA3	460	1,568	9.7	91.7%	191	
7 1/2	1200	R254T	1LE2422-2BC11-2AA3	460	2,542	10.0	91.0%	272	
10	1800	R215T	1LE2422-2AB21-2AA3	460	1,842	12.5	91.7%	197	
10	1200	R256T	1LE2422-2BC21-2AA3	460	3,147	13.5	91.0%	288	
15	1800	R254T	1LE2422-2BB11-2AA3	460	2,435	19.0	92.4%	289	
15	1200	R284T	1LE2422-2CC11-2AA3	460	3,868	21.0	91.7%	400	
20	1800	R256T	1LE2422-2BB21-2AA3	460	3,113	25.0	93.0%	322	
20	1200	R286T	1LE2422-2CC21-2AA3	460	4,638	27.0	91.7%	465	
25	1800	R284T	1LE2422-2CB11-2AA3	460	3,413	30.0	93.6%	445	
25	1200	R324T	1LE2422-3AC11-2AA3	460	5,636	33.0	93.0%	640	
30	1800	R286T	1LE2422-2CB21-2AA3	460	3,910	35.0	93.6%	465	
30	1200	R326T	1LE2422-3AC21-2AA3	460	6,448	39.0	93.0%	675	
40	1800	R324T	1LE2422-3AB11-2AA3	460	5,176	46.0	94.1%	666	
40	1800	R364T	1LE2422-3CC11-2AA3	460	8,659	49.0	94.1%	863	
50	1800	R326T	1LE2422-3AB21-2AA3	460	6,229	58.0	94.5%	700	
50	1200	R365T	1LE2422-3CC21-2AA3	460	9,822	62.0	94.1%	900	
60	1800	R364T	1LE2422-3CB11-2AA3	460	8,752	68.0	95.0%	930	
75	1800	R365T	1LE2422-3CB21-2AA3	460	10,814	85.0	95.4%	1000	
5	1800	184T	1LE2422-1CB31-3AA3	575	1,039	6.5	89.5%	124	
7 1/2	1800	R213T	1LE2422-2AB11-3AA3	575	1,568	9.7	91.7%	191	
10	1800	R215T	1LE2422-2AB21-3AA3	575	1,842	12.5	91.7%	197	
15	1800	R254T	1LE2422-2BB11-3AA3	575	2,435	19.0	92.4%	289	
20	1800	R256T	1LE2422-2BB21-3AA3	575	3,113	25.0	93.0%	322	
25	1800	R284T	1LE2422-2CB11-3AA3	575	3,413	30.0	93.6%	445	
30	1800	R286T	1LE2422-2CB21-3AA3	575	3,910	35.0	93.6%	465	
40	1800	R324T	1LE2422-3AB11-3AA3	575	5,176	46.0	94.1%	666	
50	1800	R326T	1LE242-23AB21-3AA3	575	6,229	58.0	94.5%	700	
60	1800	R364T	1LE2422-3CB11-3AA3	575	8,752	68.0	95.0%	930	
75	1800	R365T	1LE2422-3CB21-3AA3	575	10,814	85.0	95.4%	1000	

Note - 'R' before the frame designates the motor has Roller bearings
 NEMA Premium is a certification mark of the National Electrical Manufacturer's Association.
 QuikMOD Delivery is for stocked motors only.



SIMOTICS Severe Duty Motors

SD200

SD200 (Cast Iron Frame) Rotor: Die Cast Aluminum Eff: NEMA Premium					Delivery Category:			Stock	Quick Mod	Custom Build
Power HP	Speed Rpm	NEMA Frame	Base Part Number ■ ■ ■ = digits 14,15,16	Voltage	Digits 14,15,16			Eff	Weight Lbs	
					Foot Mounted, No Protection	Foot Mounted w/ Stator RTDs*	FLC Amps			
					AA1	AK1				
			List Price \$							
350	1200	5010	1LE6321-5AC21-2 ■■■	460	56,690	63,250	400	95.8%	4,387	
350	1200	5010S	1LE6321-5EC21-2 ■■■	460	54,760	61,320	400	95.8%	4,387	
350	1200	R5010	1LE6321-5RC21-2 ■■■	460	57,940	64,500	400	95.8%	4,387	
400	3600	509S	1LE6321-5EA11-2 ■■■	460	55,650	62,210	435	96.2%	4,219	
400	1800	509	1LE6321-5AB11-2 ■■■	460	54,380	60,940	455	96.5%	4,105	
400	1800	509S	1LE6321-5EB11-2 ■■■	460	54,380	60,940	455	96.5%	4,105	
400	1800	R509	1LE6321-5RB11-2 ■■■	460	55,630	62,190	455	96.5%	4,105	
400	1200	5011	1LE6321-5AC81-2 ■■■	460	59,920	66,480	457	95.8%	4,529	
400	1200	5011S	1LE6321-5EC81-2 ■■■	460	59,920	66,480	457	95.8%	4,529	
400	1200	R5011	1LE6321-5RC81-2 ■■■	460	61,170	67,730	457	95.8%	4,529	
450	3600	5010S	1LE6321-5EA21-2 ■■■	460	56,780	63,340	490	96.2%	4,357	
450	1800	509	1LE6321-5AB21-2 ■■■	460	56,120	62,680	515	96.5%	4,302	
450	1800	509S	1LE6321-5EB21-2 ■■■	460	56,120	62,680	515	96.5%	4,302	
450	1800	R509	1LE6321-5RB21-2 ■■■	460	57,370	63,930	515	96.5%	4,302	
450	1200	L5011 ¹⁾	1LE6321-5BC31-2 ■■■	460	68,490	75,050	507	95.8%	5,083	
450	1200	L5011S ¹⁾	1LE6321-5FC31-2 ■■■	460	63,670	70,230	507	95.8%	5,083	
450	1200	RL5011 ¹⁾	1LE6321-5SC31-2 ■■■	460	69,740	76,300	507	95.8%	5,083	
500	3600	5011S	1LE6321-5EA81-2 ■■■	460	57,530	64,090	535	96.2%	4,504	
500	1800	5011	1LE6321-5AB81-2 ■■■	460	56,960	63,520	565	96.5%	4,509	
500	1800	5011S	1LE6321-5EB81-2 ■■■	460	56,960	63,520	565	96.5%	4,509	
500	1800	R5011	1LE6321-5RB81-2 ■■■	460	58,210	64,770	565	96.5%	4,509	
500	1200	5012	1LE6321-5BC51-2 ■■■	460	72,600	79,160	563	95.8%	5,289	
500	1200	5012S	1LE6321-5FC51-2 ■■■	460	70,670	77,230	563	95.8%	5,289	
500	1200	R5012	1LE6321-5SC51-2 ■■■	460	73,850	80,410	563	95.8%	5,289	
600	3600	5011S	1LE6321-5EA01-2 ■■■	460	64,200	70,760	650	96.5%	4,936	
600	1800	5011	1LE6321-5AB01-2 ■■■	460	64,420	70,980	680	96.5%	4,993	
600	1800	5011S	1LE6321-5EB01-2 ■■■	460	64,420	70,980	680	96.5%	4,993	
600	1800	R5011	1LE6321-5RB01-2 ■■■	460	65,680	72,240	680	96.5%	4,993	
600	1200	5013	1LE6321-5BC71-2 ■■■	460	79,170	85,730	675	95.8%	5,391	
600	1200	5013S	1LE6321-5FC71-2 ■■■	460	79,170	85,730	675	95.8%	5,391	
600	1200	R5013	1LE6321-5SC71-2 ■■■	460	80,420	86,980	675	95.8%	5,390	
700	3600	5013S	1LE6321-5FA71-2 ■■■	460	73,880	80,440	760	96.7%	5,538	
700	1800	5013	1LE6321-5BB71-2 ■■■	460	75,990	82,550	790	96.7%	5,592	
700	1800	5013S	1LE6321-5FB71-2 ■■■	460	75,990	82,550	790	96.7%	5,592	
700	1800	R5013	1LE6321-5SB71-2 ■■■	460	77,240	83,800	790	96.7%	5,592	
800	3600	5013S	1LE6321-5FA81-2 ■■■	460	77,580	84,140	850	96.7%	5,798	

*Stator RTD's 100 ohm platinum w aux box-terminal strip 2/phase

1) Longer frame

Note - 'R' before the frame designates the motor has Roller bearings

NEMA Premium is a certification mark of the National Electrical Manufacturer's Association.

QuikMOD Delivery is for stocked motors only.



SIMOTICS Explosion Proof Motors



Introduction

Special Features

Motor Selection and Pricing

Special Features Details

Typical Performance Details

General Dimensions

MV449 Frame

Indexes

Introduction

Siemens Explosion Proof motors are **not only** designed and built to operate under harsh environments in the industry, including but not limited to petrochemical and the **food industry**. Fans, compressors, pumps and conveyors are some of the many applications. These motors are design to meet or exceed the NEMA Premium® efficiency (MG1 Table 12-12) as well as the high requirements for safety and protection established by the NFPA 70 code NEC®. These motors are prepared for different hazardous atmospheres for gas and dust protection, its IP65 ingress protection provides reliability and safety assurance in all cases. The construction of these motors is backed up by its 3 to 5 year warranty.

Performance Specification			
		XP100	XP100 ID1
HP Range	3600 RPM	1-300 HP	
	1800 RPM		
	1200 RPM	1-250 HP	1-200 HP
	900 RPM	1-200 HP	-
Frame Size	140T – 440T	140T-449T, 180JP-210JP	
Standard Voltage (3~ 60 Hz)	230V/460V (Suitable for 208V)	FS 140-250	
	230V/460V	1-100 HP	
	460V	1-300 HP	
	575V		
Efficiency	NEMA Premium® (MG1-Table 12-12)	1-300 HP	
Service Factor	1.15 @ 55°C (Temp Code T3C)	FS 140-360	FS 140-440
	1.15 @ 55°C (Temp Code T3)	FS 360-447	--
	1.15 @ 40°C (Temp Code T3C)	FS 360-447	--
	1.0 @ 40°C (Temp Code T3)	FS 449	--
Insulation	Non-Hygroscopic	Class F	
Temperature Rise	Class B	@ 1.0SF	
	Class F	@ 1.15SF	
Conduit Box (Oversized)	Oversized	Cast Iron	
Fan Cover		Cast Iron	
Cooling Fan	Bi-Directional	Polypropylene	
Rotor	Die Cast Aluminum	FS 140-300	
Ingress Protection	NEMA	IP65	
Hazardous Location	Gas	CL I, Div 1 Gr. C&D	CL I, Div 1 Gr. D
	Dust	CL II, Div 1, Gr F&G ¹⁾	--
Inverter Duty	Variable Torque 20:1	FS 140-440	FS 140-440
	Constant Torque CT 4:1	FS 140-447	FS 140-500
	Constant Torque CT 20:1	FS 360-445	--

1) Group as option (M32)



SIMOTICS Explosion Proof Motors

Frame and End Shields

The SIMOTICS Explosion Proof motors, XP100 and XP100 ID1, feature cast iron frame, end shields and an easy-to-access diagonally split, oversize terminal box; the terminal box is provided with a neoprene gasket and includes a heavy-duty ground lug and non-wicking clearly and permanently marked leads. These characteristics, its high strength, zinc-plated hardware, epoxy paint, and stainless steel nameplate provide exceptional structural integrity and resistance to rust and corrosion, making them suitable for severe duty applications in harsh environments

Rotor and Stator Windings

A unique offset rotor bar design provides improved efficiency, while larger bars and end rings reduce resistance for lower rotor losses. Each die cast aluminum rotor assembly is dynamically balanced for extended bearing life and includes a high-strength carbon steel (C1045) shaft for maximum rotor performance.

The stator is manufactured with premium electrical C5 grade steel lamination and copper electrical magnet wire that furthers the reduction in losses.

Insulation

The proprietary Class F non-hygroscopic insulation system, NEMA Class B temperature rise, provides an extra margin of thermal life. The varnish system application ensures maximum wire penetration to provide protection from moisture, corrosion and electrical shock. This insulation system meets or exceeds NEMA MG1 2014 Part 31, making the motors suitable for variable speed drives in constant torque (4:1) and variable torque (20:1). All windings are tested for CIV.

Cooling System

A non-sparking, bi-directional fan is locked and keyed to the shaft. Its low-inertia design reduces windage losses, improves airflow, reduces noise and provides dependable cooling. Cast Iron fan covers are provided for all frames sizes.

Bearings

Single shielded bearings are used for better bearing protection against contaminants.



SIMOTICS Explosion Proof Motors

XP100

XP100 (Cast Iron Frame) Rotor: Die Cast Aluminum Eff: NEMA Premium				Delivery Category:				Stock	Quick Mod	Custom Build	
Class I, Groups C&D, Class II, Groups F&G, Division 1											
Power HP	Speed Rpm	NEMA Frame	Base Part Number	Voltage	Digits 12-13			Digits 14,15,16		Eff	Weight Lbs
					Foot Mounted w Protection ³⁾			C - Face w/o feet w/drip cover & lifting w Protection ^{3),4)}			
					1-4AG3	1-6AG3	1-2AG3	1-6LG3			
■ - ■■■■ = digits 12-13,14,15,16				List Price \$							
1	1800	143T	1MB2121-1AB2 ■■■■	230/460*	862	--	--	1,076	85.5%	77	
1	1200	145T	1MB2121-1AC3 ■■■■	230/460*	1,014	--	--	1,228	82.5%	88	
1	900	182T	1MB2121-1CD1 ■■■■	230/460*	1,874	--	--	2,111	81.5%	100	
1 1/2	3600	143T	1MB2121-1AA2 ■■■■	230/460*	905	--	--	1,119	84.0%	55	
1 1/2	1800	145T	1MB2121-1AB3 ■■■■	230/460*	927	--	--	1,141	86.5%	88	
1 1/2	1200	182T	1MB2121-1CC1 ■■■■	230/460*	1,106	--	--	1,343	87.5%	105	
1 1/2	900	184T	1MB2121-1CD3 ■■■■	230/460*	2,206	--	--	2,443	82.5%	125	
2	3600	145T	1MB2121-1AA3 ■■■■	230/460*	1,028	--	--	1,242	85.5%	65	
2	1800	145T	1MB2121-1AB4 ■■■■	230/460*	990	--	--	1,204	86.5%	88	
2	1200	184T	1MB2121-1CC3 ■■■■	230/460*	1,249	--	--	1,486	88.5%	125	
2	900	213T	1MB2121-2AD1 ■■■■	230/460*	2,639	--	--	2,878	84.0%	161	
3	3600	182T	1MB2121-1CA1 ■■■■	230/460*	1,123	--	--	1,360	86.5%	88	
3	1800	182T	1MB2121-1CB1 ■■■■	230/460*	1,115	--	--	1,352	89.5%	110	
3	1200	213T	1MB2121-2AC1 ■■■■	230/460*	1,522	--	--	1,761	89.5%	173	
3	900	215T	1MB2121-2AD2 ■■■■	230/460*	3,170	--	--	3,409	85.5%	173	
5	3600	184T	1MB2121-1CA3 ■■■■	230/460*	1,502	--	--	1,739	88.5%	105	
5	1800	184T	1MB2121-1CB3 ■■■■	230/460*	1,366	--	--	1,603	89.5%	125	
5	1200	215T	1MB2121-2AC2 ■■■■	230/460*	2,171	--	--	2,410	89.5%	180	
5	900	254T	1MB2121-2BD1 ■■■■	230/460*	3,616	--	--	3,934	86.5%	270	
7 1/2	3600	213T	1MB2121-2AA1 ■■■■	230/460*	1,695	--	--	1,934	89.5%	165	
7 1/2	1800	213T	1MB2121-2AB1 ■■■■	230/460*	1,680	--	--	1,919	91.7%	185	
7 1/2	1200	254T	1MB2121-2BC1 ■■■■	230/460*	2,627	--	--	2,945	91.0%	285	
7 1/2	900	256T	1MB2121-2BD2 ■■■■	230/460*	4,131	--	--	4,449	87.5%	300	
10	3600	215T	1MB2121-2AA2 ■■■■	230/460*	1,965	--	--	2,204	90.2%	173	
10	1800	215T	1MB2121-2AB2 ■■■■	230/460*	1,995	--	--	2,234	91.7%	187	
10	1200	256T	1MB2121-2BC2 ■■■■	230/460*	3,188	--	--	3,506	91.0%	308	
10	900	284T	1MB2121-2CD1 ■■■■	230/460	--	5,124	--	6,230	90.2%	486	
15	3600	254T	1MB2121-2BA1 ■■■■	230/460*	2,671	--	--	2,989	91.0%	283	
15	1800	254T	1MB2121-2BB1 ■■■■	230/460*	2,623	--	--	2,941	92.4%	303	
15	1200	284T	1MB2121-2CC1 ■■■■	230/460	--	4,415	--	4,888	91.7%	481	
15	900	286T	1MB2121-2CD2 ■■■■	230/460	--	6,574	--	7,680	91.0%	531	
20	3600	256T	1MB2121-2BA2 ■■■■	230/460*	3,296	--	--	3,614	91.0%	308	
20	1800	256T	1MB2121-2BB2 ■■■■	230/460*	3,252	--	--	3,570	93.0%	340	
20	1200	286T	1MB2121-2CC2 ■■■■	230/460	--	5,387	--	6,493	91.7%	506	
20	900	324T	1MB2121-3AD1 ■■■■	230/460	--	8,482	--	9,806	91.0%	636	
25	3600	284TS ²⁾	1MB2121-2DA1 ■■■■	230/460	--	4,075	--	5,181	91.7%	526	
25	1800	284T	1MB2121-2CB1 ■■■■	230/460	--	3,912	--	5,018	93.6%	501	
25	1200	324T	1MB2121-3AC1 ■■■■	230/460	--	6,500	--	7,824	93.0%	713	
25	900	326T	1MB2121-3AD2 ■■■■	230/460	--	9,885	--	11,209	91.0%	683	
30	3600	286TS ²⁾	1MB2121-2DA2 ■■■■	230/460	--	4,757	--	5,863	91.7%	521	
30	1800	286T	1MB2121-2CB2 ■■■■	230/460	--	4,546	--	5,652	93.6%	521	
30	1200	326T	1MB2121-3AC2 ■■■■	230/460	--	7,518	--	8,842	93.0%	678	
30	900	364T	1MB2121-3CD1 ■■■■	230/460	--	10,420	--	12,327	91.7%	860	

*Suitable for 208V 1) CW Rotation facing opposite DE; 2) NEMA design A; 3) MLFB 15th digit 'G' = Thermostats, normally closed 1 per Phase; 4) MLFB 12 and 13 digits '16' = 240/460V; Note - 'R' before the frame designates the motor has Roller bearings
NEMA Premium is a certification mark of the National Electrical Manufacturer's Association.
QuikMOD Delivery is for stocked motors only.



Introduction
Special Features
Motor Selection and Pricing
Special Features Details
Typical Performance Details
General Dimensions
MV449 Frame
Indexes

SIMOTICS Explosion Proof Motors

XP100 (Continued)

XP100 (Cast Iron Frame) Rotor: Die Cast Aluminum Eff: NEMA Premium					Delivery Category:				Stock	Quick Mod	Custom Build
Class I, Groups C&D, Class II, Groups F&G, Division 1											
Power HP	Speed Rpm	NEMA Frame	Base Part Number	Voltage	Digits 12-13			Digits 14,15,16		Eff	Weight Lbs
					Foot Mounted w Protection ³⁾			C - Face w/o feet w/drip cover & lifting w Protection ^{3),4)}			
					1-4AG3	1-6AG3	1-2AG3	1-6LG3			
■ - ■■■■ = digits 12-13,14,15,16				List Price \$							
40	3600	324TS ²⁾	1MB2121-3BA1 ■■■■	230/460	--	6,044	--	7,368	93.6%	606	
40	1800	324T	1MB2121-3AB1 ■■■■	230/460	--	5,813	--	7,137	94.1%	653	
40	1200	364T	1MB2121-3CC1 ■■■■	230/460	--	9,692	--	11,599	94.1%	835	
40	900	365T	1MB2121-3CD2 ■■■■	230/460	--	10,319	--	12,226	91.7%	940	
50	3600	326TS ²⁾	1MB2121-3BA2 ■■■■	230/460	--	7,708	--	9,032	93.6%	615	
50	1800	326T	1MB2121-3AB2 ■■■■	230/460	--	7,081	--	8,405	94.5%	695	
50	1200	365T	1MB2121-3CC2 ■■■■	230/460	--	11,191	--	13,098	94.1%	870	
50	900	404T	1MB2121-4AD1 ■■■■	230/460	--	15,978	--	18,500	92.4%	1050	
60	3600	364TS ²⁾	1MB2121-3DA1 ■■■■	230/460	--	9,349	--	11,256	93.6%	790	
60	1800	364T	1MB2121-3CB1 ■■■■	230/460	--	9,248	--	11,155	95.0%	890	
60	1200	404T	1MB2121-4AC1 ■■■■	230/460	--	12,420	--	14,942	94.5%	1055	
60	900	405T	1MB2121-4AD2 ■■■■	230/460	--	18,166	--	20,688	92.4%	1050	
75	3600	365TS ²⁾	1MB2121-3DA2 ■■■■	230/460	--	11,400	--	13,307	94.1%	900	
75	1800	365T	1MB2121-3CB2 ■■■■	230/460	--	11,369	--	13,276	95.4%	960	
75	1200	405T	1MB2121-4AC2 ■■■■	230/460	--	14,263	--	16,785	94.5%	1025	
75	900	R444T	1MB2121-4CD1 ■■■■	230/460	--	22,527	--	--	93.6%	1551	
100	3600	405TS ²⁾	1MB2121-4BA2 ■■■■	230/460	--	16,053	--	18,575	94.1%	1020	
100	1800	405T	1MB2121-4AB2 ■■■■	230/460	--	14,902	--	17,424	95.4%	1115	
100	1200	R444T	1MB2121-4CC1 ■■■■	230/460	--	20,680	--	--	95.0%	1551	
100	900	R445T	1MB2121-4CD2 ■■■■	230/460	--	23,716	--	--	94.1%	1770	
125	3600	444TS ²⁾	1MB2121-4DA1 ■■■■	460	--	--	19,573	--	95.0%	1450	
125	1800	R444T	1MB2121-4CB1 ■■■■	460	--	--	18,889	--	95.4%	1659	
125	1800	444TS ²⁾	1MB2121-4DB1 ■■■■	460	--	--	18,281	--	95.4%	1596	
125	1800	444T	1MB2121-4EB1 ■■■■	460	--	--	18,281	--	95.4%	1621	
125	1200	R445T	1MB2121-4CC2 ■■■■	460	--	--	23,252	--	95.0%	1771	
125	900	R447T	1MB2121-4CD3 ■■■■	460	--	--	32,404	--	94.1%	2029	
150	3600	445TS ²⁾	1MB2121-4DA2 ■■■■	460	--	--	24,048	--	95.0%	1611	
150	1800	R445T	1MB2121-4CB2 ■■■■	460	--	--	22,391	--	95.8%	1934	
150	1800	445TS ²⁾	1MB2121-4DB2 ■■■■	460	--	--	21,783	--	95.8%	1706	
150	1800	445T	1MB2121-4EB2 ■■■■	460	--	--	21,783	--	95.8%	1896	
150	1200	R447T	1MB2121-4CC3 ■■■■	460	--	--	26,725	--	95.8%	2029	
150	900	R449T	1MB2121-4CD5 ■■■■	460	--	--	36,954	--	94.1%	2508	
200	3600	447TS ²⁾	1MB2121-4DA3 ■■■■	460	--	--	30,713	--	95.4%	2250	
200	1800	R447T	1MB2121-4CB3 ■■■■	460	--	--	27,448	--	96.2%	2314	
200	1800	447TS ²⁾	1MB2121-4DB3 ■■■■	460	--	--	26,840	--	96.2%	2250	
200	1800	447T	1MB2121-4EB3 ■■■■	460	--	--	26,840	--	96.2%	2276	
200	1200	R449T	1MB2121-4CC5 ■■■■	460	--	--	31,759	--	95.8%	2450	
200	1200	449T	1MB2121-4EC5 ■■■■	460	--	--	31,151	--	95.8%	2440	
200	900	R449T	1MB2121-4CD6 ■■■■	460	--	--	39,665	--	94.5%	2450	

* Suitable for 208V 1) CW Rotation facing opposite DE; 2) NEMA design A; 3) MLFB 15th digit 'G' = Thermostats, normally closed 1 per Phase; 4) MLFB 12 and 13 digits '16' = 240/460V; Note - 'R' before the frame designates the motor has Roller bearings
 NEMA Premium is a certification mark of the National Electrical Manufacturer's Association.
 QuikMOD Delivery is for stocked motors only.



SIMOTICS Explosion Proof Motors

XP100 (Continued)

XP100 (Cast Iron Frame) Rotor: Die Cast Aluminum Eff: NEMA Premium				Delivery Category:				Stock	Quick Mod	Custom Build
Class I, Groups C&D, Class II, Groups F&G, Division 1										
Power HP	Speed Rpm	NEMA Frame	Base Part Number	Digits 12-13	Digits 14,15,16			Eff	Weight Lbs	
				Voltage	Foot Mounted w Protection ³⁾		C - Face w/o feet w/drip cover & lifting w Protection ^{3),4)}			
					1-4AG3	1-6AG3	1-2AG3			1-6LG3
■ - ■■■■ = digits 12-13,14,15,16				List Price \$						
250	3600	449TS ²⁾	1MB2121-4DA5 ■■■■	460	--	--	37,573	95.8%	2300	
250	1800	R449T ²⁾	1MB2121-4CB5 ■■■■	460	--	--	32,881	96.2%	2453	
250	1800	449TS ²⁾	1MB2121-4DB5 ■■■■	460	--	--	32,273	96.2%	2453	
250	1800	449T ²⁾	1MB2121-4EB5 ■■■■	460	--	--	32,273	96.2%	2453	
250	1200	449TS ²⁾	1MB2121-4DC6 ■■■■	460	--	--	38,095	95.8%	2400	
300	3600	449TS ²⁾	1MB2121-4DA6 ■■■■	460	--	--	55,226	95.8%	2300	
300	1800	R449T ²⁾	1MB2121-4CB6 ■■■■	460	--	--	42,083	96.2%	2350	
300	1800	449T ²⁾	1MB2121-4EB6 ■■■■	460	--	--	41,475	96.2%	2315	
300	1800	449TS ²⁾	1MB2121-4DB6 ■■■■	460	--	--	41,475	96.2%	2315	

*Suitable for 208V 1) CW Rotation facing opposite DE; 2) NEMA design A; 3) MLFB 15th digit 'G' = Thermostats, normally closed 1 per Phase; 4) MLFB 12 and 13 digits '16' = 240/460V; Note - 'R' before the frame designates the motor has Roller bearings
NEMA Premium is a certification mark of the National Electrical Manufacturer's Association.
QuikMOD Delivery is for stocked motors only.



SIMOTICS Explosion Proof Motors

XP100 575

XP100 (Cast Iron Frame) Rotor: Die Cast Aluminum Eff: NEMA Premium					Delivery Category:	Stock	Quick Mod	Custom Build
					Class I, Groups C&D, Class II, Groups F&G, Division 1			
Power HP	Speed Rpm	NEMA Frame	Base Part Number	Voltage	Digits 14,15,16	Eff	Weight Lbs	
					Foot Mounted w/ Protection ³⁾			
					AG3			
					List Price \$			
1	1800	143T	1MB2121-1AB21-3AG3	575	862	85.5%	77	
1	1200	145T	1MB2121-1AC31-3AG3	575	1,014	82.5%	88	
1	900	182T	1MB2121-1CD11-3AG3	575	1,874	81.5%	100	
1 1/2	3600	143T	1MB2121-1AA21-3AG3	575	905	84.0%	55	
1 1/2	1800	145T	1MB2121-1AB31-3AG3	575	927	86.5%	88	
1 1/2	1200	182T	1MB2121-1CC11-3AG3	575	1,106	87.5%	105	
1 1/2	900	184T	1MB2121-1CD31-3AG3	575	2,206	82.5%	125	
2	3600	145T	1MB2121-1AA31-3AG3	575	1,028	85.5%	65	
2	1800	145T	1MB2121-1AB41-3AG3	575	990	86.5%	88	
2	1200	184T	1MB2121-1CC31-3AG3	575	1,249	88.5%	125	
2	900	213T	1MB2121-2AD11-3AG3	575	2,639	84.0%	161	
3	3600	182T	1MB2121-1CA11-3AG3	575	1,123	86.5%	88	
3	1800	182T	1MB2121-1CB11-3AG3	575	1,115	89.5%	110	
3	1200	213T	1MB2121-2AC11-3AG3	575	1,522	89.5%	173	
3	900	215T	1MB2121-2AD21-3AG3	575	3,170	85.5%	173	
5	3600	184T	1MB2121-1CA31-3AG3	575	1,502	88.5%	105	
5	1800	184T	1MB2121-1CB31-3AG3	575	1,366	89.5%	125	
5	1200	215T	1MB2121-2AC21-3AG3	575	2,171	89.5%	180	
5	900	254T	1MB2121-2BD11-3AG3	575	3,616	86.5%	270	
7 1/2	3600	213T	1MB2121-2AA11-3AG3	575	1,695	89.5%	165	
7 1/2	1800	213T	1MB2121-2AB11-3AG3	575	1,680	91.7%	185	
7 1/2	1200	254T	1MB2121-2BC11-3AG3	575	2,627	91.0%	285	
7 1/2	900	256T	1MB2121-2BD21-3AG3	575	4,131	87.5%	300	
10	3600	215T	1MB2121-2AA21-3AG3	575	1,965	90.2%	173	
10	1800	215T	1MB2121-2AB21-3AG3	575	1,995	91.7%	187	
10	1200	256T	1MB2121-2BC21-3AG3	575	3,188	91.0%	308	
10	900	284T	1MB2121-2CD11-3AG3	575	5,124	90.2%	486	
15	3600	254T	1MB2121-2BA11-3AG3	575	2,671	91.0%	283	
15	1800	254T	1MB2121-2BB11-3AG3	575	2,623	92.4%	303	
15	1200	284T	1MB2121-2CC11-3AG3	575	4,415	91.7%	481	
15	900	286T	1MB2121-2CD21-3AG3	575	6,574	91.0%	531	
20	3600	256T	1MB2121-2BA21-3AG3	575	3,296	91.0%	308	
20	1800	256T	1MB2121-2BB21-3AG3	575	3,252	93.0%	340	
20	1200	286T	1MB2121-2CC21-3AG3	575	5,387	91.7%	506	
20	900	324T	1MB2121-3AD11-3AG3	575	8,482	91.0%	636	
25	3600	284TS	1MB2121-2DA11-3AG3	575	4,075	91.7%	526	
25	1800	284T	1MB2121-2CB11-3AG3	575	3,912	93.6%	501	
25	1200	324T	1MB2121-3AC11-3AG3	575	6,500	93.0%	713	
25	900	326T	1MB2121-3AD21-3AG3	575	9,885	91.0%	683	

1) CW Rotation facing opposite DE; 2) NEMA design A; 3) MLFB 15th digit 'G' = Thermostats, normally closed 1 per Phase;

Note - 'R' before the frame designates the motor has Roller bearings

NEMA Premium is a certification mark of the National Electrical Manufacturer's Association.

QuikMOD Delivery is for stocked motors only.



SIMOTICS Explosion Proof Motors

XP100 575 (Continued)

XP100 (Cast Iron Frame) Rotor: Die Cast Aluminum Eff: NEMA Premium					Delivery Category:	Stock	Quick Mod	Custom Build
					Class I, Groups C&D, Class II, Groups F&G, Division 1			
Power HP	Speed Rpm	NEMA Frame	Base Part Number	Voltage	Digits 14,15,16		Eff	Weight Lbs
					Foot Mounted w/ Protection ³⁾			
					AG3			
					List Price \$			
30	3600	286TS	1MB2121-2DA21-3AG3	575	4,757		91.7%	521
30	1800	286T	1MB2121-2CB21-3AG3	575	4,546		93.6%	521
30	1200	326T	1MB2121-3AC21-3AG3	575	7,518		93.0%	678
30	900	364T	1MB2121-3CD11-3AG3	575	10,420		91.7%	860
40	3600	324TS	1MB2121-3BA11-3AG3	575	6,044		93.6%	606
40	1800	324T	1MB2121-3AB11-3AG3	575	5,813		94.1%	653
40	1200	364T	1MB2121-3CC11-3AG3	575	9,692		94.1%	835
40	900	365T	1MB2121-3CD21-3AG3	575	10,319		91.7%	940
50	3600	326TS	1MB2121-3BA21-3AG3	575	7,708		93.6%	615
50	1800	326T	1MB2121-3AB21-3AG3	575	7,081		94.5%	695
50	1200	365T	1MB2121-3CC21-3AG3	575	11,191		94.1%	870
50	900	404T	1MB2121-4AD11-3AG3	575	15,978		92.4%	1050
60	3600	364TS	1MB2121-3DA11-3AG3	575	9,349		93.6%	790
60	1800	364T	1MB2121-3CB11-3AG3	575	9,248		95.0%	890
60	1200	404T	1MB2121-4AC11-3AG3	575	12,420		94.5%	1055
60	900	405T	1MB2121-4AD21-3AG3	575	18,166		92.4%	1050
75	3600	365TS	1MB2121-3DA21-3AG3	575	11,400		94.1%	900
75	1800	365T	1MB2121-3CB21-3AG3	575	11,369		95.4%	960
75	1200	405T	1MB2121-4AC21-3AG3	575	14,263		94.5%	1025
75	900	444T	1MB2121-4CD11-3AG3	575	22,527		93.6%	1551
100	3600	405TS	1MB2121-4BA21-3AG3	575	16,053		94.1%	1020
100	1800	405T	1MB2121-4AB21-3AG3	575	14,902		95.4%	1115
100	1200	444T	1MB2121-4CC11-3AG3	575	20,680		95.0%	1551
100	900	445T	1MB2121-4CD21-3AG3	575	23,716		94.1%	1770
125	3600	444TS	1MB2121-4DA11-3AG3	575	19,573		95.0%	1450
125	1800	444TS	1MB2121-4DB11-3AG3	575	18,281		95.4%	1596
125	1800	444T	1MB2121-4CB11-3AG3	575	18,889		95.4%	1659
125	1200	445T	1MB2121-4CC21-3AG3	575	23,252		95.0%	1771
125	900	447T	1MB2121-4CD31-3AG3	575	32,404		94.1%	2029
150	3600	445TS	1MB2121-4DA21-3AG3	575	24,048		95.0%	1611
150	1800	445TS	1MB2121-4DB21-3AG3	575	21,783		95.8%	1706
150	1800	445T	1MB2121-4CB21-3AG3	575	22,391		95.8%	1934
150	1200	447T	1MB2121-4CC31-3AG3	575	26,725		95.8%	2029
150	900	449T	1MB2121-4CD51-3AG3	575	36,954		94.1%	2508

1) CW Rotation facing opposite DE; 2) NEMA design A; 3) MLFB 15th digit 'G' = Thermostats, normally closed 1 per Phase;
 Note - 'R' before the frame designates the motor has Roller bearings
 NEMA Premium is a certification mark of the National Electrical Manufacturer's Association.
 QuikMOD Delivery is for stocked motors only.



SIMOTICS Explosion Proof Motors

XP100 575 (Continued)

XP100 (Cast Iron Frame) Rotor: Die Cast Aluminum Eff: NEMA Premium					Delivery Category:		Stock	
							Quick Mod	
					Class I, Groups C&D, Class II, Groups F&G, Division 1			
Power HP	Speed Rpm	NEMA Frame	Base Part Number	Voltage	Digits 14,15,16		Eff	Weight Lbs
					Foot Mounted w/ Protection ³⁾			
					AG3			
					List Price \$			
200	3600	447TS	1MB2121-4DA31-3AG3	575	30,713		95.4%	2250
200	1800	447TS	1MB2121-4DB31-3AG3	575	26,840		96.2%	2250
200	1800	447T	1MB2121-4CB31-3AG3	575	27,448		96.2%	2314
200	1200	449T	1MB2121-4CC51-3AG3	575	31,759		95.8%	2450
200	900	449T	1MB2121-4CD61-3AG3	575	39,665		94.5%	2450
250	3600	449TS	1MB2121-4DA51-3AG3	575	37,573		95.8%	2300
250	1800	449TS	1MB212-14DB51-3AG3	575	32,273		96.2%	2453
250	1200	449TS	1MB2121-4DC61-3AG3	575	38,095		95.8%	2400
300	3600	449TS	1MB2121-4DA61-3AG3	575	55,226		95.8%	2300
300	1800	449TS	1MB2121-4DB61-3AG3	575	41,475		96.2%	2315

1) CW Rotation facing opposite DE; 2) NEMA design A; 3) MLFB 15th digit 'G' = Thermostats, normally closed 1 per Phase;

Note - 'R' before the frame designates the motor has Roller bearings

NEMA Premium is a certification mark of the National Electrical Manufacturer's Association.

QuikMOD Delivery is for stocked motors only.



SIMOTICS Explosion Proof Motors

XP100 ID1

XP100 ID1 (Cast Iron Frame) Rotor: Die Cast Aluminum Eff: NEMA Premium					Delivery Category:				Stock	Quick Mod	Custom Build
					Class I, Group D, Division 1						
Power HP	Speed Rpm	NEMA Frame	Base Part Number	Digits 12-13	Digits 14,15,16				Eff	Weight Lbs	
				Voltage	Foot Mounted w/o Protection ³⁾			C - Face w/o feet w/o Protection ⁴⁾			
					1-4AA3	1-6AA3	1-2AA3	1-6GA3			
■ - ■■■■■ = digits 12-13,14,15,16				List Price \$							
2	1800	145T	1MB2221-1AB2 ■■■■■	230/460*	779	--	--	869	85.5%	77	
3	1800	182T	1MB2221-1AC3 ■■■■■	230/460*	905	--	--	1,228	82.5%	88	
5	1800	184T	1MB2221-1AA2 ■■■■■	230/460*	810	--	--	2,111	84.0%	55	
7 1/2	1800	213T	1MB2221-1AB3 ■■■■■	230/460*	833	--	--	923	86.5%	88	
10	1800	215T	1MB2221-1CC1 ■■■■■	230/460*	984	--	--	1,141	87.5%	105	
15	1800	254T	1MB2221-1AA3 ■■■■■	230/460*	918	--	--	1,343	85.5%	65	
20	1800	256T	1MB2221-1AB4 ■■■■■	230/460*	888	--	--	978	86.5%	88	
25	1800	284T	1MB2221-1CC3 ■■■■■	230/460*	1,108	--	--	1,242	88.5%	125	
30	1800	286T	1MB2221-1CA1 ■■■■■	230/460*	999	--	--	1,204	86.5%	88	
40	1800	324T	1MB2221-1CB1 ■■■■■	230/460*	995	--	--	1,127	89.5%	110	
50	1800	326T	1MB2221-2AC1 ■■■■■	230/460*	1,345	--	--	2,878	89.5%	173	
60	1800	364T	1MB2221-1CA3 ■■■■■	230/460*	1,326	--	--	1,360	88.5%	105	
75	1800	365T	1MB2221-1CB3 ■■■■■	230/460*	1,211	--	--	1,343	89.5%	125	
100	1800	405T	1MB2221-2AC2 ■■■■■	230/460*	1,903	--	--	1,761	89.5%	180	
125	1800	444T	1MB2221-2AA1 ■■■■■	230/460*	1,489	--	--	3,409	89.5%	165	
125	1800	444T	1MB2221-2AB1 ■■■■■	230/460*	1,481	--	--	1,613	91.7%	185	
150	1800	445T	1MB2221-2BC1 ■■■■■	230/460*	2,292	--	--	1,603	91.0%	285	
150	1800	445T	1MB2221-2AA2 ■■■■■	230/460*	1,717	--	--	2,410	90.2%	173	
10	1800	215T	1MB2221-2AB2 ■■■■■	230/460*	1,750	--	--	1,882	91.7%	187	
10	1200	256T	1MB2221-2BC2 ■■■■■	230/460*	2,767	--	--	1,934	91.0%	308	
15	3600	254T	1MB2221-2BA1 ■■■■■	230/460*	2,322	--	--	1,919	91.0%	283	
15	1800	254T	1MB2221-2BB1 ■■■■■	230/460*	2,290	--	--	2,470	92.4%	303	
15	1200	284T	1MB2221-2CC1 ■■■■■	230/460	--	3,814	--	4,449	91.7%	481	
20	3600	256T	1MB2221-2BA2 ■■■■■	230/460*	2,857	--	--	2,204	91.0%	308	
20	1800	256T	1MB2221-2BB2 ■■■■■	230/460*	2,829	--	--	3,009	93.0%	340	
20	1200	286T	1MB2221-2CC2 ■■■■■	230/460	--	4,638	--	3,506	91.7%	506	
25	3600	284TS	1MB2221-2DA1 ■■■■■	230/460	--	3,526	--	4,465	91.7%	530	
25	1800	284T	1MB2221-2CB1 ■■■■■	230/460	--	3,396	--	4,335	93.6%	501	
25	1200	324T	1MB2221-3AC1 ■■■■■	230/460	--	5,584	--	2,941	93.0%	713	
30	3600	286TS	1MB2221-2DA2 ■■■■■	230/460	--	4,110	--	5,049	91.7%	525	
30	1800	286T	1MB2221-2CB2 ■■■■■	230/460	--	3,940	--	4,879	93.6%	521	
30	1200	326T	1MB2221-3AC2 ■■■■■	230/460	--	6,449	--	3,614	93.0%	678	
40	3600	324TS	1MB2221-3BA1 ■■■■■	230/460	--	5,211	--	3,570	93.6%	615	
40	1800	324T	1MB2221-3AB1 ■■■■■	230/460	--	5,028	--	6,057	94.1%	653	
40	1200	364T	1MB2221-3CC1 ■■■■■	230/460	--	8,296	--	9,604	94.1%	835	
50	3600	326TS	1MB2221-3BA2 ■■■■■	230/460	--	6,636	--	7,665	93.6%	615	
50	1800	326T	1MB2221-3AB2 ■■■■■	230/460	--	6,116	--	7,145	94.5%	687	
50	1200	365T	1MB2221-3CC2 ■■■■■	230/460	--	9,567	--	10,875	94.1%	870	
60	3600	364TS	1MB2221-3DA1 ■■■■■	230/460	--	8,675	--	9,983	93.6%	790	
60	1800	364T	1MB2221-3CB1 ■■■■■	230/460	--	8,611	--	9,919	95.0%	890	
60	1200	404T	1MB2221-4AC1 ■■■■■	230/460	--	11,445	--	13,129	94.5%	1055	

*Suitable for 208V 1) CW Rotation facing opposite DE; 2) NEMA design A; 3) MLFB 15th digit 'G' = Thermostats, normally closed 1 per Phase; 4) MLFB 12 and 13 digits '16' = 240/460V; Note - 'R' before the frame designates the motor has Roller bearings
NEMA Premium is a certification mark of the National Electrical Manufacturer's Association.
QuikMOD Delivery is for stocked motors only.



SIMOTICS Explosion Proof Motors

XP100 ID1 (Continued)

XP100 ID1 (Cast Iron Frame) Rotor: Die Cast Aluminum Eff: NEMA Premium					Delivery Category:				Stock	Quick Mod	Custom Build
					Class I, Group D, Division 1						
Power HP	Speed Rpm	NEMA Frame	Base Part Number	Digits 12-13	Digits 14,15,16				Eff	Weight Lbs	
				Voltage	Foot Mounted w/o Protection ³⁾			C - Face w/o feet w/o Protection ⁴⁾			
					1-4AA3	1-6AA3	1-2AA3	1-6GA3			
■ - ■■■■ = digits 12-13,14,15,16				List Price \$							
75	3600	365TS	1MB2221-3DA2 ■■■■	230/460	--	10,490	--	11,798	94.1%	900	
75	1800	365T	1MB2221-3CB2 ■■■■	230/460	--	10,498	--	11,806	95.4%	960	
75	1200	405T	1MB2221-4AC2 ■■■■	230/460	--	13,033	--	14,717	94.5%	1025	
100	3600	405TS	1MB2221-4BA2 ■■■■	230/460	--	14,644	--	16,328	94.1%	1020	
100	1800	405T	1MB2221-4AB21 ■■■■	230/460	--	13,641	--	15,325	95.4%	1115	
100	1200	R444T	1MB2221-4CC1 ■■■■	230/460	--	18,789	--	21,092	95.0%	1551	
100	1200	444T	1MB2221-4EC1 ■■■■	230/460	--	18,181	--	--	95.0%	1513	
125	3600	444TS	1MB2221-4DA1 ■■■■	460	--	--	17,760	20,063	95.0%	1450	
125	1800	R444T	1MB2221-4CB1 ■■■■	460	--	--	17,254	--	95.4%	1659	
125	1800	444T	1MB2221-4EB1 ■■■■	460	--	--	16,646	18,949	95.4%	1621	
125	1200	R445T	1MB2221-4CC2 ■■■■	460	--	--	21,013	--	95.0%	1771	
125	1200	445T	1MB2221-4EC2 ■■■■	460	--	--	20,405	22,708	95.0%	1733	
150	3600	445TS	1MB2221-4DA2 ■■■■	460	--	--	21,743	24,046	95.0%	1611	
150	1800	R445T	1MB2221-4CB2 ■■■■	460	--	--	20,369	--	95.8%	1934	
150	1800	445T	1MB2221-4EB2 ■■■■	460	--	--	19,761	22,064	95.8%	1896	
150	1200	R447T	1MB2221-4CC3 ■■■■	460	--	--	24,055	--	95.8%	2029	
150	1200	447T	1MB2221-4EC3 ■■■■	460	--	--	23,447	25,750	95.8%	1991	
200	3600	447TS	1MB2221-4DA3 ■■■■	460	--	--	27,361	29,664	95.4%	2250	
200	1800	R447T	1MB2221-4CB3 ■■■■	460	--	--	24,601	--	96.2%	2314	
200	1800	447T	1MB2221-4EB3 ■■■■	460	--	--	23,993	26,296	96.2%	2276	
200	1200	R449T	1MB2221-4CC5 ■■■■	460	--	--	28,163	--	95.8%	2450	
200	1200	449T	1MB2221-4EC5 ■■■■	460	--	--	27,555	29,858	95.8%	2440	
250	3600	449TS	1MB2221-4DA5 ■■■■	460	--	--	32,434	34,737	95.8%	2300	
250	1800	R449T	1MB2221-4CB5 ■■■■	460	--	--	28,562	--	96.2%	2453	
250	1800	449T	1MB2221-4EB5 ■■■■	460	--	--	27,954	30,257	96.2%	2453	
300	3600	449TS	1MB2221-4DA6 ■■■■	460	--	--	41,503	43,806	95.8%	2300	
300	1800	R449T	1MB2221-4CB6 ■■■■	460	--	--	31,882	--	96.2%	2350	
300	1800	449T	1MB2221-4EB6 ■■■■	460	--	--	31,274	33,577	96.2%	2340	

*Suitable for 208V 1) CW Rotation facing opposite DE; 2) NEMA design A; 3) MLFB 15th digit 'G' = Thermostats, normally closed 1 per Phase; 4) MLFB 12 and 13 digits '16' = 240/460V; Note - 'R' before the frame designates the motor has Roller bearings
 NEMA Premium is a certification mark of the National Electrical Manufacturer's Association.
 QuikMOD Delivery is for stocked motors only.



SIMOTICS Explosion Proof Motors

XP100 ID1 575

XP100 ID1 (Cast Iron Frame) Rotor: Die Cast Aluminum Eff: NEMA Premium					Delivery Category:		Stock	Quick Mod	Custom Build
					Class I, Group D, Division 1				
Power HP	Speed Rpm	NEMA Frame	Base Part Number	Voltage	Digits 14,15,16		Eff	Weight Lbs	
					Foot Mounted w/ Protection ³⁾				
					AG3				
					List Price \$				
2	1800	145T	1MB2221-1AB41-3AA3	575	888		86.5%	88	
3	1800	182T	1MB2221-1CB11-3AA3	575	995		89.5%	110	
5	1800	184T	1MB2221-1CB31-3AA3	575	1,211		89.5%	125	
7 1/2	1800	213T	1MB2221-2AB11-3AA3	575	1,481		91.7%	185	
10	1800	215T	1MB2221-2AB21-3AA3	575	1,750		91.7%	187	
15	1800	254T	1MB2221-2BB11-3AA3	575	2,290		92.4%	303	
20	1800	256T	1MB2221-2BB21-3AA3	575	2,829		93.0%	340	
25	1800	284T	1MB2221-2CB11-3AA3	575	3,396		93.6%	501	
30	1800	286T	1MB2221-2CB21-3AA3	575	3,940		93.6%	521	
40	1800	324T	1MB2221-3AB11-3AA3	575	5,028		94.1%	653	
50	1800	326T	1MB2221-3AB21-3AA3	575	6,116		94.5%	687	
60	1800	364T	1MB2221-3CB11-3AA3	575	8,611		95.0%	890	
75	1800	365T	1MB2221-3CB21-3AA3	575	10,498		95.4%	960	
100	1800	405T	1MB2221-4AB21-3AA3	575	13,641		95.4%	1115	
125	1800	444T	1MB2221-4CB11-3AA3	575	17,254		95.4%	1659	
125	1800	444T	1MB2221-4EB11-3AA3	575	16,646		95.4%	1621	
150	1800	445T	1MB2221-4CB21-3AA3	575	20,369		95.8%	1934	
150	1800	445T	1MB2221-4EB21-3AA3	575	19,761		95.8%	1896	

1) CW Rotation facing opposite DE; 2) NEMA design A; 3) MLFB 15th digit 'G' = Thermostats, normally closed 1 per Phase;

Note - 'R' before the frame designates the motor has Roller bearings

NEMA Premium is a certification mark of the National Electrical Manufacturer's Association.

QuikMOD Delivery is for stocked motors only.



SIMOTICS Explosion Proof Motors

XP JP Frame Motors

JP XP100 & XP100 ID1 (Cast Iron Frame) Rotor: Die Cast Aluminum Eff: NEMA Premium					Delivery Category:		Stock	Quick Mod	Custom Build
XP 100 JP frame - Class 1, Groups C&D, Class II, Groups F&G, Division 1									
Power HP	Speed Rpm	NEMA Frame	Base Part Number	Voltage	Digits 14,15,16		Eff	Weight Lbs	
					CH - Flange w/ Feet w/ Protection*	C-Face w/ Feet w/ Protection*			
					WG3	EG3			
					List Price \$				
3	1800	182JP	1MB2121-1FB31-4 ■■■	230/460*	1719	--	89.5%	110	
5	1800	184JP	1MB2121-1FB41-4 ■■■	230/460*	1970	--	89.5%	125	
7.5	1800	213JP	1MB2121-2FB31-4 ■■■	230/460*	--	3101	91.7%	185	
10	1800	215JP	1MB2121-2FB41-4 ■■■	230/460*	--	3416	91.7%	187	

XP 100 JP frame - Class 1, Group D, Division 1									
Power HP	Speed Rpm	NEMA Frame	Base Part Number	Voltage	Digits 14,15,16		Eff	Weight Lbs	
					CH - Flange w/o Feet w/ Protection*	C-Face w Feet w/ Protection*			
					WA3	EA3			
					List Price \$				
3	1800	182JP	1MB2221-1FB31-4 ■■■	230/460*	1599	--	82.5%	88	
5	1800	184JP	1MB2221-1FB41-4 ■■■	230/460*	1815	--	84.0%	55	
7.5	1800	213JP	1MB2221-2FB31-4 ■■■	230/460*	--	2902	86.5%	88	
10	1800	215JP	1MB2221-2FB41-4 ■■■	230/460*	--	3171	87.5%	105	

* MLFB 15th Digit 'G' = Thermostats, normally closed 1 per Phase

**Suitable for 208V

NEMA Premium is a certification mark of the National Electrical Manufacturer's Association.

QuikMOD Delivery is for stocked motors only.



SIMOTICS Definite Purpose Motors



Introduction

Special Features

Motor Selection and Pricing

Special Features Details

Typical Performance Details







General Dimensions

MV449 Frame

Indexes

Introduction

Siemens Definite Purpose Motors are designed and built to operate under harsh environments in the industry, including but not limited to petrochemical, pulp and paper mills and waste-water treatment. In-line pumps, Booster, Centrifugal and Non-Clog pumps, Vertical Turbine, mix flow and propeller pumps are some of the many applications. Pump motors are design to meet or exceed the NEMA Premium® efficiency (MG1 Table 12-12) as well as the most stringent industry standards API610 (LP100) and IEEE 841 where applicable. DP200 HPS motors use the SD200 as a base with added features (Provisions for Bearing RTDs, Provisions for Vibration detectors, and Insulated NDE bearing) that are key in the Horizontal Pump Systems motors. SD10 MS motors are energy efficient motors build with the same characteristics of our Severe Duty line. A wide selection of options, among them bearing isolator and ceramic bearings on drive end, extra high thrust and Non-Reverse Ratchet for LP100 motors, make these motors suitable almost any requirement. The construction of these motors is backed up by its three year warranty and 5 years when order with IEEE841 features.

Performance Specification					
		Pump Motors			Multi-speed
		VSS Vertical Solid Shaft		HPS Horizontal Pump Systems	One Winding Variable
		LP100	HP100	DP200-HPS	SD10 MS
HP Range	3600 RPM	3-300 HP		FS 509-5013S	1-200HP 1800 / 900
	1800 RPM	3-250 HP		--	
	1200 RPM				
Frame Size	140T - 500	180LP - 440LP	180HP - 440HP	FS 509-5013S	143T-449T
Standard Voltage (3~ 60 Hz)	230V/460V	FS 180 - 250		--	--
	460V	FS 280 - 440		FS 509-5013S	FS 143-449
	575V	FS 180 - 440		FS 509-5013S	FS 143-449
Efficiency	NEMA Premium® (MG1-Table 12-12)	3 - 300 HP		FS 509-5013S	--
	Energy Efficient (MG 1-Table 12-11)	--		--	FS 143-449
Service Factor	1.15 @ 40°C	FS 180-440		FS 509-5013S	--
	1.00 @ 40°C	--		--	FS 143-449
Insulation	Non-Hygroscopic	Class F		Class F	Class F
Temperature Rise	Class B	@ 1.0SF		@ 1.0SF	@ 1.0SF
	Class F	@ 1.15SF		@ 1.15SF	@ 1.15SF
Conduit Box (Oversized)	Oversized	Cast Iron		Cast Iron	Cast Iron
Fan Cover		Cast Iron		Cast Iron	Cast Iron
Cooling Fan	Bi-Directional	Polypropylene		Polypropylene	Polypropylene
Rotor	Die Cast Aluminum	FS 180-440		FS 509-5013S	FS 143-449
Ingress Protection	NEMA	IP55		IP55	IP54
Hazardous Location	Gas	CL 1, Div 2 Gr. A,B,C or D Temp Code T3		CL 1, Div 2 Gr. A,B,C or D Temp Code T3	--
Inverter Duty	Variable Torque 20:1	FS 180-440		FS 509-5013S	--
	Constant Torque CT 4:1	FS 180-440		FS 509-5013S	--
	Constant Torque CT 2:1	--		3600 RPM	--
		     			



SIMOTICS Definite Purpose Motors

Frame and End Shields

Definite purpose motors feature cast iron frame, end shields and an easy to access, diagonally split, oversize terminal box; the terminal box is provided with a neoprene gasket and includes a heavy duty ground lug and non-wicking clearly and permanently marked leads. These characteristics, its zinc-plated hardware, epoxy paint and stainless steel nameplate provide exceptional structural integrity and resistant to rust and corrosion, and make them suitable for severe duty applications in harsh environments

Rotor and Stator Windings

A unique offset rotor bar design provides improved efficiency, while larger bars and end rings reduce resistance for lower rotor losses. Each die cast aluminum rotor assembly is dynamically balanced with half key for extended bearing life and includes a high-strength carbon steel (C1045) shaft for maximum rotor performance.

The stator is manufactured with premium electrical C5 grade steel lamination and copper electrical magnet wire that reduce losses.

Insulation

The proprietary Class F non-hygroscopic insulation system, NEMA Class B temperature rise, provides an extra margin of thermal life. The varnish system application ensures maximum wire penetration to provide protection from moisture, corrosion and electrical shock. This insulation system meets or exceeds NEMA MG1 2014 Part 31 making the motors suitable for variable speed drives in constant torque (4:1) and variable torque (20:1). All windings are tested for CIV.

Cooling System

A non-sparking, bi-directional fan is locked and keyed to the shaft. Its low-inertia design reduces windage losses, improves airflow, reduces noise and provides dependable cooling. Metal sheet fan covers are provided for all frames sizes.

Bearings

Definite purpose motors are provided with single shielded bearings, HP100 (DE and NDE) and LP100 (DE) include regreasable open ball bearings for up to 250HP and 250LP frames, The LP100 opposite drive end features a duplex angular contact thrust bearing, across all frames sizes, depending on the arrangement the motor can provide high thrust or up to 175% extra high thrust..



SIMOTICS Definite Purpose Motors

LP100

LP100 Vertical Solid Shaft (Cast Iron Frame) - High Thrust									Delivery Category		Stock	
Rotor: Die Cast Aluminum									Quick Mod		Custom Build	
Eff: NEMA Premium												
Power HP	Speed Rpm	NEMA Frame	Base Part Number	Voltage	List Price \$	FL Amps	Eff	Weight Lbs	High Thrust Lbs			
									Down Thrust	Up Thrust	Radial Thrust	
3	3600	182LP	1PC2832-1DA41-6TA3	230/460V	2,459	3.8	86.5	118	1087	1095	24	
5	3600	184LP	1PC2832-1DA51-6TA3	230/460V	2,717	6	88.5	130	1075	1082	34	
7.5	3600	213LP	1PC2832-2AA51-6TA3	230/460V	3,261	8.8	89.5	188	1860	1880	40	
10	3600	215LP	1PC2832-2AA61-6TA3	230/460V	3,652	11.5	90.2	202	1848	1868	50	
15	3600	254LP	1PC2832-2BA51-6TA3	230/460V	4,208	17.5	91	309	1811	1843	75	
20	3600	256LP	1PC2832-2BA61-6TA3	230/460V	4,722	22.5	91	337	1789	1824	92	
25	3600	284LPH	1PC2832-2EA11-2TA3	460V	5,247	29	91.7	559	2541	2593	65	
30	3600	286LPH	1PC2832-2EA41-2TA3	460V	5,567	34	91.7	591	2523	2578	78	
40	3600	324LP	1PC2832-3AA51-2TA3	460V	7,423	45	93.6	784	2480	2551	98	
50	3600	326LP	1PC2832-3AA61-2TA3	460V	9,095	55	93.6	799	2466	2535	105	
60	3600	364LP	1PC2832-3CA51-2TA3	460V	11,320	68	93.6	836	2386	2495	152	
75	3600	365LP	1PC2832-3CA61-2TA3	460V	13,799	86	94.1	877	2352	2465	175	
100	3600	405LP	1PC2832-4AA61-2TA3	460V	18,617	108	94.1	1057	2269	2406	230	
3	1800	182LP	1PC2832-1DB41-6TA3	230/460V	2,395	4	89.5	129	1361	1369	39	
5	1800	184LP	1PC2832-1DB51-6TA3	230/460V	2,568	6.5	89.5	135	1351	1357	45	
7.5	1800	213LP	1PC2832-2AB51-6TA3	230/460V	3,249	9.7	91.7	212	2328	2351	66	
10	1800	215LP	1PC2832-2AB61-6TA3	230/460V	3,655	12.5	91.7	220	2317	2338	73	
15	1800	254LP	1PC2832-2BB51-6TA3	230/460V	4,369	19	92.4	315	2279	2309	95	
20	1800	256LP	1PC2832-2BB61-6TA3	230/460V	4,977	25	93	342	2247	2281	120	
25	1800	284LPH	1PC2832-2EB11-2TA3	460V	5,163	30	93.6	640	3172	3233	108	
30	1800	286LPH	1PC2832-2EB41-2TA3	460V	5,808	35	93.6	649	3158	3217	116	
40	1800	324LP	1PC2832-3AB51-2TA3	460V	7,198	46	94.1	848	3093	3179	140	
50	1800	326LP	1PC2832-3AB61-2TA3	460V	8,446	58	94.5	957	3034	3135	180	
60	1800	364LP	1PC2832-3CB51-2TA3	460V	11,264	68	95	885	2965	3097	214	
75	1800	365LP	1PC2832-3CB61-2TA3	460V	13,843	85	95.4	948	2902	3046	255	
100	1800	405LP	1PC2832-4AB61-2TA3	460V	16,821	113	95.4	1059	2814	2976	303	
125	1800	444LP	1PC2832-4JB11-2TA3	460V	21,372	143	95.4	1429	2670	2911	347	
150	1800	445LP	1PC2832-4JB21-2TA3	460V	24,954	170	95.8	1565	2558	2835	417	
200	1800	447LP	1PC2832-4JB31-2TA3	460V	32,642	226	96.2	1843	2361	2703	524	
250	1800	449LP	1PC2832-4JB51-2TA3	460V	37,925	278	96.2	2203	2149	2571	638	
3	1200	213LP	1PC2832-2AC51-6TA3	230/460V	2,862	4.3	89.5	192	2702	2725	51	
5	1200	215LP	1PC2832-2AC61-6TA3	230/460V	3,723	6.7	89.5	204	2685	2705	62	
7.5	1200	254LP	1PC2832-2BC51-6TA3	230/460V	4,435	10	91	294	2648	2680	84	
10	1200	256LP	1PC2832-2BC61-6TA3	230/460V	5,008	13.5	91	310	2629	2659	98	
15	1200	284LPH	1PC2832-2EC11-6TA3	230/460V	5,611	21	91.7	601	3682	3738	95	
20	1200	286LPH	1PC2832-2EC41-6TA3	230/460V	6,607	27	91.7	656	3645	3705	120	
25	1200	324LP	1PC2832-3AC51-2TA3	460V	7,726	33	93	884	3569	3665	155	
30	1200	326LP	1PC2832-3AC61-2TA3	460V	8,636	39	93	920	3541	3640	172	
40	1200	364LP	1PC2832-3CC51-2TA3	460V	10,990	49	94.1	822	3494	3605	186	
50	1200	365LP	1PC2832-3CC61-2TA3	460V	12,931	62	94.1	855	3455	3565	208	
60	1200	404LP	1PC2832-4AC51-2TA3	460V	14,742	74	94.5	1021	3351	3500	274	
75	1200	405LP	1PC2832-4AC61-2TA3	460V	17,340	93	94.5	1088	3290	3444	310	
100	1200	444LP	1PC2832-4JC11-2TA3	460V	23,007	117	95	1385	3116	3364	353	
125	1200	445LP	1PC2832-4JC21-2TA3	460V	29,707	144	95	1565	2946	3254	455	
150	1200	447LP	1PC2832-4JC31-2TA3	460V	34,550	172	95.8	1778	2795	3161	529	
200	1200	449LP	1PC2832-4JC51-2TA3	460V	34,610	227	95.8	2204	2515	2985	673	
250	1200	449LP	1PC2832-4JC61-2TA3	460V	37,442	281	95.8	2191	2488	2904	679	

*Extra high thrust is available with option K21, refer to Technical Notes Section Bearing and Lubrication Table 6-2 for thrust values. NEMA Premium is a certification mark of the National Electrical Manufacturer's Association. QuikMOD Delivery is for stocked motors only.



SIMOTICS Definite Purpose Motors

LP100

LP100 Vertical Solid Shaft (Cast Iron Frame) - High Thrust									Delivery Category		Stock
Rotor: Die Cast Aluminum									Quick Mod		
Eff: NEMA Premium											Custom Build
Power HP	Speed Rpm	NEMA Frame	Base Part Number	Voltage	List Price \$	FL Amps	Eff	Weight Lbs	High Thrust Lbs		
									Down Thrust	Up Thrust	Radial Thrust
3	3600	182LP	1PC2832-1DA41-3TA3	575	2,459	3.8	86.5	118	1087	1095	24
5	3600	184LP	1PC2832-1DA51-3TA3	575	2,717	6	88.5	130	1075	1082	34
7.5	3600	213LP	1PC2832-2AA51-3TA3	575	3,261	8.8	89.5	188	1860	1880	40
10	3600	215LP	1PC2832-2AA61-3TA3	575	3,652	11.5	90.2	202	1848	1868	50
15	3600	254LP	1PC2832-2BA51-3TA3	575	4,208	17.5	91	309	1811	1843	75
20	3600	256LP	1PC2832-2BA61-3TA3	575	4,722	22.5	91	337	1789	1824	92
25	3600	284LPH	1PC2832-2EA11-3TA3	575	5,247	29	91.7	559	2541	2593	65
30	3600	286LPH	1PC2832-2EA41-3TA3	575	5,567	34	91.7	591	2523	2578	78
40	3600	324LP	1PC2832-3AA51-3TA3	575	7,423	45	93.6	784	2480	2551	98
50	3600	326LP	1PC2832-3AA61-3TA3	575	9,095	55	93.6	799	2466	2535	105
60	3600	364LP	1PC2832-3CA51-3TA3	575	11,320	68	93.6	836	2386	2495	152
75	3600	365LP	1PC2832-3CA61-3TA3	575	13,799	86	94.1	877	2352	2465	175
100	3600	405LP	1PC2832-4AA61-3TA3	575	18,617	108	94.1	1057	2269	2406	230
3	1800	182LP	1PC2832-1DB41-3TA3	575	2,395	4	89.5	129	1361	1369	39
5	1800	184LP	1PC2832-1DB51-3TA3	575	2,568	6.5	89.5	135	1351	1357	45
7.5	1800	213LP	1PC2832-2AB51-3TA3	575	3,249	9.7	91.7	212	2328	2351	66
10	1800	215LP	1PC2832-2AB61-3TA3	575	3,655	12.5	91.7	220	2317	2338	73
15	1800	254LP	1PC2832-2BB51-3TA3	575	4,369	19	92.4	315	2279	2309	95
20	1800	256LP	1PC2832-2BB61-3TA3	575	4,977	25	93	342	2247	2281	120
25	1800	284LPH	1PC2832-2EB11-3TA3	575	5,163	30	93.6	640	3172	3233	108
30	1800	286LPH	1PC2832-2EB41-3TA3	575	5,808	35	93.6	649	3158	3217	116
40	1800	324LP	1PC2832-3AB51-3TA3	575	7,198	46	94.1	848	3093	3179	140
50	1800	326LP	1PC2832-3AB61-3TA3	575	8,446	58	94.5	957	3034	3135	180
60	1800	364LP	1PC2832-3CB51-3TA3	575	11,264	68	95	885	2965	3097	214
75	1800	365LP	1PC2832-3CB61-3TA3	575	13,843	85	95.4	948	2902	3046	255
100	1800	405LP	1PC2832-4AB61-3TA3	575	16,821	113	95.4	1059	2814	2976	303
125	1800	444LP	1PC2832-4JB11-3TA3	575	21,372	143	95.4	1429	2670	2911	347
150	1800	445LP	1PC2832-4JB21-3TA3	575	24,954	170	95.8	1565	2558	2835	417
200	1800	447LP	1PC2832-4JB31-3TA3	575	32,642	226	96.2	1843	2361	2703	524
250	1800	449LP	1PC2832-4JB51-3TA3	575	37,925	278	96.2	2203	2149	2571	638
3	1200	213LP	1PC2832-2AC51-3TA3	575	2,862	4.3	89.5	192	2702	2725	51
5	1200	215LP	1PC2832-2AC61-3TA3	575	3,723	6.7	89.5	204	2685	2705	62
7.5	1200	254LP	1PC2832-2BC51-3TA3	575	4,435	10	91	294	2648	2680	84
10	1200	256LP	1PC2832-2BC61-3TA3	575	5,008	13.5	91	310	2629	2659	98
15	1200	284LPH	1PC2832-2EC11-3TA3	575	5,611	21	91.7	601	3682	3738	95
20	1200	286LPH	1PC2832-2EC41-3TA3	575	6,607	27	91.7	656	3645	3705	120
25	1200	324LP	1PC2832-3AC51-3TA3	575	7,726	33	93	884	3569	3665	155
30	1200	326LP	1PC2832-3AC61-3TA3	575	8,636	39	93	920	3541	3640	172
40	1200	364LP	1PC2832-3CC51-3TA3	575	10,990	49	94.1	822	3494	3605	186
50	1200	365LP	1PC2832-3CC61-3TA3	575	12,931	62	94.1	855	3455	3565	208
60	1200	404LP	1PC2832-4AC51-3TA3	575	14,742	74	94.5	1021	3351	3500	274
75	1200	405LP	1PC2832-4AC61-3TA3	575	17,340	93	94.5	1088	3290	3444	310
100	1200	444LP	1PC2832-4JC11-3TA3	575	23,007	117	95	1385	3116	3364	353
125	1200	445LP	1PC2832-4JC21-3TA3	575	29,707	144	95	1565	2946	3254	455
150	1200	447LP	1PC2832-4JC31-3TA3	575	34,550	172	95.8	1778	2795	3161	529
200	1200	449LP	1PC2832-4JC51-3TA3	575	34,610	227	95.8	2204	2515	2985	673
250	1200	449LP	1PC2832-4JC61-3TA3	575	37,442	281	95.8	2191	2488	2904	679

* Add '-Z' at the end of the base part number, and short code '+K21'

NEMA Premium is a certification mark of the National Electrical Manufacturer's Association.

QuikMOD Delivery is for stocked motors only.



SIMOTICS Definite Purpose Motors

HP100

HP100 Vertical Solid Shaft (Cast Iron Frame) - Normal Thrust									Delivery Category		Stock
Rotor: Die Cast Aluminum									Quick Mod		
Eff: NEMA Premium									Custom Build		
Power HP	Speed Rpm	NEMA Frame	Base Part Number	Voltage	List Price \$	FL Amps	Eff	Weight Lbs	Normal Thrust Lbs		
									Down Thrust	Up Thrust	Radial Thrust
3	3600	182HP	1PC2822-1DA11-6TA3	230/460V	1,852	3.8	86.5	118	901	908	24
3	1800	182HP	1PC2822-1DB11-6TA3	230/460V	1,635	4	89.5	129	1126	1134	39
3	1200	213HP	1PC2822-2AC31-6TA3	230/460V	2,536	4.3	89.5	192	2442	2413	51
5	3600	184HP	1PC2822-1DA21-6TA3	230/460V	2,596	6	88.5	130	889	896	34
5	1800	184HP	1PC2822-1DB21-6TA3	230/460V	2,276	6.5	89.5	135	1116	1122	45
5	1200	215HP	1PC2822-2AC41-6TA3	230/460V	3,571	6.7	89.5	204	2426	2413	62
7.5	3600	213HP	1PC2822-2AA31-6TA3	230/460V	3,130	8.8	89.5	188	1681	1699	40
7.5	1800	213HP	1PC2822-2AB31-6TA3	230/460V	3,119	9.7	91.7	211	2102	2123	66
7.5	1200	254HP	1PC2822-2BC31-6TA3	230/460V	4,258	10	91	294	2389	2413	86
10	3600	215HP	1PC2822-2AA41-6TA3	230/460V	3,506	11.5	90.2	202	1668	1688	52
10	1800	215HP	1PC2822-2AB41-6TA3	230/460V	3,509	12.5	91.7	220	2091	2111	75
10	1200	256HP	1PC2822-2BC41-6TA3	230/460V	4,810	13.5	91	310	2369	2399	100
15	3600	254HP	1PC2822-2BA31-6TA3	230/460V	4,042	17.5	91	309	1631	1664	76
15	1800	254HP	1PC2822-2BB31-6TA3	230/460V	4,192	19	92.4	315	2052	2082	97
15	1200	284HP	1PC2822-2CC31-6TA3	230/460V	5,608	21	91.7	494	2212	2258	97
20	3600	256HP	1PC2822-2BA41-6TA3	230/460V	4,420	22.5	91	337	1609	1643	94
20	1800	256HP	1PC2822-2BB41-6TA3	230/460V	4,779	25	93	342	2021	2052	122
20	1200	286HP	1PC2822-2CC41-6TA3	230/460V	6,815	27	91.7	551	2175	2226	120
25	3600	284HP	1PC2822-2CA31-2TA3	460V	4,425	29	91.7	454	1525	1567	66
25	1800	284HP	1PC2822-2CB31-2TA3	460V	4,957	30	93.6	535	1890	1940	109
25	1200	324HP	1PC2822-3AC31-2TA3	460V	7,420	33	93	773	2807	2906	169
30	3600	286HP	1PC2822-2CA41-2TA3	460V	4,790	34	91.7	486	1508	1552	78
30	1800	286HP	1PC2822-2CB41-2TA3	460V	5,576	35	93.6	544	1876	1923	117
30	1200	326HP	1PC2822-3AC41-2TA3	460V	8,472	39	93	809	2779	2879	187
40	3600	324HP	1PC2822-3AA31-2TA3	460V	6,576	45	93.6	674	1952	2025	106
40	1800	324HP	1PC2822-3AB31-2TA3	460V	6,642	46	94.1	737	2427	2514	153
40	1200	364HP	1PC2822-3CC31-2TA3	460V	11,091	49	94.1	802	3267	3388	187
50	3600	326HP	1PC2822-3AA41-2TA3	460V	8,249	55	93.6	689	1938	2007	114
50	1800	326HP	1PC2822-3AB41-2TA3	460V	7,876	58	94.5	846	2366	2468	196
50	1200	365HP	1PC2822-3CC41-2TA3	460V	13,076	62	94.1	835	3229	3348	208
60	3600	364HP	1PC2822-3CA31-2TA3	460V	10,498	68	93.6	817	2226	2345	153
60	1800	364HP	1PC2822-3CB31-2TA3	460V	10,442	68	95	865	2767	2908	215
60	1200	404HP	1PC2822-4AC31-2TA3	460V	14,911	74	94.5	1000	3125	3283	274
75	3600	365HP	1PC2822-3CA41-2TA3	460V	12,977	86	94.1	857	2192	2314	175
75	1800	365HP	1PC2822-3CB41-2TA3	460V	13,020	85	95.4	928	2703	2856	255
75	1200	405HP	1PC2822-4AC41-2TA3	460V	17,483	93	94.5	1068	3064	3227	310
100	3600	405HP	1PC2822-4AA41-2TA3	460V	17,288	108	94.1	1023	2110	2255	230
100	1800	405HP	1PC2822-4AB41-2TA3	460V	16,068	113	95.4	1073	2616	2786	304
100	1200	444HP	1PC2822-4HC11-2TA3	460V	23,373	117	95	1372	3479	3743	347
125	1800	444HP	1PC2822-4HB11-2TA3	460V	21,035	143	95.4	1419	2985	3243	342
125	1200	445HP	1PC2822-4HC21-2TA3	460V	28,254	144	95	1557	3310	3633	448
150	1800	445HP	1PC2822-4HB21-2TA3	460V	24,266	170	95.8	1559	2874	3166	411
150	1200	447HP	1PC2822-4HC31-2TA3	460V	35,111	172	95.8	1786	3160	3539	522
200	1800	447HP	1PC2822-4HB31-2TA3	460V	33,168	226	96.2	1854	2678	3035	516
200	1200	449HP	1PC2822-4HC51-2TA3	460V	40,004	227	95.8	2216	2880	3365	665
250	1800	449HP	1PC2822-4HB51-2TA3	460V	38,535	278	96.2	2246	2466	2903	631
250	1200	449HP	1PC2822-4HC61-2TA3	460V	43,994	281	95.8	2203	2853	3284	671

NEMA Premium is a certification mark of the National Electrical Manufacturer's Association.
 QuikMOD Delivery is for stocked motors only.



SIMOTICS Definite Purpose Motors

HP100 (Continued)

HP100 Vertical Solid Shaft (Cast Iron Frame) - Normal Thrust Rotor: Die Cast Aluminum Eff: NEMA Premium									Delivery Category		Stock
									Quick Mod		Custom Build
Power HP	Speed Rpm	NEMA Frame	Base Part Number	Voltage	List Price \$	FL Amps	Eff	Weight Lbs	Normal Thrust Lbs		
									Down Thrust	Up Thrust	Radial Thrust
3	3600	182HP	1PC2822-1DA11-3TA3	575	1,852	3.8	86.5	118	901	908	24
3	1800	182HP	1PC2822-1DB11-3TA3	575	1,635	4	89.5	129	1126	1134	39
3	1200	213HP	1PC2822-2AC31-3TA3	575	2,536	4.3	89.5	192	2442	2413	51
5	3600	184HP	1PC2822-1DA21-3TA3	575	2,596	6	88.5	130	889	896	34
5	1800	184HP	1PC2822-1DB21-3TA3	575	2,276	6.5	89.5	135	1116	1122	45
5	1200	215HP	1PC2822-2AC41-3TA3	575	3,571	6.7	89.5	204	2426	2413	62
7.5	3600	213HP	1PC2822-2AA31-3TA3	575	3,130	8.8	89.5	188	1681	1699	40
7.5	1800	213HP	1PC2822-2AB31-3TA3	575	3,119	9.7	91.7	211	2102	2123	66
7.5	1200	254HP	1PC2822-2BC31-3TA3	575	4,258	10	91	294	2389	2413	86
10	3600	215HP	1PC2822-2AA41-3TA3	575	3,506	11.5	90.2	202	1668	1688	52
10	1800	215HP	1PC2822-2AB41-3TA3	575	3,509	12.5	91.7	220	2091	2111	75
10	1200	256HP	1PC2822-2BC41-3TA3	575	4,810	13.5	91	310	2369	2399	100
15	3600	254HP	1PC2822-2BA31-3TA3	575	4,042	17.5	91	309	1631	1664	76
15	1800	254HP	1PC2822-2BB31-3TA3	575	4,192	19	92.4	315	2052	2082	97
15	1200	284HP	1PC2822-2CC31-3TA3	575	5,608	21	91.7	494	2212	2258	97
20	3600	256HP	1PC2822-2BA41-3TA3	575	4,420	22.5	91	337	1609	1643	94
20	1800	256HP	1PC2822-2BB41-3TA3	575	4,779	25	93	342	2021	2052	122
20	1200	286HP	1PC2822-2CC41-3TA3	575	6,815	27	91.7	551	2175	2226	120
25	3600	284HP	1PC2822-2CA31-3TA3	575	4,425	29	91.7	454	1525	1567	66
25	1800	284HP	1PC2822-2CB31-3TA3	575	4,957	30	93.6	535	1890	1940	109
25	1200	324HP	1PC2822-3AC31-3TA3	575	7,420	33	93	773	2807	2906	169
30	3600	286HP	1PC2822-2CA41-3TA3	575	4,790	34	91.7	486	1508	1552	78
30	1800	286HP	1PC2822-2CB41-3TA3	575	5,576	35	93.6	544	1876	1923	117
30	1200	326HP	1PC2822-3AC41-3TA3	575	8,472	39	93	809	2779	2879	187
40	3600	324HP	1PC2822-3AA31-3TA3	575	6,576	45	93.6	674	1952	2025	106
40	1800	324HP	1PC2822-3AB31-3TA3	575	6,642	46	94.1	737	2427	2514	153
40	1200	364HP	1PC2822-3CC31-3TA3	575	11,091	49	94.1	802	3267	3388	187
50	3600	326HP	1PC2822-3AA41-3TA3	575	8,249	55	93.6	689	1938	2007	114
50	1800	326HP	1PC2822-3AB41-3TA3	575	7,876	58	94.5	846	2366	2468	196
50	1200	365HP	1PC2822-3CC41-3TA3	575	13,076	62	94.1	835	3229	3348	208
60	3600	364HP	1PC2822-3CA31-3TA3	575	10,498	68	93.6	817	2226	2345	153
60	1800	364HP	1PC2822-3CB31-3TA3	575	10,442	68	95	865	2767	2908	215
60	1200	404HP	1PC2822-4AC31-3TA3	575	14,911	74	94.5	1000	3125	3283	274
75	3600	365HP	1PC2822-3CA41-3TA3	575	12,977	86	94.1	857	2192	2314	175
75	1800	365HP	1PC2822-3CB41-3TA3	575	13,020	85	95.4	928	2703	2856	255
75	1200	405HP	1PC2822-4AC41-3TA3	575	17,483	93	94.5	1068	3064	3227	310
100	3600	405HP	1PC2822-4AA41-3TA3	575	17,288	108	94.1	1023	2110	2255	230
100	1800	405HP	1PC2822-4AB41-3TA3	575	16,068	113	95.4	1073	2616	2786	304
100	1200	444HP	1PC2822-4HC11-3TA3	575	23,373	117	95	1372	3479	3743	347
125	1800	444HP	1PC2822-4HB11-3TA3	575	21,035	143	95.4	1419	2985	3243	342
125	1200	445HP	1PC2822-4HC21-3TA3	575	28,254	144	95	1557	3310	3633	448
150	1800	445HP	1PC2822-4HB21-3TA3	575	24,266	170	95.8	1559	2874	3166	411
150	1200	447HP	1PC2822-4HC31-3TA3	575	35,111	172	95.8	1786	3160	3539	522
200	1800	447HP	1PC2822-4HB31-3TA3	575	33,168	226	96.2	1854	2678	3035	516
200	1200	449HP	1PC2822-4HC51-3TA3	575	40,004	227	95.8	2216	2880	3365	665
250	1800	449HP	1PC2822-4HB51-3TA3	575	38,535	278	96.2	2246	2466	2903	631
250	1200	449HP	1PC2822-4HC61-3TA3	575	43,994	281	95.8	2203	2853	3284	671

NEMA Premium is a certification mark of the National Electrical Manufacturer's Association.
QuikMOD Delivery is for stocked motors only.



SIMOTICS Definite Purpose Motors

SD10 MS

SD10 MS (Cast Iron Frame) Rotor: Die Cast Aluminum Eff: NEMA Premium						Delivery Category:	Stock	Quick Mod	Custom Build
Power HP	Speed Rpm	NEMA Frame	Base Part Number	Voltage	Foot Mounted	FLC Amps	Eff	Weight Lbs	
					List price \$				
1/0.25	1800/900	143T	1LE2301-1AM24-0AA3	460	772	1.6/1.8	81.0/64.5	78	
1.5/0.37	1800/900	145T	1LE2301-1AM34-0AA3	460	856	2.3/1.1	81.3/65.5	82	
2/0.5	1800/900	182T	1LE2301-1CM14-0AA3	460	948	3.4/1.5	86.5/74.0	108	
3/0.75	1800/900	184T	1LE2301-1CM34-0AA3	460	1,052	4.4/1.9	87.5/78.5	114	
5/1.2	1800/900	213T	1LE2301-2AM14-0AA3	460	1,229	7.7/3.0	86.5/75.5	125	
7.5/1.9	1800/900	215T	1LE2301-2AM24-0AA3	460	1,617	9.6/3.7	87.5/78.5	195	
10/2.5	1800/900	254T	1LE2301-2BM14-0AA3	460	2,006	12.5/4.8	90.4/85.8	200	
15/3.7	1800/900	256T	1LE2301-2BM24-0AA3	460	2,642	18.0/7.0	90.2/86.5	256	
20/5	1800/900	284T	1LE2301-2CM14-0AA3	460	3,293	25/9.3	88.5/84	370	
20/5	1800/900	284T	1LE2301-2CM14-0AA3	460	3,293	25/9.3	88.5/84	370	
25/6.2	1800/900	286T	1LE2301-2CM24-0AA3	460	3,905	30/11.5	89.5/85.5	430	
30/7.5	1800/900	324T	1LE2301-3AM14-0AA3	460	4,552	35/13	91.7/88.5	565	
40/10	1800/900	326T	1LE2301-3AM24-0AA3	460	6,047	46/17	92.4/88.5	600	
50/12	1800/900	364T	1LE2301-3CM14-0AA3	460	7,427	58/22.5	93/89.5	831	
60/15	1800/900	365T	1LE2301-3CM24-0AA3	460	10,655	93.3/86.2	93/88.5	875	
75/19	1800/900	405T	1LE2301-4AM24-0AA3	460	13,506	86/32	93/88.5	1050	
100/25	1800/900	R444T	1LE2301-4CM14-0AA3	460	15,871	118/46	93.6/91	1625	
100/25	1800/900	444T	1LE2301-4EM14-0AA3	460	15,263	118/46	93.6/91	1625	
100/25	1800/900	444TS	1LE2301-4DM14-0AA3	460	15,263	118/46	93.6/91	1625	
125/31	1800/900	R445T	1LE2301-4CM24-0AA3	460	20,047	158/57	93/91.7	1900	
125/31	1800/900	445T	1LE2301-4EM24-0AA3	460	19,439	158/57	93/91.7	1900	
125/31	1800/900	445TS	1LE2301-4DM24-0AA3	460	19,439	158/57	93/91.7	1900	
150/37	1800/900	R447T	1LE2301-4CM34-0AA3	460	24,071	176/68	93.6/90.2	2280	
150/37	1800/900	447T	1LE2301-4EM34-0AA3	460	23,463	176/68	93.6/90.2	2280	
150/37	1800/900	447TS	1LE2301-4DM34-0AA3	460	23,463	176/68	93.6/90.2	2280	
200/50	1800/900	R449T	1LE2301-4CM54-0AA3	460	28,821	230/86	94.5/93	2600	
200/50	1800/900	449T	1LE2301-4EM54-0AA3	460	28,213	230/86	94.5/93	2600	
200/50	1800/900	449TS	1LE2301-4DM54-0AA3	460	28,213	230/86	94.5/93	2600	
250/62.5	1800/900	R449T	1LE2301-4CM64-0AA3	460	39,564	289/105	93.6/91	2600	
250/62.5	1800/900	449T	1LE2301-4EM64-0AA3	460	38,956	289/105	93.6/91	2600	

1) CW Rotation facing opposite DE; 2) NEMA design A

Note - 'R' before the frame designates the motor has Roller bearings

NEMA Premium is a certification mark of the National Electrical Manufacturer's Association.

QuikMOD Delivery is for stocked motors only.



SIMOTICS Definite Purpose Motors

SD10 MS (Continued)

SD10 MS (Cast Iron Frame) Rotor: Die Cast Aluminum Eff: NEMA Premium						Delivery Category:		Stock
								Quick Mod
								Custom Build
Power HP	Speed Rpm	NEMA Frame	Base Part Number	Voltage	Foot Mounted	FLC Amps	Eff	Weight Lbs
					List price \$			
25/6.2	1800/900	286T	1LE2301-2CM24-4AA3	575	3,905	30/11.5	89.5/85.5	430
30/7.5	1800/900	324T	1LE2301-3AM14-4AA3	575	4,552	35/13	91.7/88.5	565
40/10	1800/900	326T	1LE2301-3AM24-4AA3	575	6,047	46/17	92.4/88.5	600
50/12	1800/900	364T	1LE2301-3CM14-4AA3	575	7,427	58/22.5	93/89.5	831
60/15	1800/900	365T	1LE2301-3CM24-4AA3	575	10,655	93.3/86.2	93/88.5	875
75/19	1800/900	405T	1LE2301-4AM24-4AA3	575	13,506	86/32	93/88.5	1050
100/25	1800/900	R444T	1LE2301-4CM14-4AA3	575	15,871	118/46	93.6/91	1625
100/25	1800/900	444T	1LE2301-4EM14-4AA3	575	15,263	118/46	93.6/91	1625
100/25	1800/900	444TS	1LE2301-4DM14-4AA3	575	15,263	118/46	93.6/91	1625
125/31	1800/900	R445T	1LE2301-4CM24-4AA3	575	20,047	158/57	93/91.7	1900
125/31	1800/900	445T	1LE2301-4EM24-4AA3	575	19,439	158/57	93/91.7	1900
125/31	1800/900	445TS	1LE2301-4DM24-4AA3	575	19,439	158/57	93/91.7	1900
150/37	1800/900	R447T	1LE2301-4CM34-4AA3	575	24,071	176/68	93.6/90.2	2280
150/37	1800/900	447T	1LE2301-4EM34-4AA3	575	23,463	176/68	93.6/90.2	2280
150/37	1800/900	447TS	1LE2301-4DM34-4AA3	575	23,463	176/68	93.6/90.2	2280
200/50	1800/900	R449T	1LE2301-4CM54-4AA3	575	28,821	230/86	94.5/93	2600
200/50	1800/900	449T	1LE2301-4EM54-4AA3	575	28,213	230/86	94.5/93	2600
200/50	1800/900	449TS	1LE2301-4DM54-4AA3	575	28,213	230/86	94.5/93	2600
250/62.5	1800/900	R449T	1LE2301-4CM64-4AA3	575	39,564	289/105	93.6/91	2600
250/62.5	1800/900	449T	1LE2301-4EM64-4AA3	575	38,956	289/105	93.6/91	2600
250/62.5	1800/900	449TS	1LE2301-4DM64-4AA3	575	38,956	289/105	93.6/91	2600

1) CW Rotation facing opposite DE; 2) NEMA design A

Note - 'R' before the frame designates the motor has Roller bearings

NEMA Premium is a certification mark of the National Electrical Manufacturer's Association.

QuikMOD Delivery is for stocked motors only.



SIMOTICS Definite Purpose Motors

DP200

DP200 - HPS (Cast Iron Frame) Rotor: Die Cast Aluminum Eff: NEMA Premium							Delivery Category:		Stock	Quick Mod	Custom Build
Power HP	Speed Rpm	NEMA Frame	Base Part Number ■ ■ ■ = digits 14,15,16	Voltage	Digits 14,15,16			Eff	Weight Lbs		
					Foot Mounted No Protection	Foot Mounted w/ Stator RTD's*	FLC Amps				
					AA1	AK1					
List Price \$											
400	3600	509S	1PC6521-5EA11-2 ■ ■ ■	460	57,460	64,020	435	96.2%	4,219		
450	3600	5010S	1PC6521-5EA21-2 ■ ■ ■	460	58,590	65,150	490	96.2%	4,357		
500	3600	5011S	1PC6521-5EA81-2 ■ ■ ■	460	57,670	64,230	535	96.2%	4,504		
600	3600	5011S	1PC6521-5EA01-2 ■ ■ ■	460	65,140	71,700	650	96.5%	4,936		
700	3600	5013S	1PC6521-5FA71-2 ■ ■ ■	460	75,690	82,250	760	96.7%	5,538		
800	3600	5013S	1PC6521-5FA81-2 ■ ■ ■	460	79,380	85,940	850	96.7%	5,798		

*Stator RTD's 100 ohm platinum w aux box-terminal strip 2/phase
NEMA Premium is a certification mark of the National Electrical Manufacturer's Association.
QuikMOD Delivery is for stocked motors only.



Options Selection and Pricing

Introduction

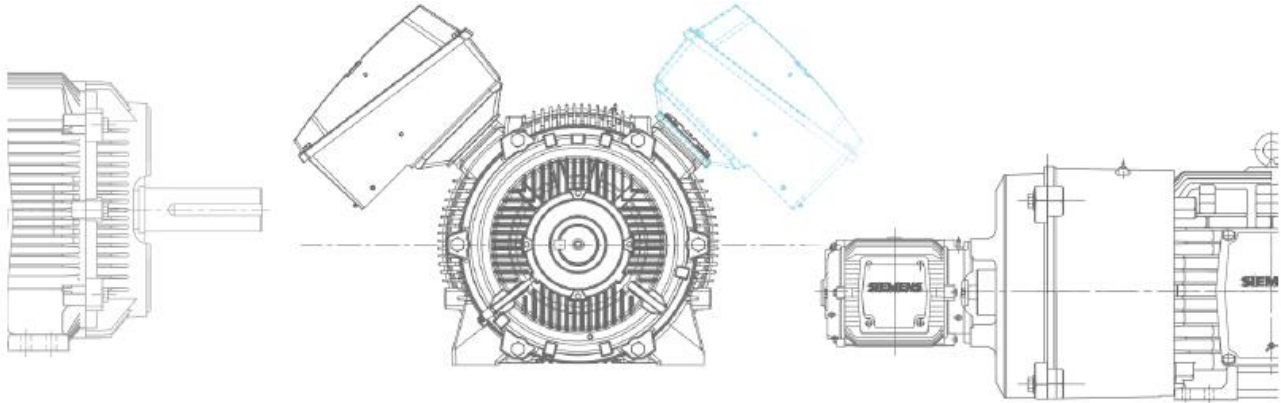

Siemens offers a wide selection of options to increase the suitability of our motors to the specific customer needs.

Modified Stock Options:

QM = QuikMOD

MOD = Modification

Custom Build Options:

Case A-1: Base Custom Delivery

Case A-2: One additional week

Case B: Three additional weeks

Definitions:

MLFB Digit – Modifications or Custom features that are built into the motor part number (MLFB).

Short Codes – Modifications or Custom features that are added after the part number.

Ordering Instructions:

1. Select a stock motor from the **Motor Selection and Pricing Section**. (Note Part Number)
2. **Verify applicability of desired Option(s) at the end of the section.** (Per motor type and frame)
3. **Select applicable Option(s).**
4. **Construct new Part Number and List Price.** (See example below)
 - a. If the MLFB Position is 12, 13, 14, 15 or 16, replace the number(s) or letter(s) at the same position(s) in the stock motor **Part Number** with the **MLFB Code**.
 - b. If the option is a **Short Code**, then add a '-Z' to the end of the motor **Part Number** and add the **short code**. Then add a '+' sign followed by the **additional short Code(s)**.

Custom Options combined with QuikMOD Motor Pricing Example:

Example: 15HP, 1800RPM, 208-230/460V, 254T, SD100, Copper Rotor, D-flange with feet, PTC thermistors (3 embedded temperature sensors for tripping) with condulet to main box and Class H insulation.

Base List Price:	\$2,131	Part Number 1LE23112BB114AA3
List Price Adders:		
D-Flange with Feet	\$774	Order Code F , Order Code Position 14
PTC Thermistors	\$634	Order Code B , Order Code Position 15
Condulet to Main Box	\$251	Order Code J02 , Order Code Position Z
Class H Insulation	<u>\$157</u>	Order Code C00 , Order Code Position Z
Total List Price:	\$3,947	New Part Number – 1LE23112BB114FB3-Z J02+C00
Delivery:		Please contact Siemens for delivery



Options Selection and Pricing

Modified Stock Options

	1LE2	1MB2	1PC2	1LE6	1PC6 HPS	Codes	Description	Case	140	180	210	250	280	320	360	400	440	S449	500	Notes	
Voltage and Connection																					
MLFB DIGITS 12 & 13	✓	✓	✓	--	--	11	230V	QM	123	123	138	159	161	161	191	191	230	--	--	Must be stocked with Voltage code "14" OR "16"	
	✓	✓	✓	✓	✓	12	460V	QM	123	123	138	159	161	161	191	191	230	0	0	Must be stocked with Voltage code "14" OR "16"	
	✓	✓	✓	--	--	16	230/460	QM	0	0	0	0	0	0	0	0	0	--	--	Must be stocked with Voltage code "14"	
	--	--	--	✓	✓	22	PWS 460V 60Hz	QM	--	--	--	--	Cust.	Cust.	Cust.	Cust.	Cust.	Cust.	Cust.	1520	
	--	--	--	✓	✓	32	Y/D 460V 60Hz	QM	--	--	--	--	Cust.	Cust.	Cust.	Cust.	Cust.	Cust.	Cust.	1520	
Mounting																					
MLFB DIGIT 14	✓	✓	--	--	--	E	C - Face with Feet	QM	106	154	164	229	870	941	1016	1261	1493	Cust.	--	Ball Bearing Only	
	✓	✓	--	--	--	F	D - Flange with Feet	QM	284	361	396	774	1086	1269	1481	1976	2387	Cust.	--	NO XP 140-250; Ball Bearing Only	
	✓	✓	--	--	--	G	C - Face without Feet	MOD	90	132	132	180	Cust.	Cust.	Cust.	Cust.	Cust.	--	--	Ball Bearing Only; Only is stocked as Round Frame	
	✓	✓	--	--	--	H	D - Flange without Feet	MOD	302	396	428	809	Cust.	Cust.	Cust.	Cust.	Cust.	--	--	NO XP 140-250; Ball Bearing Only; Only is stocked as Round Frame	
	✓	✓	--	--	--	L	C - Face without Feet with Drip Cover and Lifting Hooks	QM	214	237	239	318	Cust.	Cust.	Cust.	Cust.	Cust.	--	--	Ball Bearing Only; Only is stocked as Round Frame	
	✓	✓	--	--	--	M	D - Flange without Feet with Drip Cover and Lifting Hooks	MOD	455	549	581	976	Cust.	Cust.	Cust.	Cust.	Cust.	--	--	NO XP 140-250; Ball Bearing Only; Only is stocked as Round Frame	
	✓	✓	--	--	--	N	C - Face w Feet with Drip Cover	QM	359	402	436	792	1037	1236	1615	2099	3043	Cust.	--	Ball Bearing Only	
	✓	✓	--	--	--	P	D - Flange w Feet with Drip Cover	QM	437	514	549	941	Cust.	Cust.	Cust.	Cust.	Cust.	Cust.	--	--	NO XP 140-250; Ball Bearing Only
	--	--	--	✓	✓	C	Foot Mounted Vertical Shaft-Down without Canopy (IMV5)	MOD	--	--	--	--	--	--	--	--	--	--	--	7440	
	--	--	--	✓	✓	D	Foot Mounted Vertical Shaft-up (IMV6)	MOD	--	--	--	--	--	--	--	--	--	--	--	7440	

Note: Delivery time subject to change based on stock at time of order.

QM = Quick Modification – 2-3 days modification

MOD = Engineered Modification – 10 days modification

Legend

✓ Available

■ Standard

C Custom - See Custom Options

-- Not Available



Options Selection and Pricing

Modified Stock Options (continued)

	1LE2	1MB2	1PC2	1LE6	1PC6 HPS	Codes	Description	Case	140	180	210	250	280	320	360	400	440	S449	500	Notes	
Winding Protection																					
MLFB DIGIT 15	✓	✓	✓	✓	✓	G	Thermostats normally closed, Temp code T3C, 1 per phase	QM	229	229	229	229	229	306	306	459	566	661	670	NO GPA, XP100 1D1	
	--	--	--	✓	✓	H	Thermostats Normally Closed, Temp Code T3 - 200°C, 1 Per Phase	QM	--	--	--	--	--	--	--	--	--	--	670		
	C	C	C	✓	✓	L	Winding Protection - G + K	QM	--	--	--	--	--	--	Cust.	Cust.	Cust.	Cust.	6700	Only is stocked with "K"	
	C	C	C	✓	✓	M	Winding Protection - H + K	QM	--	--	--	--	--	--	Cust.	Cust.	Cust.	Cust.	6700	Only is stocked with "K"	
Short Codes	✓	--	✓	--	--	A40	Space Heaters 115V Single Phase	QM	352	352	352	352	528	528	528	612	612	699	--	NO GPA	
	✓	--	✓	--	--	A41	Space Heaters 230V Single Phase	QM	352	352	352	352	528	528	528	612	612	699	--	NO GPA	
	✓	--	✓	--	--	A42	Space Heaters 115V Single Phase, Division 2	QM	455	455	455	455	679	679	816	997	1181	1259	--	NO GPA	
	✓	--	✓	--	--	A44	Space Heaters 230V Single Phase, Division 2	QM	455	455	455	455	679	679	816	997	1181	1259	--	NO GPA	
	✓	✓	✓	✓	✓	A46	Space Heaters 115V Single Phase, Max Temp 160°C	QM	610	610	610	610	610	610	610	610	610	610	610	610	NO GPA
	✓	✓	✓	✓	✓	A47	Space Heaters 230V Single Phase, Max Temp 160°C	QM	610	610	610	610	610	610	610	610	610	610	610	610	NO GPA
	✓	--	✓	✓	✓	C07	Insulation Fungus Protection - No UL	QM	212	212	212	310	310	310	537	537	537	537	150	NO GPA	
Terminal boxes and Leads																					
MLFB DIGIT 16	✓	--	--	--	--	0	F-3 Top Mounted Box	QM	125	125	125	125	--	--	--	--	--	--	--	ONLY GP100A	
	✓	✓	--	--	--	1	C-2 Ceiling	QM	134	134	134	134	134	134	134	134	134	134	134	--	
	✓	C	--	--	--	2	F-2	QM	284	284	284	284	284	284	284	284	284	284	284	--	
	✓	✓	--	--	--	4	W-6 Shaft Down	QM	202	202	202	202	202	202	202	202	202	202	202	--	
	✓	C	--	--	--	5	W-7 (F-2) Shaft Down	QM	288	288	288	288	288	288	288	288	288	288	288	--	
	✓	C	--	--	--	6	W-5 (F-2) Shaft Up	QM	284	284	284	284	284	284	284	284	284	284	284	--	
	✓	✓	--	--	--	7	W-8 Shaft Up	QM	131	131	131	131	131	131	131	131	131	131	131	--	
	✓	C	--	--	--	8	C-1 (F-2) Ceiling	QM	284	284	284	284	284	284	284	284	284	284	284	--	
	✓	C	--	--	--	9-R1A	W-1 (F-2) Wall	QM	284	284	284	284	284	284	284	284	284	284	284	--	
	✓	✓	--	--	--	9-R2A	W-2 Wall	QM	130	130	130	130	130	130	130	130	130	130	130	--	
	✓	✓	--	--	--	9-R3A	W-3 Wall	QM	130	130	130	130	130	130	130	130	130	130	130	--	
	✓	C	--	--	--	9-R4A	W-4 (F-2) Wall	QM	284	284	284	284	284	284	284	284	284	284	284	--	
	--	--	--	✓	✓	2	RHS Mount - View From DE - Drive End Side	QM	--	--	--	--	--	--	--	--	--	--	--	300	
	--	--	--	✓	✓	3	Top Mounted Terminal Box from LHS - Drive End Side	QM	--	--	--	--	--	--	--	--	--	--	--	300	

Legend

✓	Available
■	Standard
C	Custom - See Custom Options
--	Not Available

Note: Delivery time subject to change based on stock at time of order.

QM = Quick Modification – 2-3 days modification

MOD = Engineered Modification – 10 days modification



Options Selection and Pricing

Modified Stock Options (continued)

	1LEZ	1MB2	1PC2	1LE6	1PC6 HPS	Codes	Description	Case	140	180	210	250	280	320	360	400	440	S449	500	Notes		
Terminal boxes and Leads																						
Short Codes	✓	--	✓	✓	✓	J10	Separate Condulet on Main Box Side for Thermostats	MOD	--	--	--	--	235	235	235	235	235	235	235	560	NO GP100A	
	--	--	--	✓	✓	J11	Aux Box on Same Side as Main for Thermostats	MOD	--	--	--	--	--	--	--	--	--	--	--	--	1160	
	✓	--	✓	✓	✓	J12	Condulet to Main Box for Thermostats	QM	251	251	251	251	251	251	251	251	251	251	251	251	560	NO GP100A, GP100
	✓	--	✓	✓	✓	J13	Aux Box to Main Box for Thermostats	MOD	--	--	--	--	415	415	415	415	415	415	415	415	970	NO GP100A, GP100
	✓	--	✓	✓	✓	J14	Condulet Opp Side to Main for Thermostats	MOD	--	--	--	--	235	235	235	235	235	235	235	235	560	NO GP100A
	✓	--	✓	✓	✓	J15	Aux Box Opp Side to Main for Thermostats	MOD	--	--	--	--	443	443	443	443	443	443	443	443	1160	NO GP100A
	✓	--	✓	✓	✓	J50	Separate Condulet on Main Box Side for Space Heaters	MOD	--	--	--	--	235	235	235	235	235	235	235	235	560	NO GP100A
	--	--	--	✓	✓	J51	Aux Box on Same Side as Main for Space Heaters	QM	--	--	--	--	--	--	--	--	--	--	--	--	1160	
	✓	--	✓	✓	✓	J52	Condulet to Main Box for Space Heaters	QM	251	251	251	251	251	251	251	251	251	251	251	251	560	NO GP100A, GP100
	✓	--	✓	✓	✓	J53	Aux Box to Main Box for Space Heaters	MOD	--	--	--	--	415	415	415	415	415	415	415	415	970	NO GP100A, GP100
	✓	--	✓	✓	✓	J54	Condulet Opp Side to Main for Space Heaters	MOD	--	--	--	--	235	235	235	235	235	235	235	235	560	NO GP100A
	✓	--	✓	✓	✓	J55	Aux Box Opp Side to Main for Space Heaters	MOD	--	--	--	--	443	443	443	443	443	443	443	443	560	NO GP100A
	✓	✓	✓	✓	✓	J84	Conduit Box Orientation 90° CCW (Entry from DE)	QM	134	134	134	134	134	134	134	134	134	134	134	134	270	NO GP100A
	✓	✓	✓	✓	✓	J85	Conduit Box Orientation 180° CCW (Entry from Top)	QM	134	134	134	134	134	134	134	134	134	134	134	134	270	NO GP100A
	✓	✓	✓	✓	✓	J86	Conduit Box Orientation 270° CCW (Entry from ODE)	QM	134	134	134	134	134	134	134	134	134	134	134	134	270	NO GP100A
	✓	✓	✓	✓	✓	K80	BURNDY HYDENT YA Type Terminals	QM	171	171	171	171	171	171	171	171	171	171	171	171	150	
	✓	--	✓	--	--	K83	Terminal Block – 3 Lead Only	MOD	228	228	228	342	342	518	518	--	--	--	--	--	--	NO GP100A
✓	■	✓	--	--	K89	Sealed Leads	QM	150	150	150	150	150	150	150	200	200	200	200	200	--	NO GP100A	
✓	■	■	■	■	L01	Cast Iron in Lieu of Aluminum	QM 140-250 MOD 280-400	148	154	161	167	180	199	218	251	--	--	--	--	--	ONLY GP100	
--	--	--	✓	✓	T00	Main Terminal Box - at a 45° Angle	QM	--	--	--	--	--	--	--	--	--	--	--	--	270		
--	--	--	✓	✓	T25	Main Terminal Box - at Non Drive End Side	QM	--	--	--	--	--	--	--	--	--	--	--	--	150		

Legend

✓	Available
■	Standard
C	Custom - See Custom Options
--	Not Available

Note: Delivery time subject to change based on stock at time of order.

QM = Quick Modification – 2-3 days modification

MOD = Engineered Modification – 10 days modification



Options Selection and Pricing

Modified Stock Options (continued)

	1LE2	1MB2	1PC2	1LE6	1PC6 HPS	Codes	Description	Case	140	180	210	250	280	320	360	400	440	S449	500	Notes		
Bearings and Lubrication																						
	--	--	--	--	✓	A50	Install Bearing RTD's-100 Ohm Platinum - Both Ends & Terminal Heads/Block	QM	--	--	--	--	--	--	--	--	--	--	--	3070		
	✓	✓	✓	✓	✓	L57	MOBIL 28- High or Low - Special Grease	MOD	485	895	895	895	895	1230	1230	1640	1640	1640	1640	1650	NO GP100A	
	✓	✓	✓	✓	✓	L58	MOBILITH SHC 100 - Special Grease	MOD	336	336	336	336	336	634	634	634	634	634	634	850	NO GP100A	
	✓	--	✓	■	■	L60	ALEMITE and Grease Relief Fitting	QM	186	186	186	186	186	186	186	186	186	186	186	186	■ GP100 280-S449 ONLY, STD on SD100 IEEE, SD661	
	✓	✓	✓	✓	■	L61	Insulated Bearing - INSOCOAT (Both Ends)	QM	--	--	--	--	--	3560	3700	4000	4000	4700	4700	5180	NO GP, MS, LP100, Roller Bearing on DE	
	✓	✓	✓	✓	✓	L64	Insulated Bearing - INSOCOAT (NDE Only)	QM	--	--	--	--	--	1650	1850	2000	2000	2350	2350	2590	NO GP, MS, LP100	
	✓	✓	✓	--	--	L68	Sealed Ball Bearings (Both Ends)	QM	229	229	229	458	458	458	572	916	916	1207	--	--	NO SD IEEE, SD661, NO 2 Pole for 360-S449	
	✓	✓	--	✓	✓	L69	Hybrid (Ceramic Ball) Bearings - Both Ends	QM	1328	1328	2096	2332	3316	4818	6236	10850	11606	12750	19730	19730	NO GP, MS, LP100, Roller Bearing on DE	
	✓	✓	✓	✓	✓	L70	Hybrid (Ceramic Ball) Bearings - NDE	QM	664	664	1048	1166	1658	2409	3118	5425	5803	6150	9870	9870	NO GP, MS, LP100	
	✓	✓	✓	✓	✓	L71	Hybrid (Ceramic Ball) Bearings - DE	QM	664	664	1048	1166	1658	2409	3118	5425	5803	6150	9870	9870	NO GP, MS, Roller Bearing on DE	
Shafts and Seals																						
Short Codes	✓	--	--	✓	✓	L29	Shaft Grounding Brush	MOD	--	--	--	--	3092	3092	3092	3092	3092	3092	3092	9860	NO GP100A, GP100	
	✓	✓	✓	--	--	L76	Shaft Slinger & O Ring	QM	88	88	88	121	121	164	164	213	213	213	213	--	NO GP100A, NO 2 Pole	
	✓	✓	✓	✓	✓	L79	INPRO/SEAL DE	QM	511	511	533	622	644	678	778	955	1044	1044	1150	1150	NO GP100A; Standard on SD100 IEEE, SD661	
	✓	✓	✓	✓	✓	L80	INPRO/SEAL ODE	QM	511	511	533	622	644	678	778	955	1044	1044	1150	1150	NO GP100A; Standard on SD100 IEEE, SD661	
	✓	✓	✓	✓	✓	L81	INPRO/SEAL Both Ends	QM	1021	1021	1066	1244	1289	1356	1556	1911	2088	2088	2300	2300	NO GP100A; Standard on SD100 IEEE, SD661	
	✓	✓	✓	--	--	L84	Brass Seal	MOD	133	133	133	133	133	133	133	133	133	133	--	--	--	NO S449, NO GP; Standard on SD100 IEEE, SD661
	✓	--	✓	✓	✓	L86	INPRO/SEAL MGS Shaft Grounding - DE	MOD	747	807	845	975	975	1134	1134	1356	1638	2070	4170	4170	NO GP, GPA, MS	
	✓	✓	✓	■	■	L87	ORION Labrinth Copper Seal - DE	QM	100	100	100	100	125	180	200	230	250	250	250	250	250	■ NO GP100A
	✓	✓	✓	✓	✓	L88	ORION Labrinth Copper Seal - ODE	QM	100	100	100	100	125	180	200	230	250	250	250	250	250	NO GP100A
	✓	✓	✓	--	--	L89	ORION Labrinth Copper Seal-Both Ends	QM	150	150	200	200	250	360	380	450	500	500	500	--	--	NO GP100A

Legend

✓	Available
■	Standard
C	Custom - See Custom Options
--	Not Available

Note: Delivery time subject to change based on stock at time of order.

QM = Quick Modification – 2-3 days modification

MOD = Engineered Modification – 10 days modification



Options Selection and Pricing

Modified Stock Options (continued)

	1LE2	1MB2	1PC2	1LE6	1PC6 HPS	Codes	Description	Case	140	180	210	250	280	320	360	400	440	S449	500	Notes		
Frame																						
Short Codes	✓	✓	■	--	--	K33	Drip Cover	QM	153	153	153	167	167	295	599	838	1550	1550	2970			
	✓	✓	■	--	--	K34	Lifting Hooks (No Drip Cover)	MOD	235	286	286	388	416	720	720	908	1001	1001	--	NO GP100A, SD661		
	✓	✓	--	■	■	K38	Provisions for Dowel Holes	MOD	--	--	--	--	435	483	530	614	915	915	■	NO GP100A		
	✓	✓	✓	✓	✓	K70	Rotation Arrow Bidirectional (Not for Uni-Directional)	QM	142	142	142	142	142	142	142	142	142	142	142	150		
	✓	✓	✓	✓	✓	K71	Rotation Arrow Clockwise (From NDE)	QM	142	142	142	142	142	142	142	142	142	142	142	150		
	✓	✓	✓	✓	✓	K72	Rotation Arrow Counterclockwise (From NDE)	QM	142	142	142	142	142	142	142	142	142	142	142	150	MOD if CW Motor selected	
	✓	■	■	■	■	L20	Lifting Eyebolt	QM	43	■	■	■	■	■	■	■	■	■	■	■	■	ONLY GP100
	✓	--	✓	--	--	L22	Stainless Steel Hardware (Includes T Drain SS)	QM	203	203	203	203	203	251	308	380	468	641	650		NO GP100A	
	✓	✓	✓	✓	✓	L27	Ground Bolts - Qty 2	QM	142	142	142	164	164	186	186	186	266	266	150		NO GP100A	
	✓	--	✓	✓	✓	L45	SST - Slot Breather Drain	QM	161	161	161	234	234	234	307	307	307	307	300		NO GP100A	
	✓	✓	✓	✓	✓	L46	CROUSE HINDS UL Approved Breather Drain	MOD	--	--	--	--	353	353	353	353	353	353	380		NO GP100A	
	--	✓	--	--	--	L90	IP66 Ingress Protection	QM	1021	1021	1066	1244	1289	1356	1556	1911	2088	--	--			
	✓	--	--	--	--	M09	Aluminum Fan	MOD	145	163	166	197	209	228	238	273	315	--	--		ONLY SD100	
	✓	--	✓	--	--	M10	Bronze Fan	MOD	546	546	706	752	941	1137	1190	1325	1830	--	--		NO GP100A	
✓	--	--	--	--	M28	Stainless Steel Eyebolt	QM	161	161	161	161	161	161	161	161	161	161	--		NO GP100A		
✓	✓	--	C	C	M39	Vertical Jacking Provisions	MOD	--	--	--	--	890	890	890	890	890	890	890	Cust.	NO GP100A		
Rating Plates and Tagging																						
Short Codes	✓	--	✓	✓	✓	M22	Class I, Division 2 Tag	QM	322	322	322	322	322	322	322	322	322	322	322	150	NO GP	
	✓	✓	✓	✓	✓	M23	Space Heaters Caution Plate	QM	43	43	43	43	43	43	43	43	43	43	43	150		
	✓	✓	✓	✓	✓	M24	Lubrication Plate	QM	104	104	104	104	104	104	104	104	104	104	130			
	✓	--	✓	--	--	M25	Class II, Division 2		1021	1021	1066	1244	1289	1356	1556	1911	2088	2088	--		NO GP	
	✓	✓	✓	✓	✓	Y80	Derate-Alt-Amb (Nameplate Change)	QM	164	164	164	164	164	164	164	164	164	164	164	170		
	✓	✓	✓	✓	✓	Y82	Auxiliary n/p Max. 40 Characters (Aux Tag)	QM	164	164	164	164	164	164	164	164	164	164	100			

Note: Delivery time subject to change based on stock at time of order.

QM = Quick Modification – 2-3 days modification

MOD = Engineered Modification – 10 days modification

Legend

✓ Available

■ Standard

C Custom - See Custom Options

-- Not Available



Options Selection and Pricing

Modified Stock Options (continued)

	1LE2	1MB2	1PC2	1LE6	1PC6 HPS	Codes	Description	Case	140	180	210	250	280	320	360	400	440	S449	500	Notes	
Mechanical Design and Accessories																					
Short Codes	✓	✓	--	--	--	M05	Larger Fan	MOD	--	--	--	--	--	--	320	320	360	--	--	NO GP, GPA, SD661; ONLY 4 Pole	
	✓	✓	✓	■	■	M69	Precision Balance	MOD	190	190	190	218	218	248	248	313	313	610	■	Standard on SD841, SD661	
	✓	✓	✓	■	■	M70	Extra Precision Balance	MOD	312	312	330	330	376	376	506	506	651	683	■		
Paint and Packaging																					
	✓	✓	✓	✓	✓	B09	Export Packaging Sea Freight – Siemens Standard	QM	98	125	125	125	230	290	360	740	1010	1010	2430		
Documentation																					
Short Codes	✓	✓	✓	✓	✓	F00	Certificate of Compliance	QM	300	300	300	300	300	300	300	300	300	300	300	300	
	✓	✓	✓	✓	✓	F03	Standard Performance Curves	QM	747	747	747	747	747	747	747	747	747	747	747	747	450
	✓	✓	✓	✓	✓	F07	Special Calculated Data	MOD	1195	1195	1195	1195	1195	1195	1195	1195	1195	1195	1195	1195	750
	✓	✓	✓	✓	✓	F40	Stall Time Curve (Thermal Limit Curve)	QM	45	45	45	45	45	45	45	45	45	45	45	45	150
	✓	✓	✓	✓	✓	F42	Standard Dimensional Sheet	QM	45	45	45	45	45	45	45	45	45	45	45	45	150
	✓	✓	✓	✓	✓	F43	Non-Standard Dimension Sheet	MOD	523	523	523	523	523	523	523	523	523	523	523	523	550
	✓	✓	✓	✓	✓	F44	Conduit Box Dimension Sheet	QM	45	45	45	45	45	45	45	45	45	45	45	45	150
	✓	✓	✓	✓	✓	F45	Wiring Diagram	QM	45	45	45	45	45	45	45	45	45	45	45	45	150
	✓	✓	✓	✓	✓	F46	Instruction & Operation Manual in English	QM	45	45	45	45	45	45	45	45	45	45	45	45	150
	✓	✓	✓	✓	✓	F47	Renewal Parts	MOD	45	45	45	45	45	45	45	45	45	45	45	45	150
	✓	✓	✓	✓	✓	F49	Performance Data Sheets	MOD	261	261	261	261	261	261	261	261	261	261	261	261	260
✓	✓	✓	✓	✓	F50	Customer Specific Data Sheets	MOD	523	523	523	523	523	523	523	523	523	523	523	523	550	
Tests																					
Short Codes	✓	✓	✓	✓	✓	F10	Routine Test Report	QM	300	300	300	300	300	300	300	300	300	300	300	300	NO SD IEEE, SD661
	✓	✓	✓	✓	✓	F12	Routine Test Report (Witnessed)	MOD	1628	1628	1628	1628	1643	1972	2360	2569	2778	3672	3700	NO SD IEEE, SD661	
	✓	✓	✓	C	C	F15	Complete Test	MOD	6749	6749	6749	6749	6812	7917	9680	11054	12010	13596	Cust.		
	✓	✓	✓	C	C	F17	Complete Test (Witnessed)	MOD	10123	10123	10123	10123	10217	11890	14519	16581	18015	20394	Cust.		
	✓	✓	✓	✓	✓	F20	Routine Test + Vibration	QM	600	600	600	600	600	600	600	600	600	600	600	600	
	✓	✓	✓	✓	✓	F22	Routine Test + Vibration (Witnessed)	MOD	3256	3256	3256	3256	3286	3286	3286	3286	3286	3286	3286	3286	3780
	✓	✓	✓	C	C	F27	Performance Load Test (Curve Report)	MOD	5062	5062	5062	5062	5109	5938	7260	8290	9007	10197	Cust.		
	✓	✓	✓	✓	✓	F36	Routine Test Report of Electrical Duplicate Design	MOD	300	300	300	300	300	300	300	300	300	300	300	300	
	✓	✓	✓	✓	✓	F37	Type Test Report of Electrical Duplicate Design	MOD	455	455	455	455	455	455	455	455	455	455	455	455	

Legend

✓	Available
■	Standard
C	Custom - See Custom Options
--	Not Available

Note: Delivery time subject to change based on stock at time of order.

QM = Quick Modification – 2-3 days modification

MOD = Engineered Modification – 10 days modification



Options Selection and Pricing

Custom Build Options

	1LE2	1MB2	1PC2	1LE6	1PC6 HPS	Codes	Description	Case	140	180	210	250	280	320	360	400	440	S449	500	Notes	
Voltage and Connection																					
MLFB DIGITS 12 & 13	✓	✓	✓	--	--	11	230V	A-1	123	123	138	159	161	161	191	191	230	--	--	1-75HP ONLY	
	✓	✓	✓	✓	✓	12	460V	A-1	123	123	138	159	161	161	191	191	230	0	0		
	✓	✓	✓	✓	✓	13	575V	A-1	0	0	0	0	0	0	0	0	0	0	0		
	✓	✓	✓	--	--	14	230/460 (suitable for 208V)	A-1	0	0	0	0	--	--	--	--	--	--	--	NO IEEE	
	✓	✓	✓	--	--	16	230/460	A-1	0	0	0	0	0	0	0	0	0	0	--	--	1-75HP ONLY, NO IEEE
	✓	✓	✓	✓	✓	22	PWS 460V 60Hz	A-1	--	--	--	--	165	200	294	461	767	767	1520		
	✓	✓	✓	✓	✓	23	PWS 575V 60Hz	A-1	--	--	--	--	165	200	294	461	767	767	1520		
	✓	✓	✓	✓	✓	32	Y/D 460V 60Hz	A-1	--	--	--	--	165	200	294	461	767	767	1520		
	✓	✓	✓	✓	✓	33	Y/D 575V 60Hz	A-1	--	--	--	--	165	200	294	461	767	767	1520		
✓	✓	✓	✓	✓	90	200-600V (M1Y 200-460, M2Y 461-600)	A-1	120	120	120	166	200	482	546	714	1187	1486	2930			
Mounting																					
MLFB DIGIT 14	✓	✓	--	--	--	A	Foot Mount	A-1	0	0	0	0	0	0	0	0	0	0	0	--	
	✓	✓	--	--	--	E	C - Face with Feet	A-1	106	154	164	229	870	941	1016	1261	1493	1720	--	NO 2 POLE 440 Frame IEEE, Roller Bearing	
	✓	✓	--	--	--	F	D - Flange with Feet	A-1	284	361	396	774	1086	1269	1481	1976	2387	2390	--	NO 2 POLE 440 Frame IEEE, XP 140-250, Roller Bearing	
	✓	✓	--	--	--	G	C - Face without Feet	A-1	90	132	132	180	939	1029	1308	1684	2303	--	--	NO 2 POLE 440 Frame IEEE, Roller Bearing	
	✓	✓	--	--	--	H	D - Flange without Feet	A-1	302	396	428	809	1224	1452	2005	2779	3896	--	--	NO 2 POLE 440 Frame IEEE, XP 140-250, Roller Bearing	
	✓	✓	--	--	--	L	C - Face without Feet with Drip Cover and Lifting Hooks	A-1	214	237	239	318	1106	1324	1907	2522	3853	--	--	NO 2 POLE 440 Frame IEEE, Roller Bearing	
	✓	✓	--	--	--	M	D - Flange without Feet with Drip Cover and Lifting Hooks	A-1	455	549	581	976	1391	1747	2604	3617	5446	--	--	NO 2 POLE 440 Frame IEEE, XP 140-250, Roller Bearing	
	✓	✓	--	--	--	N	C - Face w Feet with Drip Cover	A-1	359	402	436	792	1037	1236	1615	2099	3043	3270	--	NO 2 POLE 440 Frame IEEE, Roller Bearing	
	✓	✓	--	--	--	P	D - Flange w Feet with Drip Cover	A-1	437	514	549	941	1253	1564	2080	2814	3937	3940	--	NO 2 POLE 440 Frame IEEE, XP 140-250, Roller Bearing	
	--	--	✓	--	--	T	P-Base without Feet with Drip Cover and Lifting Hooks	A-1	■	■	■	■	■	■	■	■	■	--	--		
	--	✓	--	--	--	V	CH - Flange w Feet with Drip Cover and Lifting Hooks	A-1	--	342	--	--	--	--	--	--	--	--	--		
--	✓	--	--	--	W	CH - Flange with Feet	A-1	--	131	--	--	--	--	--	--	--	--	--			

Note: See Weekly Stock List for updated lead times on delivery cases
 Case A-1: Base Custom Delivery
 Case A-2: One additional week
 Case B: Three additional weeks

Legend

- ✓ Available
- Standard
- C Custom - See Custom Options
- Not Available



Options Selection and Pricing

Custom Build Options (continued)

	1LE2	1MB2	1PC2	1LE6	1PC6 HPS	Codes	Description	Case	140	180	210	250	280	320	360	400	440	S449	500	Notes	
Mounting																					
MLFB DIGIT 14	--	✓	--	--	--	X	CH - Flange without Feet	A-1	--	112	--	--	--	--	--	--	--	--	--	--	
	--	✓	--	--	--	Y	CH - Flange without Feet with Drip Cover and Lifting Hooks	A-1	--	202	--	--	--	--	--	--	--	--	--	--	
	--	--	--	✓	✓	A	Foot Mounted (Horizontal IMB3)	A-1	--	--	--	--	--	--	--	--	--	--	--	0	
	--	--	--	✓	✓	C	Foot Mounted Vertical Shaft-Down without Canopy (IMV5)	A-1	--	--	--	--	--	--	--	--	--	--	--	7440	
	--	--	--	✓	✓	D	Foot Mounted Vertical Shaft-Up (IMV6)	A-1	--	--	--	--	--	--	--	--	--	--	--	7440	
	--	--	--	✓	✓	J	Foot Mounted D-Flange Horizontal (IMB35 – F1/F2/F3)	A-1	--	--	--	--	--	--	--	--	--	--	--	2140	No Roller Bearing
	--	--	--	✓	✓	R	Foot Mounted D-Flange Vertical Shaft-Down – W6/W7/W12	A-1	--	--	--	--	--	--	--	--	--	--	--	9260	No Roller Bearing
	--	--	--	✓	✓	S	Foot Mounted D-Flange Vertical Shaft-Up – W5/W8/W11	A-1	--	--	--	--	--	--	--	--	--	--	--	9260	No Roller Bearing
Winding Protection																					
MLFB DIGIT 15	✓	✓	✓	✓	✓	A	No Protection	A-1	0	0	0	0	0	0	0	0	0	0	0	0	
	✓	✓	✓	✓	✓	B	PTC 3 Embedded, 1 Per Phase	A-1	634	634	634	634	634	634	634	634	634	634	634	640	NO GP100A
	✓	✓	✓	✓	✓	C	PTC 6 Embedded, 2 Per Phase	A-1	1268	1268	1268	1268	1268	1268	1268	1268	1268	1268	1280	NO GP100A	
	✓	✓	✓	✓	✓	G	Thermostats Normally Closed, Temp Code T3C, 1 Per Phase	A-1	229	229	229	229	229	306	306	459	566	661	670	NO GP100A, XP100 1D1	
	--	--	--	✓	✓	H	Thermostats Normally Closed, Temp Code T3 - 200°C, 1 Per Phase	A-1	--	--	--	--	--	--	--	--	--	--	--	670	
	✓	✓	✓	✓	✓	J	Thermocouples Coil Head	A-1	--	--	--	--	--	--	--	--	--	--	--	3710	NO GP100A
	✓	✓	✓	✓	✓	K	Stator RTD's 100-Ohm Platinum w Aux Box-terminal Strip 2/Phase	A-1	--	--	--	--	--	--	3053	3053	3053	3175	6560	NO GP100A, XP100 ID1	
	✓	✓	✓	✓	✓	L	Winding Protection - G + K	A-1	--	--	--	--	--	--	2795	2795	2795	2885	6700	NO GP100A, XP100 ID1	
	✓	✓	✓	✓	✓	M	Winding Protection - H + K	A-1	--	--	--	--	--	--	--	--	--	--	--	6700	NO GP100A, XP100 ID1
	✓	✓	✓	✓	✓	P	PT1000, 2 Embedded Temperature Sensors	A-1	1268	1268	1268	1268	1268	1268	1268	1268	1268	1268	1268	1120	NO GP100A

Note: See Weekly Stock List for updated lead times on delivery cases

Case A-1: Base Custom Delivery

Case A-2: One additional week

Case B: Three additional weeks

Legend

✓ Available

■ Standard

C Custom - See Custom Options

-- Not Available



Options Selection and Pricing

Custom Build Options (continued)

	1LE2	1MB2	1PC2	1LE6	1PC6 HPS	Codes	Description	Case	140	180	210	250	280	320	360	400	440	S449	500	Notes		
Winding Protection																						
Short Codes	✓	--	✓	--	--	A40	Space Heaters 115V Single Phase	A-1	352	352	352	352	528	528	528	612	612	699	--	NO GP100A		
	✓	--	✓	--	--	A41	Space Heaters 230V Single Phase	A-1	352	352	352	352	528	528	528	612	612	699	--	NO GP100A		
	✓	--	✓	--	--	A42	Space Heaters 115V Single Phase, Division 2	A-1	455	455	455	455	679	679	816	997	1181	1259	--	NO GP100A		
	--	✓	--	--	--	A43	Space Heaters 115V Single Phase, Explosion Proof	A-1	409	409	409	409	611	611	734	897	1062	NA	--			
	✓	--	✓	--	--	A44	Space Heaters 230V Single Phase, Division 2	A-1	455	455	455	455	679	679	816	997	1181	1259	--	NO GP100A		
	--	✓	--	--	--	A45	Space Heaters 230V Single Phase, Explosion Proof	A-1	409	409	409	409	611	611	734	897	1062	--	--			
	✓	✓	✓	✓	✓	A46	Space Heaters 115V Single Phase, Max Temp 160°C	A-1	610	610	610	610	610	610	610	610	610	610	610	610	NO GP100A	
	✓	✓	✓	✓	✓	A47	Space Heaters 230V Single Phase, Max Temp 160°C	A-1	610	610	610	610	610	610	610	610	610	610	610	610	NO GP100A	
	✓	✓	✓	--	--	A90	Control Module	B	725	725	725	725	725	725	725	725	725	725	725	725	--	NO GP100A
	✓	✓	✓	■	■	C00	Insulation Class H	A-1	122	122	122	157	261	343	438	634	904	2387	■	NO GP100A		
	✓	✓	✓	✓	✓	C01	Insulation Vacuum Pressure Impregnation (VPI)	A-2	1670	1670	1670	1670	2147	2147	2714	3430	3728	5463	34270	NO GP100A		
	✓	✓	✓	✓	✓	C03	Spike Resistant Wire	A-2	150	150	150	150	150	150	220	260	410	820	3480			
	✓	✓	✓	✓	✓	C04	Insulation Moisture/Powerhouse (Extra Dip & Bake)	A-2	160	160	160	208	345	447	567	798	1877	1877	1877	NO GP100A		
✓	--	✓	✓	✓	C07	Insulation Fungus Protection - No UL	A-1	212	212	212	310	310	310	537	537	537	537	150	NO GP100A			
✓	--	✓	✓	✓	C08	Insulation Tropicalization (Extra Dip & Bake + Fungus Spray)	A-2	214	214	214	277	459	593	746	1036	1406	2319	2027	NO GP100A			
Terminal boxes and Leads																						
MLB DIGIT 16	✓	--	--	--	--	0	F-3 Top Mounted Box	A-1	125	125	125	125	--	--	--	--	--	--	--	ONLY GP100A		
	✓	✓	--	--	--	1	C-2 Ceiling	A-1	134	134	134	134	134	134	134	134	134	134	--			
	✓	✓	--	--	--	2	F-2	A-1	284	284	284	284	284	284	284	284	284	284	--			
	✓	✓	✓	--	--	3	F-1	A-1	■	■	■	■	■	■	■	■	■	■	■	--		
	✓	✓	--	--	--	4	W-6 Shaft Down	A-1	202	202	202	202	202	202	202	202	202	202	202	--		
	✓	✓	--	--	--	5	W-7 (F-2) Shaft Down	A-1	288	288	288	288	288	288	288	288	288	288	288	--		
	✓	✓	--	--	--	6	W-5 (F-2) Shaft Up	A-1	284	284	284	284	284	284	284	284	284	284	284	--		
	✓	✓	--	--	--	7	W-8 Shaft Up	A-1	131	131	131	131	131	131	131	131	131	131	131	--		
	✓	✓	--	--	--	8	C-1 (F-2) Ceiling	A-1	284	284	284	284	284	284	284	284	284	284	284	--		

Note: See Weekly Stock List for updated lead times on delivery cases

Case A-1: Base Custom Delivery

Case A-2: One additional week

Case B: Three additional weeks

Legend

✓ Available

■ Standard

C Custom - See Custom Options

-- Not Available



Options Selection and Pricing

Custom Build Options (continued)

	1LE2	1MB2	1PC2	1LE6	1PC6 HPS	Codes	Description	Case	140	180	210	250	280	320	360	400	440	S449	500	Notes			
Terminal boxes and Leads																							
MLFB DIGIT 16	✓	✓	--	--	--	9-R1A	W-1 (F-2) Wall	A-1	284	284	284	284	284	284	284	284	284	284	284	--			
	✓	✓	--	--	--	9-R2A	W-2 Wall	A-1	130	130	130	130	130	130	130	130	130	130	130	130	--		
	✓	✓	--	--	--	9-R3A	W-3 Wall	A-1	130	130	130	130	130	130	130	130	130	130	130	130	--		
	✓	✓	--	--	--	9-R4A	W-4 (F-2) Wall	A-1	284	284	284	284	284	284	284	284	284	284	284	284	--		
	--	--	--	✓	✓	1	LHS Mount - View from DE -Drive End	A-1	--	--	--	--	--	--	--	--	--	--	--	--	0		
	--	--	--	✓	✓	2	RHS Mount - View from DE -Drive End Side	A-1	--	--	--	--	--	--	--	--	--	--	--	--	300		
	--	--	--	✓	✓	3	Top Mounted Terminal Box from LHS -Drive End Side	A-1	--	--	--	--	--	--	--	--	--	--	--	--	300		
	--	--	--	✓	✓	4	LHS Mount - View from DE -Non Drive End Side	A-1	--	--	--	--	--	--	--	--	--	--	--	--	300		
	--	--	--	✓	✓	5	RHS Mount - View from DE -Non Drive End Side	A-1	--	--	--	--	--	--	--	--	--	--	--	--	300		
	--	--	--	✓	✓	6	Top Mounted Terminal Box from RHS -Non Drive End Side	A-1	--	--	--	--	--	--	--	--	--	--	--	--	300		
Short Codes	✓	--	✓	✓	✓	J00	Separate Condulet on Main Box Side for PTC	A-1	--	--	--	--	235	235	235	235	235	235	235	560	NO GP100A		
	--	--	--	✓	✓	J01	Aux Box on Same Side as Main for PTC	A-1	--	--	--	--	--	--	--	--	--	--	--	--	1160		
	✓	--	✓	✓	✓	J02	Condulet to Main Box for PTC	A-1	251	251	251	251	251	251	251	251	251	251	251	251	560	NO GP	
	✓	--	✓	✓	✓	J03	Aux Box to Main Box for PTC	A-1	--	--	--	--	415	415	415	415	415	415	415	415	970	NO GP	
	✓	--	✓	✓	✓	J04	Condulet Opp Side to Main for PTC	A-1	--	--	--	--	235	235	235	235	235	235	235	235	560	NO GP100A	
	✓	--	✓	✓	✓	J05	Aux Box Opp Side to Main for PTC	A-1	--	--	--	--	443	443	443	443	443	443	443	443	1160	NO GP100A	
	--	✓	--	--	--	J06	Explosion Proof Condulet Opp to Main for PTC	A-1	560	560	560	560	560	560	560	560	560	560	560	560	--	--	
	--	✓	--	--	--	J07	Explosion Proof Condulet to Main Box for PTC	A-1	560	560	560	560	560	560	560	560	560	560	560	560	--	--	
	✓	--	✓	✓	✓	J10	Separate Condulet on Main Box Side for Thermostats	A-1	--	--	--	--	235	235	235	235	235	235	235	235	560	NO GP100A	
	--	--	--	✓	✓	J11	Aux Box on Same Side as Main for Thermostats	A-1	--	--	--	--	--	--	--	--	--	--	--	--	1160		

Note: See Weekly Stock List for updated lead times on delivery cases

Case A-1: Base Custom Delivery

Case A-2: One additional week

Case B: Three additional weeks

Legend

✓ Available

■ Standard

C Custom - See Custom Options

-- Not Available



Options Selection and Pricing

Custom Build Options (continued)

	1LE2	1MB2	1PC2	1LE6	1PC6 HPS	Codes	Description	Case	140	180	210	250	280	320	360	400	440	S449	500	Notes		
Terminal boxes and Leads																						
Short Codes	✓	--	✓	✓	✓	J12	Condulet to Main Box for Thermostats	A-1	251	251	251	251	251	251	251	251	251	251	251	560	NO GP	
	✓	--	✓	✓	✓	J13	Aux Box to Main Box for Thermostats	A-1	--	--	--	--	415	415	415	415	415	415	415	970	NO GP	
	✓	--	✓	✓	✓	J14	Condulet Opp Side to Main for Thermostats	A-1	--	--	--	--	235	235	235	235	235	235	235	560	NO GP100A	
	✓	--	✓	✓	✓	J15	Aux Box Opp Side to Main for Thermostats	A-1	--	--	--	--	443	443	443	443	443	443	443	1160	NO GP100A	
	--	✓	--	--	--	J16	Explosion Proof Condulet Opp to Main for Thermostats	A-1	560	560	560	560	560	560	560	560	560	560	NA	--		
	--	✓	--	--	--	J17	Explosion Proof Condulet to Main Box for Thermostats	A-1	560	560	560	560	560	560	560	560	560	560	--	--		
	✓	--	✓	✓	✓	J20	Separate Condulet on Main Box Side for PT1000	A-1	--	--	--	--	235	235	235	235	235	235	235	560	NO GP100A	
	--	--	--	✓	✓	J21	Aux Box on Same Side as Main for PT1000	A-1	--	--	--	--	--	--	--	--	--	--	--	--	1160	
	✓	--	✓	✓	✓	J22	Condulet to Main Box for PT1000	A-1	251	251	251	251	251	251	251	251	251	251	251	251	560	NO GP
	✓	--	✓	✓	✓	J23	Aux Box to Main Box for PT1000	A-1	--	--	--	--	415	415	415	415	415	415	415	415	970	NO GP
	✓	--	✓	✓	✓	J24	Condulet Opp Side to Main for PT1000	A-1	--	--	--	--	235	235	235	235	235	235	235	235	560	NO GP100A
	✓	--	✓	✓	✓	J25	Aux box Opp Side to Main for PT1000	A-1	--	--	--	--	443	443	443	443	443	443	443	443	1160	NO GP100A
	--	✓	--	--	--	J26	Explosion Proof Condulet Opp to Main for PT1000	A-1	560	560	560	560	560	560	560	560	560	560	560	--	--	
	--	✓	--	--	--	J27	Explosion Proof Condulet to Main Box for PT1000	A-1	560	560	560	560	560	560	560	560	560	560	560	--	--	
	✓	--	✓	✓	✓	J50	Separate Condulet on Main Box Side for Space Heaters	A-1	235	235	235	235	235	235	235	235	235	235	235	235	560	NO GP100A
	--	--	--	✓	✓	J51	Aux Box on Same Side as Main for Space Heaters	A-1	--	--	--	--	--	--	--	--	--	--	--	--	1160	
	✓	--	✓	✓	✓	J52	Condulet to Main Box for Space Heaters	A-1	251	251	251	251	251	251	251	251	251	251	251	251	560	NO GP
	✓	--	✓	✓	✓	J53	Aux Box to Main Box for Space Heaters	A-1	--	--	--	--	415	415	415	415	415	415	415	415	970	NO GP
✓	--	✓	✓	✓	J54	Condulet Opp Side to Main Box for Space Heaters	A-1	--	--	--	--	235	235	235	235	235	235	235	235	560	NO GP100A	
✓	--	✓	✓	✓	J55	Aux Box Opp Side to Main Box for Space Heaters	A-1	--	--	--	--	443	443	443	443	443	443	443	443	1160	NO GP100A	
--	✓	--	--	--	J56	Explosion Proof Condulet Opp of Main for Space Heaters	A-1	560	560	560	560	560	560	560	560	560	560	560	--	--		

Note: See Weekly Stock List for updated lead times on delivery cases

Case A-1: Base Custom Delivery

Case A-2: One additional week

Case B: Three additional weeks

Legend

✓ Available

■ Standard

C Custom - See Custom Options

-- Not Available



Options Selection and Pricing

Custom Build Options (continued)

	1LE2	1MB2	1PC2	1LE6	1PC6 HPS	Codes	Description	Case	140	180	210	250	280	320	360	400	440	S449	500	Notes		
Terminal boxes and Leads																						
Short Codes	--	✓	--	--	--	J57	Explosion Proof Condulet to Main Box for Space Heaters	A-1	560	560	560	560	560	560	560	560	560	--	--			
	✓	✓	✓	✓	✓	J84	Conduit Box Orientation 90° CCW (Entry from DE)	A-1	134	134	134	134	134	134	134	134	134	134	134	270	NO GP100A	
	✓	✓	✓	✓	✓	J85	Conduit Box Orientation 180° CCW (Entry from Top)	A-1	134	134	134	134	134	134	134	134	134	134	134	270	NO GP100A	
	✓	✓	✓	✓	✓	J86	Conduit Box Orientation 270° CCW (Entry from ODE)	A-1	134	134	134	134	134	134	134	134	134	134	134	270	NO GP100A	
	✓	✓	✓	✓	✓	K80	BURNDY HYDENT YA Type Terminals	A-2	171	171	171	171	171	171	171	171	171	171	171	150		
	--	--	--	✓	✓	K81	Special Cable Leads, 60" Long	A-1	--	--	--	--	--	--	--	--	--	--	--	--	3040	
	--	--	--	✓	✓	K82	Special Cable Leads, 120" Long	A-1	--	--	--	--	--	--	--	--	--	--	--	--	6620	
	✓	--	✓	--	--	K83	Terminal Block – 3 Lead Only	A-1	228	228	228	342	342	518	518	--	--	--	--	--	NO GP100A	
	✓	■	✓	--	--	K89	Sealed Leads	A-1	150	150	150	150	150	150	150	200	200	200	200	--	NO GP100A	
	✓	■	■	■	■	L01	Cast Iron Main Terminal Box in Lieu of Aluminum	A-2	148	154	161	167	180	199	218	251	--	--	--	--	ONLY GP100	
	--	--	--	✓	✓	T00	Main Terminal Box - at a 45° Angle	A-1	--	--	--	--	--	--	--	--	--	--	--	--	270	
	--	--	--	✓	✓	T25	Aux Terminal Box - at Non Drive End Side	A-1	--	--	--	--	--	--	--	--	--	--	--	--	150	
✓	--	✓	✓	✓	Y85	Special Cable Length	A-1	228	228	228	228	228	228	228	304	304	304	304	304	CF		
Bearings and Lubrication																						
Short Codes	--	--	--	--	--	A50	Install Bearing RTD's-100 Ohm Platinum-Both Ends & Terminal Heads/Block	A-1	--	--	--	--	--	--	--	--	--	--	--	3070		
	✓	--	✓	✓	✓	A51	Bearing RTD's-100 Ohm Platinum - Both Ends & Terminal Heads/Block	A-2	--	--	--	--	--	--	--	3347	3347	3347	3390	NO GP		
	--	✓	--	--	--	K21	Extra High Thrust	B	--	700	700	700	700	970	1230	1410	1760	--	--			
	✓	--	--	--	--	L54	Provisions for Oil Mist	A-1	--	--	--	--	380	380	650	1100	1350	--	--	NO GP		
	✓	--	--	--	--	L55	Oil Mist Ready	A-1	--	--	--	--	380	380	650	1100	1350	--	--	NO GP		
	✓	✓	✓	✓	✓	L57	MOBIL 28 - High or Low - Special Grease	A-2	485	895	895	895	895	1230	1230	1640	1640	1640	1650	NO GP100A		
	✓	✓	✓	✓	✓	L58	MOBILITH SHC 100 - Special Grease	A-2	336	336	336	336	336	634	634	634	634	634	850	NO GP100A		
	✓	--	✓	■	■	L60	ALEMITE and Grease Relief Fitting	A-1	186	186	186	186	186	186	186	186	186	186	186	STD	GP100 280-S449 ONLY, STD on SD100 IEEE, SD661	
	✓	✓	✓	✓	■	L61	Insulated Bearing - INSOCOAT (Both Ends)	A-1	--	--	--	--	--	3560	3700	4000	4000	4700	5180			
	✓	✓	✓	✓	✓	L64	Insulated Bearing - INSOCOAT (NDE Only)	A-1	--	--	--	--	--	1650	1850	2000	2000	2350	2590			
	✓	✓	--	--	--	L65	Roller Instead of Ball Bearings	A-2	--	--	--	--	1215	1215	1215	1215	--	--	--	NO GP		

Note: See Weekly Stock List for updated lead times on delivery cases
 Case A-1: Base Custom Delivery
 Case A-2: One additional week
 Case B: Three additional weeks

Legend

- ✓ Available
- Standard
- C Custom - See Custom Options
- Not Available



Options Selection and Pricing

Custom Build Options (continued)

	1LE2	1MB2	1PC2	1LE6	1PC6 HPS	Codes	Description	Case	140	180	210	250	280	320	360	400	440	S449	500	Notes	
Bearings and Lubrication																					
Short Codes	✓	--	--	✓	✓	L66	Insulated Bearings on Both Ends	B	765	765	1050	1315	2496	2961	3523	7645	11767	11843	12500	SD ONLY, NO Roller Bearing	
	✓	--	--	✓	✓	L67	Insulated NDE Only	B	380	385	525	660	1252	1484	1761	3823	5884	8343	6260	SD ONLY	
	✓	✓	✓	--	--	L68	Sealed Ball Bearings (Both Ends)	A-1	229	229	229	458	458	458	572	916	916	1207	--	NO SD IEEE, SD661, NO 2 pole for 360-5449	
	✓	✓	--	✓	✓	L69	Hybrid (Ceramic Ball) Bearings - both Ends	B	1328	1328	2096	2332	3316	4818	6236	10850	11606	12750	19730	NO GP, MS, LP100, Roller Bearing DE	
	✓	✓	✓	✓	✓	L70	Hybrid (Ceramic Ball) Bearings – NDE	B	664	664	1048	1166	1658	2409	3118	5425	5803	6150	9870	NO GP, MS, LP100	
	✓	✓	✓	✓	✓	L71	Hybrid (Ceramic Ball) Bearings – DE	B	--	664	1048	1166	1658	2409	3118	5425	5803	6150	9870	NO GP, MS, Roller Bearing DE	
Shafts and Seals																					
Short Codes	✓	✓	✓	✓	✓	K41	Keyless Shaft	A-1	250	250	250	250	250	250	250	250	250	250	250	420	NO GP
	✓	--	--	✓	✓	L29	Shaft Grounding Brush	A-2	--	--	--	--	3092	3092	3092	3092	3092	3092	3092	9860	NO GP
	✓	✓	✓	--	--	L76	Shaft Slinger & O Ring	A-1	88	88	88	121	121	164	164	213	213	213	--	NO GP100A, NO 2 Pole	
	✓	✓	✓	✓	✓	L79	INPRO/SEAL DE	A-1	511	511	533	622	644	678	778	955	1044	1044	1150	NO GP100A; STD ON SD IEEE, SD661	
	✓	✓	✓	✓	✓	L80	INPRO/SEAL ODE	A-2	511	511	533	622	644	678	778	955	1044	1044	1150	NO GP100A; STD ON SD IEEE, SD661	
	✓	✓	✓	✓	✓	L81	INPRO/SEAL Both Ends	A-2	1021	1021	1066	1244	1289	1356	1556	1911	2088	2088	2300	NO GP100A; STD ON SD IEEE, SD661	
	✓	✓	✓	--	--	L84	Brass Seal	A-1	133	133	133	133	133	133	133	133	133	--	--	NO S449, NO GP, SD IEEE, SD661	
	✓	--	✓	✓	✓	L86	INPRO/SEAL MGS Shaft Grounding – DE	A-1	747	807	845	975	975	1134	1134	1356	1638	2070	4170	NO GP, MS	
	✓	✓	✓	•	•	L87	ORION Labrinth Copper Seal – DE	A-1	100	100	100	100	125	180	200	230	250	250	250	250	NO GP100A
	✓	✓	✓	✓	✓	L88	ORION Labrinth Copper Seal – ODE	A-1	100	100	100	100	125	180	200	230	250	250	250	250	NO GP100A
	✓	✓	✓	--	--	L89	ORION Labrinth Copper Seal – Both Ends	A-1	150	150	200	200	250	360	380	450	500	500	--	--	NO GP100A
	✓	--	--	--	--	M42	Shaft Ring Brush (Steel) – NDE (AEGIS)	A-2	321	342	375	456	489	551	743	930	2270	--	--	GP100 ONLY	
	✓	✓	--	--	--	M52	NEMA Std Long Shaft – NDE	A-2	132	132	132	176	272	392	443	490	558	--	--	NO GP	
	✓	✓	--	--	--	M53	NEMA Std Short Shaft – NDE	A-2	--	--	--	--	272	392	443	490	558	--	--	NO GP	
	✓	✓	✓	✓	✓	M57	(C4140) Carbon Steel Shaft	A-2	--	--	--	--	--	--	--	4667	5004	3040	NO GP, SD661; STD on 2 Pole 500 Frame		
	✓	✓	✓	✓	✓	Y50	Special Shaft on Drive End	B	CF	CF	CF	CF	CF	CF	CF	CF	CF	CF	CF	CF	CF
✓	✓	✓	✓	✓	Y51	Special Shaft on Non Drive End	B	CF	CF	CF	CF	CF	CF	CF	CF	CF	CF	CF	CF	NO GP	

Note: See Weekly Stock List for updated lead times on delivery cases

Case A-1: Base Custom Delivery

Case A-2: One additional week

Case B: Three additional weeks

Legend

✓ Available

■ Standard

C Custom - See Custom Options

-- Not Available



Options Selection and Pricing

Custom Build Options (continued)

	1LE2	1MB2	1PC2	1LE6	1PC6 HPS	Codes	Description	Case	140	180	210	250	280	320	360	400	440	S449	500	Notes		
Frame																						
Short Codes	✓	✓	■	--	--	K33	Drip Cover	A-1	153	153	153	167	167	295	599	838	1550	1550	2970			
	✓	✓	■	--	--	K34	Lifting Hooks (No Drip Cover)	A-1	235	286	286	388	416	720	720	908	1001	1001	--	NO GP100A, SD661		
	✓	✓	--	■	■	K38	Provisions for Dowel Holes	A-1	--	--	--	--	435	483	530	614	915	915	■	NO GP100A		
	✓	✓	✓	✓	✓	K70	Rotation Arrow Bidirectional (Not for Uni-Directional)	A-1	142	142	142	142	142	142	142	142	142	142	142	150		
	✓	✓	✓	✓	✓	K71	Rotation Arrow Clockwise (From NDE)	A-1	142	142	142	142	142	142	142	142	142	142	142	150		
	✓	✓	✓	✓	✓	K72	Rotation Arrow Counterclockwise (From NDE)	A-1	142	142	142	142	142	142	142	142	142	142	142	150		
	✓	■	■	■	■	L20	Lifting Eyebolt	A-1	43	■	■	■	■	■	■	■	■	■	■	■	■	ONLY GP100
	✓	--	✓	✓	✓	L22	Stainless Steel Hardware (Includes T Drain SS)	A-1	203	203	203	203	203	251	308	380	468	641	650		NO GP100A	
	✓	✓	✓	✓	✓	L27	Ground Bolts - Qty 2	A-1	142	142	142	164	164	186	186	186	266	266	150		NO GP100A	
	✓	--	✓	✓	✓	L45	SST - Slot Breather Drain	A-1	161	161	161	234	234	234	307	307	307	307	307	300		NO GP100A
	✓	✓	✓	✓	✓	L46	CROUSE HINDS UL Approved Breather Drain	A-1	--	--	--	--	353	353	353	353	353	353	353	380		NO GP
	--	✓	--	--	--	L90	IP66 Ingress Protection		1021	1021	1066	1244	1289	1356	1556	1911	2088	--	--			
	✓	--	--	--	--	M09	Aluminum Fan	A-2	145	163	166	197	209	228	238	273	315	--	--		ONLY SD100	
	✓	--	✓	--	--	M10	Bronze Fan	A-1	546	546	706	752	941	1137	1190	1325	1830	--	--		NO GP100A	
	✓	✓	--	--	--	M28	Stainless Steel Eyebolt	A-1	161	161	161	161	161	161	161	161	161	161	161	--		NO GP100A
✓	✓	--	■	■	M39	Vertical Jacking Provisions	A-1	--	--	--	--	890	890	890	890	890	890	890	890		NO GP100A	
Rating Plates and Tagging																						
Short Codes	✓	✓	✓	✓	✓	M21	Additional Nameplate (without Logos)	A-1	164	164	164	164	164	164	164	164	164	164	164	200		
	✓	--	✓	✓	✓	M22	Class I, Division 2 Tag	A-1	322	322	322	322	322	322	322	322	322	322	322	150		NP GP
	✓	✓	✓	✓	✓	M23	Space Heaters Caution Plate	A-1	43	43	43	43	43	43	43	43	43	43	43	150		
	✓	✓	✓	✓	✓	M24	Lubrication Plate	A-1	104	104	104	104	104	104	104	104	104	104	104	130		
	✓	✓	✓	--	--	M25	Class II, Division 2	A-2	1021	1021	1066	1244	1289	1356	1556	1911	2088	2088	--			
	--	✓	--	--	--	M32	Class II, Group E Hazardous Area	A-2	512	512	727	743	828	995	1164	1332	1737	--	--			
	✓	✓	✓	✓	✓	Y80	Derate-Alt-Amb (Nameplate Change)	A-1	164	164	164	164	164	164	164	164	164	164	164	170		
	✓	✓	✓	✓	✓	Y82	Auxiliary n/p Max. 40 Characters (Aux Tag)	A-1	164	164	164	164	164	164	164	164	164	164	164	100		
Ambient																						
Short Codes	✓	--	✓	✓	✓	B27	+40C to -30C Ambient Temp	A-2	190	200	265	310	385	440	510	690	895	895	4200		NO GP	
	✓	--	✓	✓	✓	B28	+40C to -40C Ambient Temp	B	325	455	510	555	610	680	800	975	1175	1175	4200		NO GP	
	✓	--	✓	✓	✓	B29	+40C to -50C Ambient Temp	B	340	465	525	570	655	720	865	1075	1280	1280	4500		NO GP	

Note: See Weekly Stock List for updated lead times on delivery cases

Case A-1: Base Custom Delivery

Case A-2: One additional week

Case B: Three additional weeks

Legend

✓ Available

■ Standard

C Custom - See Custom Options

-- Not Available



Options Selection and Pricing

Custom Build Options (continued)

	1LE2	1MB2	1PC2	1LE6	1PC6 HPS	Codes	Description	Case	140	180	210	250	280	320	360	400	440	S449	500	Notes	
Mechanical Design and Accessories																					
Short Codes	✓	--	--	--	--	A66	ROBERTSHAW Vibration Detectors, Model 366-D8 120VAC	A-2	--	--	--	--	4216	4216	4216	5170	5170	5170	--		
	✓	✓	✓	✓	■	A67	Provision Only for Vibration Sensors (PMC/Beta)	A-2	--	--	--	--	3778	3778	3778	4574	4574	4574	1010	NO GP	
	✓	--	✓	--	--	G05	DYNAPAR Encoder HS35 1024 PPR	B	1750	1750	1750	1750	1750	1750	1750	1750	1750	1750	1750	--	NO GP, MS
	✓	--	✓	--	--	G06	C-Face Mounted SLIM Tach Encoder	B	3350	3720	4135	4595	6055	6070	6080	6230	6380	6380	--	--	NO GP, MS
	✓	--	--	--	--	H04	C-Face Mounted Brake	B	3480	3870	4300	4775	6915	13900	19170	29245	32495	32495	--	--	NO GP, MS
	✓	--	✓	✓	✓	K10	IEEE 841 Features	B	625	625	625	700	700	750	800	900	960	960	960	960	NO GP, MS, SD661, SD841
	--	--	✓	--	--	K20	API 610	B	--	250	250	460	460	460	580	920	920	--	--	--	
	✓	✓	--	--	--	M05	Larger Fan	A-2	--	--	--	--	--	--	320	320	360	--	--	--	NO GP, SD661; ONLY 4 Pole
	✓	--	--	--	--	M08	Separately Driven Fan	A-2	--	--	--	1120	1065	1160	1290	1325	1470	CF	--	--	NP GP, MS
	--	--	✓	--	--	M18	Non-Reverse Ratchet	B	--	--	350	400	500	700	1075	1720	2260	--	--	--	
	✓	✓	✓	--	--	M69	Precision Balance	A-1	190	190	190	218	218	248	248	313	313	610	--	--	
✓	✓	✓	--	--	M70	Extra Precision Balance	A-1	312	312	330	330	376	376	506	506	651	683	--	--		
Paint and Packaging																					
Short Codes	✓	✓	✓	✓	✓	B09	Export Packaging Sea Freight – Siemens Standard	A-1	98	125	125	125	230	290	360	740	1010	1010	2430		
	✓	✓	✓	✓	✓	B10	Export Packaging Special Export Box	A-2	CF	CF	CF	CF	CF	CF	CF	CF	CF	CF	CF	CF	
	✓	✓	✓	✓	✓	N01	2 Part Epoxy (Industrial-Coastal Low Salt)	B	430	550	585	675	830	925	945	1105	1320	1430	3210		
	✓	✓	✓	✓	✓	N02	3 Part Epoxy (Industrial-Coastal Moderate Salt)	B	520	655	710	820	1005	1120	1145	1340	1600	1735	3450		
	✓	✓	✓	✓	✓	N03	Primer Only	A-1	560	560	560	560	560	560	560	560	560	560	650		
	✓	✓	✓	✓	✓	N05	3 Part Epoxy (Coastal-Offshore High Salt)	B	625	830	880	1048	1255	1465	1675	1915	2160	2375	7120		
	✓	✓	✓	✓	✓	Y60	Special color (Provide RAL#)	A-2	556	556	556	556	556	556	556	556	556	556	557		

Note: See Weekly Stock List for updated lead times on delivery cases

Case A-1: Base Custom Delivery

Case A-2: One additional week

Case B: Three additional weeks

Legend

✓ Available

■ Standard

C Custom - See Custom Options

-- Not Available



Options Selection and Pricing

Custom Build Options (continued)

	1LE2	1MB2	1PC2	1LE6	1PC6 HPS	Codes	Description	Case	140	180	210	250	280	320	360	400	440	S449	500	Notes	
Documentation																					
Short Codes	✓	✓	✓	✓	✓	D05	Documentation in Spanish	A-1	0	0	0	0	0	0	0	0	0	0	0	0	
	✓	✓	✓	✓	✓	F00	Certificate of Compliance	A-1	300	300	300	300	300	300	300	300	300	300	300	300	
	✓	✓	✓	✓	✓	F03	Standard Performance Curves	A-1	747	747	747	747	747	747	747	747	747	747	747	450	
	✓	✓	✓	✓	✓	F07	Special Calculated Data	A-2	1195	1195	1195	1195	1195	1195	1195	1195	1195	1195	1195	750	
	✓	✓	✓	✓	✓	F40	Stall Time Curve (Thermal Limit Curve)	A-1	45	45	45	45	45	45	45	45	45	45	45	150	
	✓	✓	✓	✓	✓	F42	Standard Dimensional Sheet	A-1	45	45	45	45	45	45	45	45	45	45	45	150	
	✓	✓	✓	✓	✓	F43	Non-Standard Dimension Sheet	A-2	523	523	523	523	523	523	523	523	523	523	523	550	
	✓	✓	✓	✓	✓	F44	Conduit Box Dimension Sheet	A-1	45	45	45	45	45	45	45	45	45	45	45	150	
	✓	✓	✓	✓	✓	F45	Wiring Diagram	A-1	45	45	45	45	45	45	45	45	45	45	45	150	
	✓	✓	✓	✓	✓	F46	Instruction and Operation Manual in English	A-1	45	45	45	45	45	45	45	45	45	45	45	150	
	✓	✓	✓	✓	✓	F47	Renewal Parts	A-1	45	45	45	45	45	45	45	45	45	45	45	150	
	✓	✓	✓	✓	✓	F49	Performance Data Sheets	A-1	261	261	261	261	261	261	261	261	261	261	261	260	
	✓	✓	✓	✓	✓	F50	Customer Specific Data Sheets	A-2	523	523	523	523	523	523	523	523	523	523	523	550	
Tests																					
Short Codes	✓	✓	✓	✓	✓	F10	Routine Test Report	A-1	300	300	300	300	300	300	300	300	300	300	300	NO SDIEEE	
	✓	✓	✓	✓	✓	F12	Routine Test Report (Witnessed)	A-2	1628	1628	1628	1628	1643	1972	2360	2569	2778	3672	3700	NO SDIEEE	
	✓	✓	✓	✓	✓	F15	Complete Test	A-1	6749	6749	6749	6749	6812	7917	9680	11054	12010	13596	13600		
	✓	✓	✓	✓	✓	F17	Complete Test (Witnessed)	A-1	10123	10123	10123	10123	10217	11890	14519	16581	18015	20394	20400		
	✓	✓	✓	✓	✓	F20	Routine Test + Vibration	A-1	600	600	600	600	600	600	600	600	600	600	600	600	
	✓	✓	✓	✓	✓	F22	Routine Test + Vibration (Witnessed)	A-1	3256	3256	3256	3256	3286	3286	3286	3286	3286	3286	3286	3780	
	✓	✓	✓	✓	✓	F27	Performance Load Test (Curve Report)	A-1	5062	5062	5062	5062	5109	5938	7260	8290	9007	10197	7210		
	✓	✓	✓	✓	✓	F30	Noise Test	A-1	4144	4144	4144	4144	4183	4183	5378	5378	5378	5463	5500		
	✓	✓	✓	✓	✓	F32	Noise Test (Witnessed)	A-1	6512	6512	6512	6512	6573	7768	7768	7768	7768	7891	7900		
	✓	✓	✓	✓	✓	F36	Routine Test Report of Electrical Duplicate Design	A-1	300	300	300	300	300	300	300	300	300	300	300	300	
	✓	✓	✓	✓	✓	F37	Type Test Report of Electrical Duplicate Design	A-1	455	455	455	455	455	455	455	455	455	455	455	455	
	--	✓	--	--	--	F90	IEC EX Certification	B	512	512	727	743	828	995	1164	1332	1737	--	--		

Note: See Weekly Stock List for updated lead times on delivery cases
 Case A-1: Base Custom Delivery
 Case A-2: One additional week
 Case B: Three additional weeks

Legend

- ✓ Available
- Standard
- C Custom - See Custom Options
- Not Available



Typical Performance Details

GP100A/GP100

SIMOTICS General Purpose - 60Hz
GP100A/GP100
NEMA Premium
Aluminum Rotor

HP	FL RPM	Frame	Current (A)									KVA/ HP Code	Nominal Efficiency (%)			Power Factor			Torque			Locked Rotor Stall Time		NEMA Design	Approx. Weight (LBS)
			No Load			Full Load			Locked Rotor				1/2 Load (%)	3/4 Load (%)	Full Load (%)	1/2 Load (%)	3/4 Load (%)	Full Load (%)	Full Load Lb-FT	Locked Rotor TA/TN (%)	Break Down Tk/TN (%)	Hot (sec)	Cold (sec)		
			230V	460V	575V	230V	460V	575V	230V	460V	575V														
1	3520	143T	1.4	0.7	0.56	2.8	1.4	1.12	24	12	9.6	L	79.3	82.1	82.5	65.2	77.4	81.1	1.5	175	380	12	16	B	70
1	1755	143T	1.6	0.8	0.64	2.8	1.4	1.12	26	13	10.4	M	83.4	85.4	85.5	58.4	71.5	78.2	3	295	380	18	26	B	58
1	1165	145T	2	1	0.8	3.2	1.6	1.28	22	11	8.8	K	80.2	82.5	82.5	50.2	63.3	70.9	4.5	260	350	18	31	B	70
1	870	182T	3	1.5	1.2	4.2	2.1	1.68	18	9	7.2	J	77	80	81.5	36	47	56	6	160	280	50	68	B	86
1.5	3525	143T	2.2	1.1	0.88	4	2	1.6	38	19	15.2	M	80	83.2	84	64.2	77	83.6	2.2	270	450	14	19	B	75
1.5	1740	145T	3	1.1	0.88	4.2	2.1	1.68	38	19	15.2	M	85.8	87	86.5	58.5	71.8	77.3	4.5	330	420	15	21	B	69
1.5	1160	182T	2.8	1.4	1.12	4.8	2.4	1.92	30	15	12	J	85.3	87.6	87.5	48.4	58.4	66.9	6.8	205	330	34	46	B	101
1.5	865	184T	4.6	2.3	1.84	6	3	2.4	34	17	13.6	L	78.5	82	82.5	35	47	56	9	160	280	43	63	B	99
2	3515	145T	2.4	1.2	0.96	5	2.5	2	46	23	18.4	L	84	85.7	85.5	69	81.3	87.6	2.9	250	420	13	18	B	55
2	1740	145T	2.2	1.5	0.88	4.2	2.8	1.68	38	24	15.2	L	86	87.2	86.5	57.8	70.8	77.3	6	320	390	14	22	B	61
2	1160	184T	3.8	1.9	1.52	6.4	3.2	2.56	40	20	16	J	87.5	88.7	88.5	46.5	58.8	66.1	9.1	240	310	23	32	B	112
2	870	213T	4	2	1.6	6.6	3.3	2.64	32	16	12.8	H	84	84.5	84	51	63	67	12	170	290	22	38	B	126
3	3520	182T	3.4	1.7	1.36	7.6	3.8	3.04	60	30	24	J	84.17	86.3	86.5	69.5	79.8	85.5	4.4	185	380	20	30	B	81
3	1760	182T	4.2	2.1	1.68	8	4	3.2	66	33	26.4	K	87.8	89.4	89.5	59.5	71.7	78.5	9	235	360	17	29	B	85
3	1175	213T	5	2.5	2	8.6	4.3	3.44	64	32	25.6	K	87.8	89.3	89.5	52.1	65.4	73	13.4	265	470	23	35	B	155
3	870	215T	6	3	2.4	9.6	4.8	3.84	50	25	20	H	85.5	86.5	85.5	45	59	68	18	175	290	19	31	B	141
5	3505	184T	4	2	1.6	12	6	4.8	92	46	36.8	J	88.2	89.1	88.5	78.1	85.9	88.2	7.5	170	420	15	29	B	109
5	1755	184T	6	3	2.4	13	6.5	5.2	92	46	36.8	J	89.2	90	89.5	63.6	75.1	80.5	15	220	350	14	29	B	90
5	1165	215T	7	3.5	3.6	13.4	6.7	5.36	92	46	36.8	J	89.5	90.1	89.5	59.4	71.4	78.1	26.5	220	380	14	21	B	171
5	880	254T	11	5.5	4.4	17	8.5	6.8	66	33	26.4	G	85.5	87	86.5	43	54	61	30	155	210	65	115	B	218
7.5	3520	213T	6	3	2.4	17.6	8.8	7.04	126	63	50.4	H	89.6	90.1	89.5	78.5	86.8	89.2	11	180	490	17	30	B	209
7.5	1765	213T	10	5	4	19.4	9.7	7.76	126	63	50.4	H	90.73	91.7	91.7	60.5	72.3	78.9	22	270	450	25	42	B	165
7.5	1175	254T	10	5	4	20	10	8	126	63	50.4	H	91.1	91.5	91	58.4	70.2	77.2	33	165	260	26	45	B	249
7.5	875	256T	15.8	7.9	6.32	26	13	10.4	100	50	40	G	87	88	87.5	44	55	62	45	165	200	50	100	B	250
10	3515	215T	7	3.5	2.8	23	11.5	9.2	162	81	64.8	H	91	91.1	90.2	81.5	88.8	90.3	15	180	440	14	28	B	208
10	1755	215T	12.2	6.1	4.88	25	12.5	10	162	81	64.8	H	91.7	92.2	91.7	63.8	76.2	81.7	30	270	410	20	36	B	166
10	1175	256T	12.6	6.3	5.04	27	13.5	10.8	162	81	64.8	H	91.4	91.6	91	61	71.6	76.2	45	165	250	18	38	B	258
10	885	284T	22	11	8.8	34	17	13.6	162	81	64.8	H	88.2	89.8	90.2	42	53	61	59	160	240	15	30	B	418
15	3530	254T	10.2	5.1	4.08	35	17.5	14	232	116	92.8	G	90.7	91.3	91	80.6	87.4	88.2	22	210	260	24	48	B	301
15	1770	254T	17	8.5	6.8	38	19	15.2	232	116	92.8	G	92.3	92.8	92.4	64.5	74.7	80	44	185	235	21	33	B	242
15	1180	284T	22	11	8.8	42	21	16.8	232	116	92.8	G	90.9	91.8	91.7	53	66	73	67	150	240	22	48	B	409
15	885	286T	28	14	11.2	46	23	18.4	232	116	92.8	G	89.4	90.6	91	47	59	66	89	160	240	18	35	B	459
20	3515	256T	10.4	5.2	4.16	45	22.5	18	290	145	116	G	92.1	91.6	91	86.2	91.3	91.5	30	185	230	20	45	B	313
20	1770	256T	21	10.5	8.4	50	25	20	290	145	116	G	93.1	93.4	93	65.3	75.9	80.5	60	185	240	15	33	B	266
20	1180	286T	26	13	10.4	54	27	21.6	290	145	116	G	91.2	92	91.7	57	69	76	89	150	240	20	45	B	434
20	885	324T	36	18	14.4	64	32	25.6	290	145	116	G	90	90.8	91	46	58	65	119	140	200	15	35	B	616
25	3525	284TS	14	7	5.6	58	29	23.2	366	183	146.4	G	91.4	92.2	91.7	81	86	88	37	160	250	16	30	B	465
25	1775	284T	22	11	8.8	60	30	24	366	183	146.4	G	93.5	94	93.6	71	80	84	74	180	250	24	44	B	445
25	1185	324T	28	14	11.2	66	33	26.4	366	183	146.4	G	92.7	93.2	93	62	72	76	111	170	240	28	54	B	633
25	885	326T	44	22	17.6	80	40	32	366	183	146.4	G	90.4	91.2	91	48	59	65	149	150	200	22	40	B	663



Typical Performance Details

GP100A/GP100 (Continued)

SIMOTICS General Purpose - 60Hz GP100A/GP100 NEMA Premium Aluminum Rotor																									
HP	FL RPM	Frame	Current (A)									KVA/HP Code	Nominal Efficiency (%)			Power Factor			Torque			Locked Rotor Stall Time		NEMA Design	Approx. Weight (LBS)
			No Load			Full Load			Locked Rotor				1/2 Load (%)	3/4 Load (%)	Full Load (%)	1/2 Load (%)	3/4 Load (%)	Full Load (%)	Full Load Lb-FT	Locked Rotor TA/TN (%)	Break Down Tk/TN (%)	Hot (sec)	Cold (sec)		
			230V	460V	575V	230V	460V	575V	230V	460V	575V														
30	3530	286TS	17	8.5	6.8	68	34	27.2	436	218	174.4	G	91.4	92.2	91.7	84	89	90	45	160	250	16	30	B	424
30	1775	286T	24	12	9.6	70	35	28	436	218	174.4	G	93.9	94.1	93.6	73	82	85	89	180	250	24	44	B	456
30	1185	326T	30	15	12	78	39	31.2	436	218	174.4	G	93.1	93.5	93	61	73	77	133	170	220	26	52	B	658
30	885	364T	52	26	20.8	94	47	37.6	436	218	174.4	G	90.6	92	91.7	49	61	65	178	150	200	22	40	B	854
40	3535	324TS	24	12	9.6	90	45	36	580	290	232	G	94	94.1	93.6	80	87	89	60	150	250	22	45	B	608
40	1780	324T	30	15	12	92	46	36.8	580	290	232	G	94.3	94.1	94.1	75	83	86	118	180	230	22	45	B	636
40	1185	364T	38	19	15.2	98	49	39.2	580	290	232	G	94.4	94.6	94.1	68	77	81	177	190	220	29	55	B	828
40	885	365T	72	36	28.8	126	63	50.4	580	290	232	G	90.7	92	91.7	49	60	65	237	150	200	25	40	B	950
50	3535	326TS	30	15	12	110	55	44	726	363	290.4	G	93.8	94.1	93.6	82	89	91	74	150	250	18	37	B	593
50	1780	326T	40	20	16	116	58	46.4	726	363	290.4	G	94.8	95	94.5	72	81	85	148	170	230	22	45	B	700
50	1185	365T	48	24	19.2	124	62	49.6	726	363	290.4	G	94	94.3	94.1	67	76	80	222	190	220	29	55	B	863
50	885	404T	56	28	22.4	134	67	53.6	726	363	290.4	G	93	93.1	92.4	64	73	76	297	140	200	25	40	B	1116
60	3565	364TS	38	19	15.2	136	68	54.4	870	435	348	G	93.8	94.1	93.6	80	86	88	89	160	250	16	28	B	780
60	1780	364T	42	21	16.8	136	68	54.4	870	435	348	G	95.2	95.4	95	77	85	87	177	180	240	26	38	B	903
60	1185	404T	56	28	22.4	148	74	59.2	870	435	348	G	94.2	94.7	94.5	65	76	80	266	180	220	25	50	B	1047
60	885	405T	60	30	24	156	78	62.4	870	435	348	G	93	93.1	92.4	66	75	78	356	140	200	30	35	B	1182
75	3565	365TS	44	22	17.6	172	86	68.8	1086	543	434.4	G	93.7	94.3	94.1	81	86	88	111	160	260	16	27	B	888
75	1780	365T	50	25	20	170	85	68	1086	543	434.4	G	95.6	95.8	95.4	78	85	87	221	180	240	25	35	B	950
75	1185	405T	68	34	27.2	186	93	74.4	1086	543	434.4	G	94.7	94.9	94.5	68	77	80	332	180	220	33	45	B	1257
75	885	444T	74	37	29.6	188	94	75.2	1086	543	434.4	G	93.5	93.9	93.6	67	76	80	445	135	200	25	32	B	1557
100	3570	405TS	--	19	15.2	--	108	86.4	--	725	580	G	94.6	94.7	94.1	89	91	92	147	120	200	25	45	B	1097
100	1780	405T	--	30	24	--	113	90.4	--	725	580	G	95.8	96	95.4	80	86	87	295	180	200	25	35	B	1097
100	1185	444T	--	39	31.2	--	117	93.6	--	725	580	G	95.1	95.3	95	73	81	84	443	160	200	30	35	B	1550
100	885	445T	--	48	38.4	--	123	98.4	--	725	580	G	94.2	94.5	94.1	70	78	81	593	130	200	22	30	B	1697
125	3575	444TS	--	32	25.6	--	138	110.4	--	908	726.4	G	94.5	95.1	95	84	88	89	184	120	200	18	23	B	1381
125	1785	444T	--	45	36	--	143	114.4	--	908	726.4	G	95.4	95.6	95.4	78	84	86	368	160	200	20	25	B	1601
125	1185	445T	--	48	38.4	--	144	115.2	--	908	726.4	G	95.1	95.4	95	74	82	85	554	160	200	25	35	B	1766
125	885	447T	--	54	43.2	--	152	121.6	--	908	726.4	G	94.6	94.7	94.1	70	79	82	742	130	200	20	30	B	2018
150	3575	445TS	--	37	29.6	--	164	131.2	--	1085	868	G	94.2	95	95	84	89	90	220	120	200	15	18	B	1601
150	1785	445T	--	52	41.6	--	170	136	--	1085	868	G	95.7	96	95.8	78	84	86	441	150	200	20	30	B	1753
150	1190	447T	--	59	47.2	--	172	137.6	--	1085	868	G	95.6	96	95.8	73	82	85	662	140	200	28	43	B	2006
200	3575	445TS	--	44	29.6	--	216	131.2	--	1450	868	G	95.3	95.6	95.4	83	90	91	294	120	200	16	20	B	1916
200	1785	445T	--	73	41.6	--	228	136	--	1450	868	G	96.2	96.5	96.2	75	83	85	588	160	200	18	25	B	2083
200	1190	447T	--	73	47.2	--	227	137.6	--	1450	868	G	95.6	96.2	95.8	75	83	86	883	125	200	25	32	B	2451



Typical Performance Details

GP100A/GP100

SIMOTICS General Purpose - 60Hz GP100A/GP100 NEMA Premium+ Copper Rotor																									
HP	FL RPM	Frame	Current (A)									KVA/HP Code	Nominal Efficiency (%)			Power Factor			Torque			Locked Rotor Stall Time		NEMA Design	Approx. Weight (LBS)
			No Load			Full Load			Locked Rotor				1/2 Load (%)	3/4 Load (%)	Full Load (%)	1/2 Load (%)	3/4 Load (%)	Full Load (%)	Full Load Lb-FT	Locked Rotor TA/TN (%)	Break Down Tk/TN (%)	Hot (sec)	Cold (sec)		
			230V	460V	575V	230V	460V	575V	230V	460V	575V														
1	3550	143T	1.4	0.7	0.56	2.8	1.4	1.12	24	12	9.6	L	79.3	82.1	82.5	65	82.1	81.1	1.5	175	380	12	16	B	66
1	1775	143T	1.8	0.9	0.72	3	1.5	1.2	30	15	12	N	83	86	86.5	53	86	74	3	290	480	16	20	B	67
1	1175	145T	2	1	0.8	3.2	1.6	1.28	24	12	9.6	L	80.5	83.5	84	49	83.5	70	4.5	210	380	19	27	B	67
1.5	3550	143T	1.6	0.8	0.64	3.8	1.9	1.52	40	20	16	M	83	86	87.5	69	86	84	2.2	230	480	19	26	B	65
1.5	1770	145T	2.4	1.2	0.96	4.2	2.1	1.68	40	20	16	M	85	87	87.5	57	87	77	4.4	250	460	14	19	B	67
1.5	1180	182T	2.8	1.4	1.12	4.8	2.4	1.92	34	17	13.6	L	84.5	87	87.5	49	87	67	6.7	165	410	33	50	B	97
2	3550	145T	2.4	1.2	0.96	5.2	2.6	2.08	50	25	20	L	85	88	88.5	66	88	83	3	250	490	18	26	B	66
2	1765	145T	3.2	1.6	1.28	5.6	2.8	2.24	50	25	20	L	86	87.5	87.5	55	87.5	78	6	240	440	15	21	B	68
2	1180	184T	3.6	1.8	1.44	6	3	2.4	44	22	17.6	K	87.5	89	88.5	47	89	67	8.9	190	400	30	41	B	107
3	3565	182T	3	1.5	1.2	7.6	3.8	3.04	64	32	25.6	K	85.5	89	89.5	69	89	83	4.4	220	400	36	51	B	101
3	1770	182T	3.6	1.8	1.44	8	4	3.2	66	33	26.4	K	88.5	90	90.2	63	90	79	8.9	230	390	31	45	B	105
3	1180	213T	4.6	2.3	1.84	8.6	4.3	3.44	64	32	25.6	K	88.5	90	90.2	55	90	74	13	170	360	27	35	B	150
5	3550	184T	4.6	2.3	1.84	12.4	6.2	4.96	92	46	36.8	J	89	90.2	90.2	70	90.2	84	7.4	200	440	21	38	B	103
5	1770	184T	6.4	3.2	2.56	13.4	6.7	5.36	92	46	36.8	J	89.5	90	90.2	62	90	77	15	225	340	19	35	B	109
5	1180	215T	7	3.5	2.8	14	7	5.6	92	46	36.8	J	89	90.5	90.2	56	90.5	76	22	190	350	21	31	B	163
7.5	3560	213T	5.2	2.6	2.08	17	8.5	6.8	126	63	50.4	H	91	92	91.7	78	92	88	11	170	340	19	31	B	178
7.5	1775	213T	8	4	3.2	19	9.5	7.6	126	63	50.4	H	92	92.5	92.4	65	92.5	81	22	250	340	34	49	B	178
7.5	1180	254T	10	5	4	21	10.5	8.4	126	63	50.4	H	91.5	92.5	92.4	57	92.5	76	33	190	230	66	92	B	294
10	3555	215T	6.8	3.4	2.72	23	11.5	9.2	162	81	64.8	H	92	92.3	91.7	78	92.3	89	15	200	360	13	24	B	185
10	1770	215T	11	5.5	4.4	25	12.5	10	162	81	64.8	H	92	92.5	92.4	64	92.5	81	30	250	280	25	41	B	185
10	1185	256T	13	6.5	5.2	27	13.5	10.8	162	81	64.8	H	92	92.5	92.4	57	92.5	72	44	240	250	45	73	B	307
15	3565	254T	10	5	4	34	17	13.6	232	116	92.8	G	91	92	92.4	81	92	89	22	220	280	45	81	B	279
15	1780	254T	14.6	7.3	5.84	38	19	15.2	232	116	92.8	G	92.5	93.5	93	66	93.5	79	44	200	250	25	55	B	268
20	3560	256T	11	5.5	4.4	45	22.5	18	290	145	116	G	92	92.5	92.4	84	92.5	88	29	210	250	34	75	B	303
20	1780	256T	19	9.5	7.6	50	25	20	290	145	116	G	93	93.5	93.6	68	93.5	80	59	190	230	28	56	B	311

Introduction

Special Features

Motor Selection and Pricing

Options Selection and Pricing

Typical Performance Details

General Dimensions

MV449 Frame

Indexes



Typical Performance Details

SD100, SD100 IEEE

SIMOTICS Severe Duty - 60Hz SD100 / SD100 IEEE841/SD661 NEMA Premium Aluminum Rotor																											
HP	FL RPM	Frame	Current (A)									KVA/HP Code	Nominal Efficiency (%)			Power Factor			Torque			Locked Rotor Stall Time		NEMA Design	Approx. Weight (LBS)		
			No Load			Full Load			Locked Rotor				1/2 Load (%)	3/4 Load (%)	Full Load (%)	1/2 Load (%)	3/4 Load (%)	Full Load (%)	Full Load Lb-FT	Locked Rotor TA/TN (%)	Break Down Tk/TN (%)	Hot (sec)	Cold (sec)				
			230V	460V	575V	230V	460V	575V	230V	460V	575V																
1	3520	143T	1.4	0.7	0.56	2.8	1.4	1.12	24	12	9.6	L	79.3	82.1	82.5	65.2	77.4	81.1	1.5	175	380	12	16	B	85		
1	1755	143T	1.6	0.8	0.64	2.8	1.4	1.12	26	13	10.4	M	83.4	85.4	85.5	58.4	71.5	78.2	3	295	380	18	26	B	72		
1	1165	145T	2	1	0.8	3.2	1.6	1.28	22	11	8.8	K	80.2	82.5	82.5	50.2	63.3	70.9	4.5	260	350	18	31	B	70		
1	870	182T	3	1.5	1.2	4.2	2.1	1.68	18	9	7.2	J	77	80	81.5	36	47	56	6	160	280	50	68	B	106		
1.5	3525	143T	2.2	1.1	0.88	4	2	1.6	38	19	15.2	M	80	83.2	84	64.2	77	83.6	2.2	270	450	14	19	B	44		
1.5	1740	145T	2.2	1.1	0.88	4.2	2.1	1.68	38	19	15.2	M	85.8	87	86.5	58.5	71.8	77.3	4.5	330	420	15	21	B	83		
1.5	1160	182T	2.8	1.4	1.12	4.8	2.4	1.92	30	15	12	J	85.3	87.6	87.5	48.4	58.4	66.9	6.8	205	330	34	46	B	121		
1.5	865	184T	4.6	2.3	1.84	6	3	2.4	34	17	13.6	L	78.5	82	82.5	35	47	56	9	160	280	43	63	B	119		
2	3515	145T	2.4	1.2	0.96	5	2.5	2	46	23	18.4	L	84	85.7	85.5	69	81.3	87.6	2.9	250	420	13	18	B	69		
2	1740	145T	3	1.5	1.2	5.6	2.8	2.24	48	24	19.2	L	86	87.2	86.5	57.8	70.8	77.3	6	320	390	14	22	B	75		
2	1160	184T	3.8	1.9	1.52	6.4	3.2	2.56	40	20	16	J	87.5	88.7	88.5	46.5	58.8	66.1	9.1	240	310	23	32	B	133		
2	870	213T	4	2	1.6	6.6	3.3	2.64	32	16	12.8	H	84	84.5	84	51	63	67	12	170	290	22	38	B	145		
3	3520	182T	3.4	1.7	1.36	7.6	3.8	3.04	60	30	24	J	84.17	86.3	86.5	69.5	79.8	85.5	4.4	185	380	20	30	B	135		
3	1760	182T	4.2	2.1	1.68	8	4	3.2	66	33	26.4	K	87.8	89.4	89.5	59.5	71.7	78.5	9	235	360	17	29	B	132		
3	1175	213T	5	2.5	2	8.6	4.3	3.44	64	32	25.6	K	87.8	89.3	89.5	52.1	65.4	73	13.4	265	470	23	35	B	176		
3	870	215T	6	3	2.4	9.6	4.8	3.84	50	25	20	H	85.5	86.5	85.5	45	59	68	18	175	290	19	31	B	160		
5	3505	184T	4	2	1.6	12	6	4.8	92	46	36.8	J	88.2	89.1	88.5	78.1	85.9	88.2	7.5	170	420	15	29	B	129		
5	1755	184T	6	3	2.4	13	6.5	5.2	92	46	36.8	J	89.2	90	89.5	63.6	75.1	80.5	15	220	350	14	29	B	135		
5	1165	215T	7	3.5	3.6	13.4	6.7	5.36	92	46	36.8	J	89.5	90.1	89.5	59.4	71.4	78.1	26.5	220	380	14	21	B	191		
5	880	254T	11	5.5	4.4	17	8.5	6.8	66	33	26.4	G	85.5	87	86.5	43	54	61	30	155	210	65	115	B	247		
7.5	3520	213T	6	3	2.4	17.6	8.8	7.04	126	63	50.4	H	89.6	90.1	89.5	78.5	86.8	89.2	11	180	490	17	30	B	161		
7.5	1765	213T	10	5	4	19.4	9.7	7.76	126	63	50.4	H	90.73	91.7	91.7	60.5	72.3	78.9	22	270	450	25	42	B	175		
7.5	1175	254T	10	5	4	20	10	8	126	63	50.4	H	91.1	91.5	91	58.4	70.2	77.2	33	165	260	26	45	B	278		
7.5	875	256T	15.8	7.9	6.32	26	13	10.4	100	50	40	G	87	88	87.5	44	55	62	45	165	200	50	100	B	279		
10	3515	215T	7	3.5	2.8	23	11.5	9.2	162	81	64.8	H	91	91.1	90.2	81.5	88.8	90.3	15	180	440	14	28	B	218		
10	1755	215T	12.2	6.1	4.88	25	12.5	10	162	81	64.8	H	91.7	92.2	91.7	63.8	76.2	81.7	30	270	410	20	36	B	180		
10	1175	256T	12.6	6.3	5.04	27	13.5	10.8	162	81	64.8	H	91.4	91.6	91	61	71.6	76.2	45	165	250	18	38	B	385		
10	875	284T	18.2	9.1	7.28	30	15	12	162	81	64.8	H	89.4	90.9	91	50	61	69	60	150	220	15	30	B	361		
15	3530	254T	10.2	5.1	4.08	35	17.5	14	232	116	92.8	G	90.7	91.3	91	80.6	87.4	88.2	22	210	260	24	48	B	331		
15	1770	254T	17	8.5	6.8	38	19	15.2	232	116	92.8	G	92.3	92.8	92.4	64.5	74.7	80	44	185	235	21	33	B	286		
15	1180	284T	22	11	8.8	42	21	16.8	232	116	92.8	G	90.9	91.8	91.7	53	66	73	67	150	240	22	48	B	440		
15	875	286T	28	14	11.2	46	23	18.4	232	116	92.8	G	90.1	91.4	91	50	60	67	90	150	220	18	35	B	430		
20	3515	256T	10.4	5.2	4.16	45	22.5	18	290	145	116	G	92.1	91.6	91	86.2	91.3	91.5	30	185	230	20	45	B	343		
20	1770	256T	20.96	10.48	8.384	50	25	20	290	145	116	G	93.1	93.4	93	65.3	75.9	80.5	60	185	240	15	33	B	319		
20	1180	286T	26	13	10.4	54	27	21.6	290	145	116	G	91.2	92	91.7	57	69	76	89	150	240	20	45	B	462		
20	880	324T	36	18	14.4	62	31	24.8	290	145	116	G	90	91.2	91	50	61	67	119	140	200	15	35	B	567		
25	3525	284TS	16	8	6.4	58	29	23.2	366	183	146.4	G	92	92.2	91.7	80	85	88	37	160	250	16	30	B	396		
25	1775	284T	22	11	8.8	60	30	24	366	183	146.4	G	93.5	94	93.6	71	80	84	74	180	250	24	44	B	445		
25	1185	324T	28	14	11.2	66	33	26.4	366	183	146.4	G	92.7	93.2	93	62	72	76	111	170	240	28	54	B	623		
25	880	326T	44	22	17.6	76	38	30.4	366	183	146.4	G	89.2	90.5	90.2	50	61	68	149	150	200	22	40	B	600		



Typical Performance Details

SD100, SD100 IEEE (Continued)

SIMOTICS Severe Duty - 60Hz
SD100 / SD100 IEEE841/SD661
NEMA Premium
Aluminum Rotor

HP	FL RPM	Frame	Current (A)									KVA/ HP Code	Nominal Efficiency (%)			Power Factor			Torque			Locked Rotor Stall Time		NEMA Design	Approx. Weight (LBS)
			No Load			Full Load			Locked Rotor				1/2 Load (%)	3/4 Load (%)	Full Load (%)	1/2 Load (%)	3/4 Load (%)	Full Load (%)	Full Load Lb-FT	Locked Rotor TA/TN (%)	Break Down Tk/TN (%)	Hot (sec)	Cold (sec)		
			230V	460V	575V	230V	460V	575V	230V	460V	575V														
30	3525	286TS	19	9.5	7.6	68	34	27.2	436	218	174.4	G	92	92.2	91.7	84	89	90	45	160	250	16	30	B	430
30	1775	286T	24	12	9.6	70	35	28	436	218	174.4	G	93.9	94.1	93.6	73	82	85	89	180	250	24	44	B	478
30	1185	326T	30	15	12	78	39	31.2	436	218	174.4	G	93.1	93.5	93	64	73	77	133	170	220	26	52	B	654
30	885	364T	52	26	20.8	94	47	37.6	436	218	174.4	G	89.9	91.3	91	50	62	66	178	150	200	22	40	B	800
40	3535	324TS	24	12	9.6	90	45	36	580	290	232	G	94	94.1	93.6	80	87	89	60	150	250	22	45	B	539
40	1780	324T	30	15	12	92	46	36.8	580	290	232	G	94.3	94.1	94.1	75	83	86	118	180	230	22	45	B	632
40	1185	364T	36	18	14.4	98	49	39.2	580	290	232	G	94.4	94.1	94.1	70	79	81	177	190	220	29	55	B	839
40	885	365T	72	36	28.8	126	63	50.4	580	290	232	G	90.7	92	91.7	49	60	65	237	150	200	25	40	B	920
50	3535	326TS	30	15	12	110	55	44	726	363	290.4	G	93.8	94.1	93.6	82	89	91	74	150	250	18	37	B	573
50	1780	326T	38	19	15.2	116	58	46.4	726	363	290.4	G	94.8	95	94.5	74	82	85	148	170	230	22	45	B	700
50	1185	365T	48	24	19.2	124	62	49.6	726	363	290.4	G	94	94.3	94.1	67	76	80	222	190	220	29	55	B	883
50	885	404T	56	28	22.4	134	67	53.6	726	363	290.4	G	93	93.1	92.4	64	73	76	297	140	200	25	40	B	1116
60	3565	364TS	38	19	15.2	136	68	54.4	870	435	348	G	93.8	94.1	93.6	80	86	88	89	160	250	16	28	B	740
60	1780	364T	38	19	15.2	136	68	54.4	870	435	348	G	95.2	95.4	95	77	85	87	177	180	240	26	38	B	936
60	1185	404T	56	28	22.4	148	74	59.2	870	435	348	G	94.2	94.7	94.5	65	76	80	266	180	220	25	50	B	1100
60	885	405T	60	30	24	156	78	62.4	870	435	348	G	93	93.1	92.4	66	75	78	356	140	200	30	35	B	1182
75	3565	365TS	44	22	17.6	172	86	68.8	--	543	434.4	G	93.7	94.3	94.1	81	86	88	111	160	260	16	27	B	817
75	1780	365T	50	25	20	170	85	68	1086	543	434.4	G	95.6	95.8	95.4	78	85	87	221	180	240	25	35	B	1000
75	1185	405T	68	34	27.2	186	93	74.4	1086	543	434.4	G	94.7	94.9	94.5	68	77	80	332	180	220	33	45	B	1257
75	885	444T	74	37	29.6	188	94	75.2	1086	543	434.4	G	93.5	93.9	93.6	67	76	80	445	135	200	25	32	B	1557
100	3570	405TS	--	19	15.2	--	108	86.4	--	725	580	G	94.6	94.7	94.1	90	92	92	147	120	200	25	45	B	1097
100	1780	405T	--	30	24	--	113	90.4	--	725	580	G	95.8	96	95.4	80	86	87	295	180	200	25	35	B	1101
100	1185	444T	--	39	31.2	--	117	93.6	--	725	580	G	95.1	95.3	95	73	81	84	443	160	200	30	35	B	1550
100	885	445T	--	48	38.4	--	123	98.4	--	725	580	G	94.2	94.5	94.1	70	78	81	593	130	200	22	30	B	1697
125	3575	444TS	--	32	25.6	--	138	110.4	--	908	726.4	G	94.5	95.1	95	84	88	89	184	120	200	18	23	B	1454
125	1785	444T	--	45	36	--	143	114.4	--	908	726.4	G	95.4	95.6	95.4	78	84	86	368	160	200	20	25	B	1601
125	1185	445T	--	48	38.4	--	144	115.2	--	908	726.4	G	95.1	95.4	95	74	82	85	554	160	200	25	35	B	1766
125	885	447T	--	54	43.2	--	152	121.6	--	908	726.4	G	94.6	94.7	94.1	70	79	82	742	130	200	20	30	B	2018

Introduction

Special Features

Motor Selection and Pricing

Options Selection and Pricing

Typical Performance Details

General Dimensions

MV449 Frame

Indexes



Typical Performance Details

SD100, SD100 IEEE (Continued)

SIMOTICS Severe Duty - 60Hz
SD100 / SD100 IEEE841/SD661
NEMA Premium
Aluminum Rotor

HP	FL RPM	Frame	Current (A)									KVA/HP Code	Nominal Efficiency (%)			Power Factor			Torque			Locked Rotor Stall Time		NEMA Design	Approx. Weight (LBS)
			No Load			Full Load			Locked Rotor				1/2 Load (%)	3/4 Load (%)	Full Load (%)	1/2 Load (%)	3/4 Load (%)	Full Load (%)	Full Load Lb-FT	Locked Rotor TA/TN (%)	Break Down Tk/TN (%)	Hot (sec)	Cold (sec)		
			230V	460V	575V	230V	460V	575V	230V	460V	575V														
150	3575	445TS	--	37	29.6	--	164	131.2	--	1085	868	G	94.8	95.2	95	84	89	90	220	120	200	15	18	B	1601
150	1785	445T	--	52	41.6	--	170	136	--	1085	868	G	95.7	96	95.8	78	84	86	441	150	200	20	30	B	1753
150	1190	447T	--	59	47.2	--	172	137.6	--	1085	868	G	95.6	96	95.8	73	82	85	662	140	200	28	43	B	2006
150	885	449T	--	72	57.6	--	186	148.8	--	1085	868	G	0.941	0.945	0.941	0.67	0.76	0.8	890	130	200	20	30	B	2018
200	3575	445TS	--	44	35.2	--	216	172.8	--	1450	1160	G	95.3	95.6	95.4	88	90	91	294	120	200	16	20	B	1916
200	1785	445T	--	70	56	--	226	180.8	--	1450	1160	G	96.2	96.5	96.2	76	84	86	588	160	200	18	25	B	2083
200	1190	447T	--	73	58.4	--	227	181.6	--	1450	1160	G	95.6	96.2	95.8	75	83	86	883	125	200	25	32	B	2451
200	885	S449LS	--	78	62.4	--	240	192	--	1450	1160	G	95	95	94.5	71	79	83	1187	125	200	15	25	B	3200
250	3575	449TS	--	45	36	--	265	212	--	1825	1460	G	95.7	96	95.8	89	91	91	368	120	200	12	18	B	2272
250	1785	449T	--	90	72	--	278	222.4	--	2100	1680	H	96.1	96.3	96.2	78	85	87	735	140	200	18	25	A	2435
250	1190	449T	--	86	68.8	--	281	224.8	--	2050	1640	H	95.7	96	95.8	81	86	87	1104	120	200	20	25	A	2438
250	885	S449LS	--	109	87.2	--	303	242.4	--	1825	1460	G	94.5	94.8	94.5	70	78	82	1483	105	200	25	32	B	3220
300	3570	449TS	--	68	54.4	--	325	260	--	2200	1760	G	95.2	95.8	95.8	86	90	91	441	100	200	12	13	B	2200
300	1785	449T	--	114	91.2	--	338	270.4	--	2400	1920	H	96.1	96.3	96.2	75	83	86	882	140	200	22	30	A	2455
300	1185	S449LS	--	119	95.2	--	340	272	--	2400	1920	H	96	96.1	95.8	82	85	86	1329	105	200	26	33	A	3240
350	3570	S449SS	--	68	54.4	--	370	296	--	2550	2040	G	95.8	96.1	95.8	89	91	92	515	80	200	20	26	B	2890
350	1785	S449LS	--	115	92	--	390	312	--	2550	2040	G	95.8	96.3	96.2	77	84	86	1029	100	200	25	32	B	3550
400	3570	S449SS	--	80	64	--	422	337.6	--	2900	2320	G	94.6	96.1	95.8	89	92	93	588	80	200	17	24	B	3065
400	1785	S449LS	--	130	104	--	454	363.2	--	2900	2320	G	96	96.4	96.2	77	84	86	1176	100	200	21	26	B	3240



Typical Performance Details

SD100, SD100 IEEE

SIMOTICS Severe Duty - 60Hz
SD100 / SD100 IEEE841
NEMA Premium+
Copper Rotor

HP	FL RPM	Frame	Current (A)									KVA/HP Code	Nominal Efficiency (%)			Power Factor			Torque			Locked Rotor Stall Time		NEMA Design	Approx. Weight (LBS)
			No Load			Full Load			Locked Rotor				1/2 Load (%)	3/4 Load (%)	Full Load (%)	1/2 Load (%)	3/4 Load (%)	Full Load (%)	Full Load Lb-FT	Locked Rotor TA/TN (%)	Break Down Tk/TN (%)	Hot (sec)	Cold (sec)		
			230V	460V	575V	230V	460V	575V	230V	460V	575V														
1	3550	143T	1.4	0.7	0.56	2.8	1.4	1.12	24	12	9.6	L	79.3	82.1	82.5	65	77	81.1	1.5	175	380	12	16	B	0
1	1775	143T	1.8	0.9	0.72	3	1.5	1.2	30	15	12	N	83	86	86.5	53	65	74	3	290	480	16	20	B	81
1	1175	145T	2	1	0.8	3.2	1.6	1.28	24	12	9.6	L	80.5	83.5	84	49	61	70	4.5	210	380	19	27	B	81
1.5	3550	143T	1.6	0.8	0.64	3.8	1.9	1.52	40	20	16	M	83	86	87.5	69	79	84	2.2	230	480	19	26	B	70
1.5	1770	145T	2.4	1.2	0.96	4.2	2.1	1.68	40	20	16	M	85	87	87.5	57	69	77	4.4	250	460	14	19	B	70
1.5	1180	182T	2.8	1.4	1.12	4.8	2.4	1.92	34	17	13.6	L	84.5	87	87.5	49	61	67	6.7	165	410	33	50	B	117
2	3550	145T	2.4	1.2	0.96	5.2	2.6	2.08	50	25	20	L	85	88	88.5	66	77	83	3	250	490	18	26	B	80
2	1765	145T	3.2	1.6	1.28	5.6	2.8	2.24	50	25	20	L	86	87.5	87.5	55	69	78	6	240	440	15	21	B	81
2	1180	184T	3.6	1.8	1.44	6	3	2.4	44	22	17.6	K	87.5	89	88.5	47	59	67	8.9	190	400	30	41	B	127
3	3565	182T	3	1.5	1.2	7.6	3.8	3.04	64	32	25.6	K	85.5	89	89.5	69	79	83	4.4	220	400	36	51	B	105
3	1770	182T	3.6	1.8	1.44	8	4	3.2	66	33	26.4	K	88.5	90	90.2	63	73	79	8.9	230	390	31	45	B	105
3	1180	213T	4.6	2.3	1.84	8.6	4.3	3.44	64	32	25.6	K	88.5	90	90.2	55	67	74	13	175	360	27	35	B	165
5	3550	184T	4.6	2.3	1.84	12.4	6.2	4.96	92	46	36.8	J	89	90.2	90.2	70	80	84	7.4	200	440	21	38	B	123
5	1770	184T	6.4	3.2	2.56	13.4	6.7	5.36	92	46	36.8	J	89.5	90	90.2	62	72	77	15	225	340	19	35	B	115
5	1180	215T	7	3.5	2.8	14	7	5.6	92	46	36.8	J	89	90.5	90.2	56	68	76	22	190	350	21	31	B	184
7.5	3560	213T	5.2	2.6	2.08	17	8.5	6.8	126	63	50.4	H	91	92	91.7	78	86	88	11	170	340	19	31	B	191
7.5	1775	213T	8	4	3.2	19	9.5	7.6	126	63	50.4	H	92	92.5	92.4	65	76	81	22	250	340	34	49	B	198
7.5	1180	254T	10	5	4	21	10.5	8.4	126	63	50.4	H	91.5	92.5	92.4	57	67	76	33	190	230	66	92	B	323
10	3555	215T	6.8	3.4	2.72	23	11.5	9.2	162	81	64.8	H	92	92.3	91.7	78	86	89	15	200	360	13	24	B	189
10	1770	215T	11	5.5	4.4	25	12.5	10	162	81	64.8	H	92	92.5	92.4	64	75	81	30	250	280	25	41	B	206
10	1185	256T	13	6.5	5.2	27	13.5	10.8	162	81	64.8	H	92	92.5	92.4	57	68	72	44	240	250	45	73	B	330
15	3565	254T	10	5	4	34	17	13.6	232	116	92.8	G	91	92	92.4	81	87	89	22	220	280	45	81	B	309
15	1780	254T	14.6	7.3	5.84	38	19	15.2	232	116	92.8	G	92.5	93.5	93	66	76	79	44	200	250	25	55	B	295
20	3560	256T	11	5.5	4.4	45	22.5	18	290	145	116	G	92	92.5	92.4	84	88	88	29	210	250	34	75	B	333
20	1780	256T	19	9.5	7.6	50	25	20	290	145	116	G	93	93.5	93.6	68	78	80	59	190	230	28	56	B	341

Introduction

Special Features

Motor Selection and Pricing

Options Selection and Pricing

Typical Performance Details

General Dimensions

MV449 Frame

Indexes



Typical Performance Details

SD200

SIMOTICS Severe Duty - 60Hz
SD200
NEMA Premium

HP	FL RPM	Frame	Current (A)						KVA/HP Code	Nominal Efficiency (%)			Power Factor			Torque			Locked Rotor Stall Time		NEMA Design	Approx. Weight (LBS)
			No Load		Full Load		Locked Rotor	1/2 Load (%)		3/4 Load (%)	Full Load (%)	1/2 Load (%)	3/4 Load (%)	Full Load (%)	Full Load Lb-FT	Locked Rotor TA/TN (%)	Break Down Tk/TN (%)	Hot (sec)	Cold (sec)			
			460V	575V	460V	575V	460V													575V		
350	1190	5010	140	112	410	328	2550	2040	G	96.6	96.6	96.2	74.3	81.5	84.1	1543	270	250	30	35	B	4387
400	3585	509S	85	70	430	345	2900	2320	G	96	96.4	96.5	85.1	89.6	90.8	585	190	230	23	28	B	4219
400	1790	509	140	112	460	368	2900	2320	G	96.2	96.7	96.5	76.3	81.8	84.4	1174.6	230	250	19	23	B	4105
400	1190	5011	160	128	470	376	2900	2320	G	96.6	96.6	96.2	74.3	81.5	84.1	1763.5	270	250	30	35	B	4529
450	3585	5010S	100	80	480	385	3250	2600	G	96	96.4	96.5	85.1	89.6	90.8	659.3	190	230	23	28	B	4357
450	1790	5010	150	120	515	412	3250	2600	G	96.4	96.7	96.5	76.7	82.7	84.8	1325.3	230	250	17	21	B	4302
450	1190	L5011	170	136	525	420	3250	2600	G	96.6	96.6	96.2	74.3	81.5	84.1	1984	270	250	30	35	B	5083
500	3585	5011S	105	84	535	430	3625	2900	G	96	96.4	96.5	85.1	89.6	90.8	732.5	190	230	19	24	B	4504
500	1790	5011	160	128	570	456	3625	2900	G	96.5	96.8	96.7	78.2	85.3	84.9	1469.2	230	250	18	22	B	4509
500	1190	5012	185	148	580	464	3625	2900	G	96.6	96.6	96.2	74.3	81.5	84.1	2204.4	270	250	30	35	B	5289
600	3585	5012S	145	115	650	520	4250	3400	G	96.3	96.8	96.7	80.6	87	89.1	877.7	190	230	17	22	NA	4936
600	1790	5012	190	152	686	548.8	4400	3520	G	96.6	96.9	96.7	77.5	83.6	84.7	1767.6	230	250	19	23	NA	4993
600	1190	5013	245	196	695	556	4518	3614	G	96.6	96.6	96.2	74.3	81.5	84.1	2644.9	270	250	30	35	NA	5391
700	3585	5013S	160	128	750	600	5285	4228	G	94.8	95.6	95.8	86.5	90.4	91.1	1025.5	250	290	23	28	NA	5538
700	1790	5013	305	244	830	664	5395	4316	G	97.3	97.2	96.7	81.2	85.7	81.7	2056.3	230	250	18	22	NA	5592
800	3585	5013S	210	170	870	680	6300	5040	G	95.1	96	96.2	82.4	87.7	89.4	1172	250	290	19	24	NA	5798
800	1790	5013	335	268	920	736	5980	4784	G	97.4	97.2	96.7	80.9	85.6	84.2	2349.9	230	250	17	21	NA	5840
900	3585	5013S	225	180	980	785	7100	5700	G	95.1	96	96.2	82.4	87.7	89.4	1320	250	290	17	22	NA	6098



Typical Performance Details

XP100, XP100 ID1

SIMOTICS Explosion Proof – 60Hz
XP100 / XP100 ID1
NEMA Premium

HP	FL RPM	Frame	Current (A)									KVA/ HP Code	Nominal Efficiency (%)			Power Factor			Torque			Locked Rotor Stall Time		NEMA Design	Approx. Weight (LBS)
			No Load			Full Load			Locked Rotor				1/2 Load (%)	3/4 Load (%)	Full Load (%)	1/2 Load (%)	3/4 Load (%)	Full Load (%)	Full Load Lb-FT	Locked Rotor TA/TN (%)	Break Down Tk/TN (%)	Hot (sec)	Cold (sec)		
			230V	460V	575V	230V	460V	575V	230V	460V	575V														
1	1760	143T	1.4	0.7	0.56	2.8	1.4	1.12	27.4	13.7	10.96	M	83.4	85.4	85.5	58.4	71.5	78.2	3	295	380	18	26	B	77
1	1165	145T	2	1	0.8	3.2	1.6	1.28	22	11	8.8	K	80.2	82.5	82.5	50.2	63.3	70.9	4.5	260	350	18	31	B	88
1	870	182T	3	1.5	1.2	4.2	2.1	1.68	18	9	7.2	J	77	80	81.5	36	47	56	8	160	280	50	68	B	105
1.5	3525	143T	2.2	1.1	0.88	4	2	1.6	38	19	15.2	M	80	83.2	84	64.2	77	83.6	2.2	270	450	14	19	B	55
1.5	1740	145T	2.2	1.1	0.88	4.2	2.1	1.68	38	19	15.2	M	85.8	87	86.5	58.5	71.8	77.3	4.5	330	420	15	21	B	88
1.5	1160	182T	2.8	1.4	1.12	4.8	2.4	1.92	32	16	12.8	K	85.3	87.6	87.5	48.4	58.4	66.9	6.8	205	330	34	46	B	105
1.5	865	184T	4.6	2.3	1.84	6	3	2.4	34	17	13.6	L	78.5	82	82.5	35	47	56	12	160	280	43	63	B	125
2	3515	145T	2.4	1.2	0.96	5	2.5	2	46	23	18.4	L	84	85.7	85.5	69	81.3	87.6	2.9	250	420	13	18	B	65
2	1740	145T	3	1.5	1.2	5.4	2.7	2.16	48	24	19.2	L	86	87.2	86.5	57.8	70.8	77.3	6	320	390	14	22	B	88
2	1160	184T	3.8	1.9	1.52	6.4	3.2	2.56	40	20	16	J	87.5	88.7	88.5	46.5	58.8	66.1	9.1	240	310	23	32	B	125
2	870	213T	4	2	1.6	6.6	3.3	2.64	32	16	12.8	H	84	84.5	84	51	63	67	16	170	290	22	38	B	161
3	3520	182T	3.4	1.7	1.36	7.6	3.8	3.04	60	30	24	J	84.17	86.3	86.5	69.5	79.8	85.5	4.4	185	380	20	30	B	110
3	1760	182T	4.2	2.1	1.68	8	4	3.2	66	33	26.4	K	87.8	89.4	89.5	59.5	71.7	78.5	9	235	360	17	29	B	120
3	1175	213T	5	2.5	2	8.6	4.3	3.44	64	32	25.6	K	87.8	89.3	89.5	52.1	65.4	73	13.4	265	470	23	35	B	175
3	870	215T	6	3	2.4	9.6	4.8	3.84	50	25	20	H	85.5	86.5	85.5	45	59	68	24	175	290	19	31	B	173
5	3505	184T	4	2	1.6	12	6	4.8	92	46	36.8	J	88.2	89.1	88.5	78.1	85.9	88.2	7.5	170	420	15	29	B	105
5	1755	184T	6	3	2.4	12.8	6.4	5.12	100	50	40	J	89.2	90	89.5	63.6	75.1	80.5	15	220	350	14	29	B	125
5	1165	215T	7	3.5	3.6	13.4	6.7	5.36	92	46	36.8	J	89.5	90.1	89.5	59.4	71.4	78.1	26.5	220	380	14	21	B	180
5	880	254T	11	5.5	4.4	17.6	8.8	7.04	66	33	26.4	G	85.5	87	86.5	43	54	61	41	155	210	65	115	B	270
7.5	3520	213T	6	3	2.4	17.6	8.8	7.04	126	63	50.4	H	89.6	90.1	89.5	78.5	86.8	89.2	11	180	490	17	30	B	165
7.5	1765	213T	10	5	4	19.4	9.7	7.76	126	63	50.4	H	90.73	91.7	91.7	60.5	72.3	78.9	22	270	450	25	42	B	192
7.5	1175	254T	10	5	4	20	10	8	126	63	50.4	H	91.1	91.5	91	58.4	70.2	77.2	33	165	260	26	45	B	272
7.5	875	256T	15.8	7.9	6.32	25	12.5	10	100	50	40	G	87	88	87.5	0.44	0.55	0.62	61	165	200	50	100	B	300
10	3515	215T	7	3.5	2.8	23	11.5	9.2	162	81	64.8	H	91	91.1	90.2	81.5	88.8	90.3	15	180	440	14	28	B	185
10	1755	215T	12.2	6.1	4.88	25	12.5	10	162	81	64.8	H	91.7	92.2	91.7	63.8	76.2	81.7	30	270	410	20	36	B	200
10	1175	256T	12.6	6.3	5.04	27	13.5	10.8	162	81	64.8	H	91.4	91.6	91	61	71.6	76.2	45	165	250	18	38	B	308
10	885	284T	22	11	8.8	34	17	13.6	162	81	64.8	H	88.2	89.8	90.2	42	53	61	59	160	240	15	30	B	486
15	3530	254T	10.2	5.1	4.08	35	17.5	14	232	116	92.8	G	90.7	91.3	91	80.6	87.4	88.2	22	210	260	24	48	B	283
15	1770	254T	17	8.5	6.8	38	19	15.2	232	116	92.8	G	92.3	92.8	92.4	64.5	74.7	80	44	185	235	21	33	B	315
15	1180	284T	22	11	8.8	42	21	16.8	232	116	92.8	G	90.9	91.8	91.7	53	66	73	67	150	240	22	48	B	484
15	885	286T	28	14	11.2	46	23	18.4	232	116	92.8	G	89.4	90.6	91	47	59	66	89	160	240	18	35	B	531
20	3515	256T	10.4	5.2	4.16	45	22.5	18	290	145	116	G	92.1	91.6	91	86.2	91.3	91.5	30	185	230	20	45	B	308
20	1770	256T	20.96	10.48	8.38	50	25	20	290	145	116	G	93.1	93.4	93	65.3	75.9	80.5	60	185	240	15	33	B	345
20	1180	286T	26	13	10.4	54	27	21.6	290	145	116	G	91.2	92	91.7	57	69	76	89	150	240	20	45	B	509
20	885	324T	36	18	14.4	64	32	25.6	290	145	116	G	90	90.8	91	46	58	65	119	140	200	15	35	B	636
25	3525	284TS	14	7	5.6	58	29	23.2	366	183	146.4	G	91.4	92.2	91.7	81	86	88	37	160	250	16	30	B	526
25	1775	284T	22	11	8.8	60	30	24	366	183	146.4	G	93.5	94	93.6	71	80	84	74	180	250	24	44	B	460
25	1185	324T	28	14	11.2	66	33	26.4	366	183	146.4	G	92.7	93.2	93	62	72	76	111	170	240	28	54	B	805
25	885	326T	44	22	17.6	80	40	32	366	183	146.4	G	90.4	91.2	91	48	59	65	149	150	200	22	40	B	683



Typical Performance Details

XP100, XP100 ID1 (Continued)

SIMOTICS Explosion Proof – 60Hz XP100 / XP100 ID1 NEMA Premium																									
HP	FL RPM	Frame	Current (A)									KVA/HP Code	Nominal Efficiency (%)			Power Factor			Torque			Locked Rotor Stall Time		NEMA Design	Approx. Weight (LBS)
			No Load			Full Load			Locked Rotor				1/2 Load (%)	3/4 Load (%)	Full Load (%)	1/2 Load (%)	3/4 Load (%)	Full Load (%)	Full Load Lb-FT	Locked Rotor TA/TN (%)	Break Down Tk/TN (%)	Hot (sec)	Cold (sec)		
			230V	460V	575V	230V	460V	575V	230V	460V	575V														
30	3530	286TS	17	8.5	6.8	68	34	27.2	436	218	174.4	G	91.4	92.2	91.7	84	89	90	45	160	250	16	30	B	521
30	1775	286T	24	12	9.6	70	35	28	454	227	181.6	G	93.9	94.1	93.6	73	82	85	89	180	250	24	44	B	493
30	1185	326T	30	15	12	78	39	31.2	436	218	174.4	G	93.1	93.5	93	61	73	77	133	170	220	26	52	B	685
30	885	364T	36	18	14.4	82	41	32.8	420	210	168	G	90.6	92	91.7	49	61	65	178	150	200	22	40	B	860
40	3535	324TS	24	12	9.6	90	45	36	580	290	232	G	94	94.1	93.6	80	87	89	60	150	250	22	45	B	610
40	1780	324T	30	15	12	92	46	36.8	580	290	232	G	94.3	94.1	94.1	75	83	86	118	180	230	22	45	B	653
40	1185	364T	38	19	15.2	98	49	39.2	580	290	232	G	94.4	94.6	94.1	68	77	81	177	190	220	29	55	B	606
40	885	365T	72	36	28.8	126	63	50.4	580	290	232	G	93	93.1	91.7	49	60	65	237	150	200	25	40	B	940
50	3535	326TS	30	15	12	110	55	44	726	363	290.4	G	93.8	94.1	93.6	82	89	91	74	150	250	18	37	B	600
50	1780	326T	38	19	15.2	116	58	46.4	768	384	307.2	G	94.8	95	94.5	74	82	85	148	170	230	22	45	B	695
50	1185	365T	48	24	19.2	124	62	49.6	726	363	290.4	G	94	94.3	94.1	67	76	80	222	190	220	29	55	B	850
50	885	404T	56	28	22.4	134	67	53.6	726	363	290.4	G	93	93.1	92.4	64	73	76	297	140	200	25	40	B	1050
60	3565	364TS	38	19	15.2	136	68	54.4	870	435	348	G	93.8	94.1	93.6	80	86	88	89	160	250	16	28	B	790
60	1780	364T	42	21	16.8	136	68	54.4	870	435	348	G	95.2	95.4	95	77	85	87	177	180	240	26	38	B	890
60	1185	404T	56	28	22.4	148	74	59.2	870	435	348	G	94.2	94.7	94.5	65	76	80	266	180	220	25	50	B	1055
60	885	405T	60	30	24	156	78	62.4	870	435	348	G	93	93.1	92.4	66	75	78	356	140	200	30	35	B	1050
75	3565	365TS	44	22	17.6	172	86	68.8	1086	543	434.4	G	93.7	94.3	94.1	81	86	88	111	160	260	16	27	B	945
75	1780	365T	50	25	20	170	85	68	1086	543	434.4	G	95.6	95.8	95.4	78	85	87	221	180	240	25	35	B	947
75	1185	405T	68	34	27.2	186	93	74.4	1086	543	434.4	G	94.7	94.9	94.5	68	77	80	332	180	220	33	45	B	1025
75	885	444T	74	37	29.6	188	94	75.2	1086	543	434.4	G	93.5	93.9	93.6	67	76	80	445	135	200	25	32	B	1551
100	3570	405TS	38	19	15.2	216	108	86.4	1450	725	580	G	94.6	94.7	94.1	90	92	92	147	120	200	25	45	B	1020
100	1780	405T	60	30	24	226	113	90.4	1450	725	580	G	95.8	96	95.4	80	86	87	295	180	200	25	35	B	1189
100	1185	444T	78	39	31.2	234	117	93.6	1450	725	580	G	95.1	95.3	95	73	81	84	443	160	200	30	35	B	1551
100	885	445T	96	48	38.4	246	123	98.4	1450	725	580	G	94.2	94.5	94.1	70	78	81	593	130	200	22	30	B	1770
125	3575	444TS	64	32	25.6	276	138	110.4	1816	908	726.4	G	94.5	95.1	95	84	88	89	184	120	200	18	23	B	1450
125	1785	444T	90	45	36	286	143	114.4	1816	908	726.4	G	95.4	95.6	95.4	78	84	86	368	160	200	20	25	B	1659
125	1185	445T	96	48	38.4	288	144	115.2	1816	908	726.4	G	95.1	95.4	95	74	82	85	554	160	200	25	35	B	1771
125	885	447T	108	54	43.2	304	152	121.6	1816	908	726.4	G	94.6	94.7	94.1	70	79	82	742	130	200	20	30	B	2029
150	3575	445TS	74	37	29.6	328	164	131.2	2170	1085	868	G	94.8	95.2	95	84	89	90	220	120	200	15	18	B	1611
150	1785	445T	104	52	41.6	340	170	136	2170	1085	868	G	95.7	96	95.8	78	84	86	441	150	200	20	30	B	1934
150	1190	447T	118	59	47.2	344	172	137.6	2170	1085	868	G	95.6	96	95.8	73	82	85	662	140	200	28	43	B	2051
150	885	449T	122	61	48.8	360	180	144	2170	1085	868	G	94.3	94.5	94.1	72	80	83	890	130	200	20	25	B	2508
200	3575	445TS	88	44	35.2	432	216	172.8	2900	1450	1160	G	95.3	95.6	95.4	88	90	91	294	120	200	16	20	B	2250
200	1785	445T	146	73	58.4	456	228	182.4	2900	1450	1160	G	96.2	96.5	96.2	75	83	85	588	160	200	18	25	B	2503
200	1190	447T	146	73	58.4	454	227	181.6	2900	1450	1160	G	95.6	96.2	95.8	75	83	86	883	125	200	25	32	B	2450
200	885	5449LS	156	78	62.4	480	240	192	2900	1450	1160	G	95	95	94.5	71	79	83	1187	125	200	15	25	B	2450
250	3575	449TS	90	45	36	530	265	212	3650	1825	1460	G	95.7	96	95.8	89	91	91	368	120	200	12	18	B	2300
250	1785	449T	180	90	72	556	278	222.4	4200	2100	1680	H	96.1	96.3	96.2	78	85	87	735	140	200	18	25	A	2490
250	1190	449T	172	86	68.8	562	281	224.8	4100	2050	1640	H	95.7	96	95.8	81	86	87	1104	120	200	20	25	A	2498
300	3570	449TS	136	68	54.4	650	325	260	4400	2200	1760	G	95.2	95.8	95.8	86	90	91	441	100	200	12	13	B	2300
300	1785	449T	228	114	91.2	676	338	270.4	4800	2400	1920	H	96.1	96.3	96.2	75	83	86	882	140	200	22	30	A	2350



Typical Performance Details

LP100

SIMOTICS Definite Purpose – 60Hz LP100 NEMA Premium Solid Shaft Vertical Motors																									
HP	FL RPM	Frame	Current (A)									KVA/HP Code	Nominal Efficiency (%)			Power Factor			Torque			Locked Rotor Stall Time		NEMA Design	Approx. Weight (LBS)
			No Load			Full Load			Locked Rotor				1/2 Load (%)	3/4 Load (%)	Full Load (%)	1/2 Load (%)	3/4 Load (%)	Full Load (%)	Full Load Lb-FT	Locked Rotor TA/TN (%)	Break Down Tk/TN (%)	Hot (sec)	Cold (sec)		
			230V	460V	575V	230V	460V	575V	230V	460V	575V														
3	3520	182LP	3.4	1.7	1.36	7.6	3.8	3.04	60	30	24	J	84.17	86.3	86.5	69.5	79.8	85.5	4.4	185	380	20	30	B	118
3	1760	182LP	4.2	2.1	1.68	8	4	3.2	66	33	26.4	K	87.8	89.4	89.5	59.5	71.7	78.5	9	235	360	17	29	B	129
3	1175	213LP	5	2.5	2	8.6	4.3	3.44	64	32	25.6	K	87.8	89.3	89.5	52.1	65.4	73	13.4	265	470	23	35	B	192
5	3505	184LP	4	2	1.6	12	6	4.8	92	46	36.8	J	88.2	89.1	88.5	78.1	85.9	88.2	7.5	170	420	15	29	B	130
5	1755	184LP	6	3	2.4	13	6.5	5.2	92	46	36.8	J	89.2	90	89.5	63.6	75.1	80.5	15	220	350	14	29	B	135
5	1165	215LP	7	3.5	3.6	13.4	6.7	5.36	92	46	36.8	J	89.5	90.1	89.5	59.4	71.4	78.1	26.5	220	380	14	21	B	204
7.5	3520	213LP	6	3	2.4	17.6	8.8	7.04	126	63	50.4	H	89.6	90.1	89.5	78.5	86.8	89.2	11	180	490	17	30	B	188
7.5	1765	213LP	10	5	4	19.4	9.7	7.76	126	63	50.4	H	90.73	91.7	91.7	60.5	72.3	78.9	22	270	450	25	42	B	212
7.5	1175	254LP	10	5	4	20	10	8	126	63	50.4	H	91.1	91.5	91	58.4	70.2	77.2	33	165	260	26	45	B	294
10	3515	215LP	7	3.5	2.8	23	11.5	9.2	162	81	64.8	H	91	91.1	90.2	81.5	88.8	90.3	15	180	440	14	28	B	202
10	1755	215LP	12.2	6.1	4.88	25	12.5	10	162	81	64.8	H	91.7	92.2	91.7	63.8	76.2	81.7	30	270	410	20	36	B	220
10	1175	256LP	12.6	6.3	5.04	27	13.5	10.8	162	81	64.8	H	91.4	91.6	91	61	71.6	76.2	45	165	250	18	38	B	310
15	3530	254LP	10.2	5.1	4.08	35	17.5	14	232	116	92.8	G	90.7	91.3	91	80.6	87.4	88.2	22	210	260	24	48	B	309
15	1770	254LP	17	8.5	6.8	38	19	15.2	232	116	92.8	G	92.3	92.8	92.4	64.5	74.7	80	44	185	235	21	33	B	315
15	1180	284LPH	22	11	8.8	42	21	16.8	232	116	92.8	G	90.9	91.8	91.7	53	66	73	67	150	240	22	48	B	601
20	3515	256LP	10.4	5.2	4.16	45	22.5	18	290	145	116	G	92.1	91.6	91	86.2	91.3	91.5	30	185	230	20	45	B	337
20	1770	256LP	21	10.5	8.4	50	25	20	290	145	116	G	93.1	93.4	93	65.3	75.9	80.5	60	185	240	15	33	B	342
20	1180	286LPH	26	13	10.4	54	27	21.6	290	145	116	G	91.2	92	91.7	57	69	76	89	150	240	20	45	B	656
25	3525	284LPH	16	8	6.4	58	29	23.2	366	183	146.4	G	92	92.2	91.7	80	85	88	37	160	250	16	30	B	559
25	1775	284LPH	22	11	8.8	60	30	24	366	183	146.4	G	93.5	94	93.6	71	80	84	74	180	250	24	44	B	640
25	1185	324LP	28	14	11.2	66	33	26.4	366	183	146.4	G	92.7	93.2	93	62	72	76	111	170	240	28	54	B	884
30	3525	286LPH	19	9.5	7.6	68	34	27.2	436	218	174.4	G	92	92.2	91.7	84	89	90	45	160	250	16	30	B	591
30	1775	286LPH	24	12	9.6	70	35	28	436	218	174.4	G	93.9	94.1	93.6	73	82	85	89	180	250	24	44	B	649
30	1185	326LP	30	15	12	78	39	31.2	436	218	174.4	G	93.1	93.5	93	64	73	77	133	170	220	26	52	B	920
40	3535	324LP	24	12	9.6	90	45	36	580	290	232	G	94	94.1	93.6	80	87	89	60	150	250	22	45	B	784
40	1780	324LP	30	15	12	92	46	36.8	580	290	232	G	94.3	94.1	94.1	75	83	86	118	180	230	22	45	B	848
40	1185	364LP	36	18	14.4	98	49	39.2	580	290	232	G	94.4	94.1	94.1	70	79	81	177	190	220	29	55	B	822

Introduction

Special Features

Motor Selection
and PricingOptions Selection
and PricingTypical
Performance DetailsGeneral
Dimensions

MV449 Frame

Indexes



Typical Performance Details

LP100 (Continued)

SIMOTICS Definite Purpose – 60Hz LP100 NEMA Premium Solid Shaft Vertical Motors																									
HP	FL RPM	Frame	Current (A)									KVA/HP Code	Nominal Efficiency (%)			Power Factor			Torque			Locked Rotor Stall Time		NEMA Design	Approx. Weight (LBS)
			No Load			Full Load			Locked Rotor				1/2 Load (%)	3/4 Load (%)	Full Load (%)	1/2 Load (%)	3/4 Load (%)	Full Load (%)	Full Load Lb-FT	Locked Rotor TA/TN (%)	Break Down Tk/TN (%)	Hot (sec)	Cold (sec)		
			230V	460V	575V	230V	460V	575V	230V	460V	575V														
50	3535	326LP	30	15	12	110	55	44	726	363	290.4	G	93.8	94.1	93.6	82	89	91	74	150	250	18	37	B	799
50	1780	326LP	38	19	15.2	116	58	46.4	726	363	290.4	G	94.8	95	94.5	74	82	85	148	170	230	22	45	B	957
50	1185	365LP	48	24	19.2	124	62	49.6	726	363	290.4	G	94	94.3	94.1	67	76	80	222	190	220	29	55	B	855
60	3565	364LP	38	19	15.2	136	68	54.4	870	435	348	G	93.8	94.1	93.6	80	86	88	89	160	250	16	28	B	836
60	1780	364LP	38	19	15.2	136	68	54.4	870	435	348	G	95.2	95.4	95	77	85	87	177	180	240	26	38	B	885
60	1185	404LP	56	28	22.4	148	74	59.2	870	435	348	G	94.2	94.7	94.5	65	76	80	266	180	220	25	50	B	1021
75	3565	365LP	44	22	17.6	172	86	68.8	1086	543	434.4	G	93.7	94.3	94.1	81	86	88	111	160	260	16	27	B	877
75	1780	365LP	50	25	20	170	85	68	1086	543	434.4	G	95.6	95.8	95.4	78	85	87	221	180	240	25	35	B	948
75	1185	405LP	68	34	27.2	186	93	74.4	1086	543	434.4	G	94.7	94.9	94.5	68	77	80	332	180	220	33	45	B	1088
100	3570	405LP	38	19	15.2	216	108	86.4	1450	725	580	G	94.6	94.7	94.1	90	92	92	147	120	200	25	45	B	1057
100	1780	405LP	60	30	24	226	113	90.4	1450	725	580	G	95.8	96	95.4	80	86	87	295	180	200	25	35	B	1059
100	1185	444LP	78	39	31.2	234	117	93.6	1450	725	580	G	95.1	95.3	95	73	81	84	443	160	200	30	35	B	1385
125	1785	444LP	90	45	36	286	143	114.4	1816	908	726.4	G	95.4	95.6	95.4	78	84	86	368	160	200	20	25	B	1429
125	1185	445LP	96	48	38.4	288	144	115.2	1816	908	726.4	G	95.1	95.4	95	74	82	85	554	160	200	25	35	B	1565
150	1785	445LP	104	52	41.6	340	170	136	2170	1085	868	G	95.7	96	95.8	78	84	86	441	150	200	20	30	B	1565
150	1190	447LP	118	59	47.2	344	172	137.6	2170	1085	868	G	95.6	96	95.8	73	82	85	662	140	200	28	43	B	1778
200	1785	447LP	140	70	56	452	226	180.8	2900	1450	1160	G	96.2	96.5	96.2	76	84	86	588	160	200	18	25	B	1843
200	1190	449LP	146	73	58.4	454	227	181.6	2900	1450	1160	G	95.6	96.2	95.8	75	83	86	883	125	200	25	32	B	2204
250	1785	449LP	180	90	72	556	278	222.4	4200	2100	1680	H	96.1	96.3	96.2	78	85	87	735	140	200	18	25	A	2203
250	1190	449LP	172	86	68.8	562	281	224.8	4100	2050	1640	H	95.7	96	95.8	81	86	87	1104	120	200	20	25	A	2191



Typical Performance Details

HP100

SIMOTICS Definite Purpose – 60Hz
 HP100
 NEMA Premium
 Vertical Solid Shaft Motors

HP	FL RPM	Frame	Current (A)									KVA/HP Code	Nominal Efficiency (%)			Power Factor			Torque			Locked Rotor Stall Time		NEMA Design	Approx. Weight (LBS)
			No Load			Full Load			Locked Rotor				1/2 Load (%)	3/4 Load (%)	Full Load (%)	1/2 Load (%)	3/4 Load (%)	Full Load (%)	Full Load Lb-FT	Locked Rotor TA/TN (%)	Break Down Tk/TN (%)	Hot (sec)	Cold (sec)		
			230V	460V	575V	230V	460V	575V	230V	460V	575V														
3	3520	182HP	3.4	1.7	1.36	7.6	3.8	3.04	60	30	24	J	84.17	86.3	86.5	69.5	79.8	85.5	4.4	185	380	20	30	B	118
3	1760	182HP	4.2	2.1	1.68	8	4	3.2	66	33	26.4	K	87.8	89.4	89.5	59.5	71.7	78.5	9	235	360	17	29	B	129
3	1175	213HP	5	2.5	2	8.6	4.3	3.44	64	32	25.6	K	87.8	89.3	89.5	52.1	65.4	73	13.4	265	470	23	35	B	192
5	3505	184HP	4	2	1.6	12	6	4.8	92	46	36.8	J	88.2	89.1	88.5	78.1	85.9	88.2	7.5	170	420	15	29	B	130
5	1755	184HP	6	3	2.4	13	6.5	5.2	92	46	36.8	J	89.2	90	89.5	63.6	75.1	80.5	15	220	350	14	29	B	135
5	1165	215HP	7	3.5	3.6	13.4	6.7	5.36	92	46	36.8	J	89.5	90.1	89.5	59.4	71.4	78.1	26.5	220	380	14	21	B	204
7.5	3520	213HP	6	3	2.4	17.6	8.8	7.04	126	63	50.4	H	89.6	90.1	89.5	78.5	86.8	89.2	11	180	490	17	30	B	188
7.5	1765	213HP	10	5	4	19.4	9.7	7.76	126	63	50.4	H	90.73	91.7	91.7	60.5	72.3	78.9	22	270	450	25	42	B	211
7.5	1175	254HP	10	5	4	20	10	8	126	63	50.4	H	91.1	91.5	91	58.4	70.2	77.2	33	165	260	26	45	B	294
10	3515	215HP	7	3.5	2.8	23	11.5	9.2	162	81	64.8	H	91	91.1	90.2	81.5	88.8	90.3	15	180	440	14	28	B	202
10	1755	215HP	12.2	6.1	4.88	25	12.5	10	162	81	64.8	H	91.7	92.2	91.7	63.8	76.2	81.7	30	270	410	20	36	B	220
10	1175	256HP	12.6	6.3	5.04	27	13.5	10.8	162	81	64.8	H	91.4	91.6	91	61	71.6	76.2	45	165	250	18	38	B	310
15	3530	254HP	10.2	5.1	4.08	35	17.5	14	232	116	92.8	G	90.7	91.3	91	80.6	87.4	88.2	22	210	260	24	48	B	309
15	1770	254HP	17	8.5	6.8	38	19	15.2	232	116	92.8	G	92.3	92.8	92.4	64.5	74.7	80	44	185	235	21	33	B	315
15	1180	284HP	22	11	8.8	42	21	16.8	232	116	92.8	G	90.9	91.8	91.7	53	66	73	67	150	240	22	48	B	494
20	3515	256HP	10.4	5.2	4.16	45	22.5	18	290	145	116	G	92.1	91.6	91	86.2	91.3	91.5	30	185	230	20	45	B	337
20	1770	256HP	21	10.5	8.4	50	25	20	290	145	116	G	93.1	93.4	93	65.3	75.9	80.5	60	185	240	15	33	B	342
20	1180	286HP	26	13	10.4	54	27	21.6	290	145	116	G	91.2	92	91.7	57	69	76	89	150	240	20	45	B	551
25	3525	284HP	16	8	6.4	58	29	23.2	366	183	146.4	G	92	92.2	91.7	80	85	88	37	160	250	16	30	B	454
25	1775	284HP	22	11	8.8	60	30	24	366	183	146.4	G	93.5	94	93.6	71	80	84	74	180	250	24	44	B	535
25	1185	324HP	28	14	11.2	66	33	26.4	366	183	146.4	G	92.7	93.2	93	62	72	76	111	170	240	28	54	B	773
30	3525	286HP	19	9.5	7.6	68	34	27.2	436	218	174.4	G	92	92.2	91.7	84	89	90	45	160	250	16	30	B	486
30	1775	286HP	24	12	9.6	70	35	28	436	218	174.4	G	93.9	94.1	93.6	73	82	85	89	180	250	24	44	B	544
30	1185	326HP	30	15	12	78	39	31.2	436	218	174.4	G	93.1	93.5	93	64	73	77	133	170	220	26	52	B	809
40	3535	324HP	24	12	9.6	90	45	36	580	290	232	G	94	94.1	93.6	80	87	89	60	150	250	22	45	B	674
40	1780	324HP	30	15	12	92	46	36.8	580	290	232	G	94.3	94.1	94.1	75	83	86	118	180	230	22	45	B	737
40	1185	364HP	36	18	14.4	98	49	39.2	580	290	232	G	94.4	94.1	94.1	70	79	81	177	190	220	29	55	B	802

Introduction

Special Features

Motor Selection and Pricing

Options Selection and Pricing

Typical Performance Details

General Dimensions

MV449 Frame

Indexes



Typical Performance Details

HP100 (Continued)

SIMOTICS Definite Purpose – 60Hz HP100 NEMA Premium Vertical Solid Shaft Motors																									
HP	FL RPM	Frame	Current (A)									KVA/HP Code	Nominal Efficiency (%)			Power Factor			Torque			Locked Rotor Stall Time		NEMA Design	Approx. Weight (LBS)
			No Load			Full Load			Locked Rotor				1/2 Load (%)	3/4 Load (%)	Full Load (%)	1/2 Load (%)	3/4 Load (%)	Full Load (%)	Full Load Lb-FT	Locked Rotor TA/TN (%)	Break Down Tk/TN (%)	Hot (sec)	Cold (sec)		
			230V	460V	575V	230V	460V	575V	230V	460V	575V														
50	3535	326HP	30	15	12	110	55	44	726	363	290.4	G	93.8	94.1	93.6	82	89	91	74	150	250	18	37	B	689
50	1780	326HP	38	19	15.2	116	58	46.4	726	363	290.4	G	94.8	95	94.5	74	82	85	148	170	230	22	45	B	846
50	1185	365HP	48	24	19.2	124	62	49.6	726	363	290.4	G	94	94.3	94.1	67	76	80	222	190	220	29	55	B	835
60	3565	364HP	38	19	15.2	136	68	54.4	870	435	348	G	93.8	94.1	93.6	80	86	88	89	160	250	16	28	B	817
60	1780	364HP	38	19	15.2	136	68	54.4	870	435	348	G	95.2	95.4	95	77	85	87	177	180	240	26	38	B	865
60	1185	404HP	56	28	22.4	148	74	59.2	870	435	348	G	94.2	94.7	94.5	65	76	80	266	180	220	25	50	B	1000
75	3565	365HP	44	22	17.6	172	86	68.8	1086	543	434.4	G	93.7	94.3	94.1	81	86	88	111	160	260	16	27	B	857
75	1780	365HP	50	25	20	170	85	68	1086	543	434.4	G	95.6	95.8	95.4	78	85	87	221	180	240	25	35	B	928
75	1185	405HP	68	34	27.2	186	93	74.4	1086	543	434.4	G	94.7	94.9	94.5	68	77	80	332	180	220	33	45	B	1068
100	3570	405HP	38	19	15.2	216	108	86.4	1450	725	580	G	94.6	94.7	94.1	90	92	92	147	120	200	25	45	B	1023
100	1780	405HP	60	30	24	226	113	90.4	1450	725	580	G	95.8	96	95.4	80	86	87	295	180	200	25	35	B	1073
100	1185	444HP	78	39	31.2	234	117	93.6	1450	725	580	G	95.1	95.3	95	73	81	84	443	160	200	30	35	B	1372
125	1785	444HP	90	45	36	286	143	114.4	1816	908	726.4	G	95.4	95.6	95.4	78	84	86	368	160	200	20	25	B	1419
125	1185	445HP	96	48	38.4	288	144	115.2	1816	908	726.4	G	95.1	95.4	95	74	82	85	554	160	200	25	35	B	1557
150	1785	445HP	104	52	41.6	340	170	136	2170	1085	868	G	95.7	96	95.8	78	84	86	441	150	200	20	30	B	1559
150	1190	447HP	118	59	47.2	344	172	137.6	2170	1085	868	G	95.6	96	95.8	73	82	85	662	140	200	28	43	B	1786
200	1785	447HP	140	70	56	452	226	180.8	2900	1450	1160	G	96.2	96.5	96.2	76	84	86	588	160	200	18	25	B	1854
200	1190	449HP	146	73	58.4	454	227	181.6	2900	1450	1160	G	95.6	96.2	95.8	75	83	86	883	125	200	25	32	B	2216
250	1785	449HP	180	90	72	556	278	222.4	4200	2100	1680	H	96.1	96.3	96.2	78	85	87	735	140	200	18	25	A	2246
250	1190	449HP	172	86	68.8	562	281	224.8	4100	2050	1640	H	95.7	96	95.8	81	86	87	1104	120	200	20	25	A	2203



Typical Performance Details

SD200, DP200

SIMOTICS Severe Duty / Definite Purpose – 60 DP200 NEMA Premium Horizontal Pump System Motors																						
HP	FL RPM	Frame	Current (A)						KVA/HP Code	Nominal Efficiency (%)			Power Factor			Torque			Locked Rotor Stall Time		NEMA Design	Approx. Weight (LBS)
			No Load		Full Load		Locked Rotor	1/2 Load (%)		3/4 Load (%)	Full Load (%)	1/2 Load (%)	3/4 Load (%)	Full Load (%)	Full Load Lb-FT	Locked Rotor T/MTN (%)	Break Down Tk/TN (%)	Hot (sec)	Cold (sec)			
			460V	575V	460V	575V	460V	575V														
350	1190	5010	140	112	410	328	2550	2040	G	96.6	96.6	96.2	74.3	81.5	84.1	1543	270	250	30	35	B	4387
400	3585	509S	85	70	430	345	2900	2320	G	96	96.4	96.5	85.1	89.6	90.8	585	190	230	23	28	B	4219
400	1790	509	140	112	460	368	2900	2320	G	96.2	96.7	96.5	76.3	81.8	84.4	1174.6	230	250	19	23	B	4105
400	1190	5011	160	128	470	376	2900	2320	G	96.6	96.6	96.2	74.3	81.5	84.1	1763.5	270	250	30	35	B	4529
450	3585	5010S	100	80	480	385	3250	2600	G	96	96.4	96.5	85.1	89.6	90.8	659.3	190	230	23	28	B	4357
450	1790	5010	150	120	515	412	3250	2600	G	96.4	96.7	96.5	76.7	82.7	84.8	1325.3	230	250	17	21	B	4302
450	1190	L5011	170	136	525	420	3250	2600	G	96.6	96.6	96.2	74.3	81.5	84.1	1984	270	250	30	35	B	5083
500	3585	5011S	105	84	535	430	3625	2900	G	96	96.4	96.5	85.1	89.6	90.8	732.5	190	230	19	24	B	4504
500	1790	5011	160	128	570	456	3625	2900	G	96.5	96.8	96.7	78.2	85.3	84.9	1469.2	230	250	18	22	B	4509
500	1190	5012	185	148	580	464	3625	2900	G	96.6	96.6	96.2	74.3	81.5	84.1	2204.4	270	250	30	35	B	5289
600	3585	5012S	145	115	650	520	4250	3400	G	96.3	96.8	96.7	80.6	87	89.1	877.7	190	230	17	22	NA	4936
600	1790	5012	190	152	686	548.8	4400	3520	G	96.6	96.9	96.7	77.5	83.6	84.7	1767.6	230	250	19	23	NA	4993
600	1190	5013	245	196	695	556	4518	3614	G	96.6	96.6	96.2	74.3	81.5	84.1	2644.9	270	250	30	35	NA	5391
700	3585	5013S	160	128	750	600	5285	4228	G	94.8	95.6	95.8	86.5	90.4	91.1	1025.5	250	290	23	28	NA	5538
700	1790	5013	305	244	830	664	5395	4316	G	97.3	97.2	96.7	81.2	85.7	81.7	2056.3	230	250	18	22	NA	5592
800	3585	5013S	210	170	870	680	6300	5040	G	95.1	96	96.2	82.4	87.7	89.4	1172	250	290	19	24	NA	5798
800	1790	5013	335	268	920	736	5980	4784	G	97.4	97.2	96.7	80.9	85.6	84.2	2349.9	230	250	17	21	NA	5840
900	3585	5013S	225	180	980	785	7100	5700	G	95.1	96	96.2	82.4	87.7	89.4	1320	250	290	17	22	NA	6098

Introduction

Special Features

Motor Selection and Pricing

Options Selection and Pricing

Typical Performance Details

General Dimensions

MV449 Frame

Indexes



Typical Performance Details

SD10 MS

SIMOTICS Definite Purpose SD10 Energy Efficient Multi Speed Motors																	
HP	FL RPM	Frame	Current (A)			KVA/ HP Code	Nominal Efficiency (%)			Power Factor			Torque			Locked Rotor Stall Time	
			No Load	Full Load	Locked Rotor		1/2 Load (%)	3/4 Load (%)	Full Load (%)	1/2 Load (%)	3/4 Load (%)	Full Load (%)	Full Load Lb-FT	Locked Rotor T/FTN (%)	Break Down Tk/FTN (%)	Hot (sec)	Cold (sec)
			460V	460V	460V												
1/0.25	1763/876	143T	1.1/0.7	1.6/8	15.6/3.8	K	70.0/48.2	79.0/57.4	81.0/64.5	49/33	62/41	71/48	2.9/1.5	420/340	480/380	30	40
1.5/0.37	1755/870	145T	1.5/0.9	2.3/1.1	20.9/5.2	K	76/53	80/61	81.3/65.5	52/33	66/42	73/49	4.5/2.4	390/340	430/360	30	40
2/0.5	1775/880	182T	2.2/1.3	3.4/1.5	25.0/10.0	K	84.5/68.0	86.0/72.0	86.5/74.0	55/48	68/62	75/69	5.9/3.0	230/150	260/210	30	40
3/0.75	1765/875	184T	2.6/1.5	4.4/1.9	32.0/12.5	J	85.7/71.7	87.7/76.7	87.5/78.5	54/46	67/60	75/68	8.9/4.5	240/150	280/200	30	40
5/1.2	1760/865	213T	5.0/2.4	7.7/3.0	47.0/9.5	J	83.4/58.5	85.1/65.1	86.5/75.5	50/30	62.3/39.0	72/50	14.9/7.2	230/130	330/200	30	40
7.5/1.9	1755/875	215T	4.1/2.6	9.6/3.7	63.5/13.8	J	88.1/71	88.9/74.4	87.5/78.5	61/38	76.0/50.2	83/56	22.7/11.2	210/130	380/330	30	40
10/2.5	1765/880	254T	5.1/3.5	12.5/4.8	67.9/16.5	H	89.7/72.7	89.4/76.9	90.4/85.8	64/39	79.9/51.8	84/56	29.6/14.9	180/150	260/210	30	40
15/3.7	1765/880	256T	6.9/4.5	18.0/7.0	116.0/64.0	J	88.3/79.0	90.4/84.5	90.2/86.5	50/40	65/50	83/56	44.0/22.0	180/160	200/180	30	60
20/5	1770/880	284T	10/7.2	25/9.3	153/37	G	88.7/80	89/83	88.5/84	71/38	51/50	85/59	59.4/30	190/180	270/250	19	40
25/6.2	1765/880	286T	10.5/8	30/11.5	177/46	G	90.3/82.9	90.4/85.2	89.5/85.5	76/40	84/52	87/60	74/37	190/150	240/200	19	40
30/7.5	1770/885	324T	11.5/8.5	35/13	240/554	H	91.9/85	92.3/87.7	91.7/88.5	85/44	77/56	88/61	89/45	220/150	270/200	20	40
40/10	1770/885	326T	16/11.2	46/17	340/81	H	92.7/85.8	92.9/88.4	92.4/88.5	73/41	83/53	88/61	124/59	200/150	260/220	20	40
50/12.5	1780/890	364T	20.5/15.5	58/22.5	425/97	H	93.3/86.4	93.5/88.8	93/89.5	73/38	83/50	86/58	147/74	180/130	240/200	22	42
60/15	1780/885	365T	26/18.5	93.3/86.2	458/103	G	93.3/86.2	93.5/81	93/88.5	73/39	81/51	85/59	178/89	160/125	240/200	22	45
75/19	1785/890	405T	26.5/20	86/32	568/120	G	90.5/85.8	92.6/88.1	93/88.5	79/45	84/56	86/63	220/112	160/140	250/190	23	42
100/25	1790/890	444TS	41.5/31	118/46	804/178	H	94/88.4	94.1/90.4	93.6/91	73/40	81/51	84/59	293/147	220/150	280/200	28	36
125/31	1790/890	445TS	46/39	158/57	1045/223	H	92.7/88.9	93.2/90.9	93/91.7	67/38	77/48	81/56	367/182	190/150	240/200	20	23
150/37.5	1785/890	447TS	64.5/45.5	176/68	1260/273	H	92.1/87.6	93.2/89.6	93.6/90.2	73/39	82/50	85/58	441/221	210/170	270/200	24	29



Simotics General Dimensions

GP100 140-320 Frame

Schematics

140-250 Frame Foot Mount

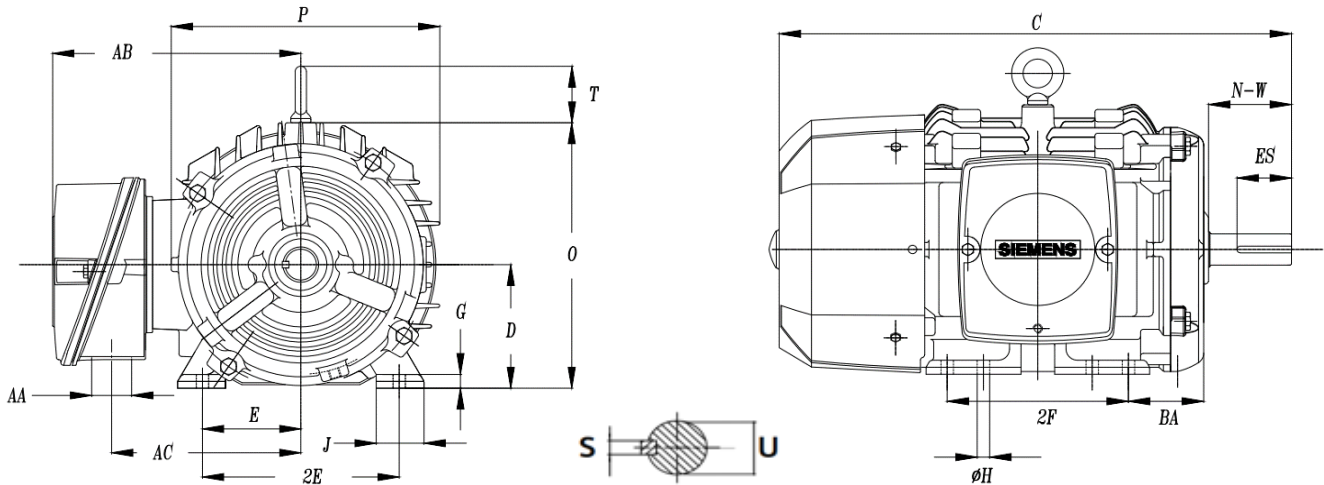

280-320 Frame Foot Mount

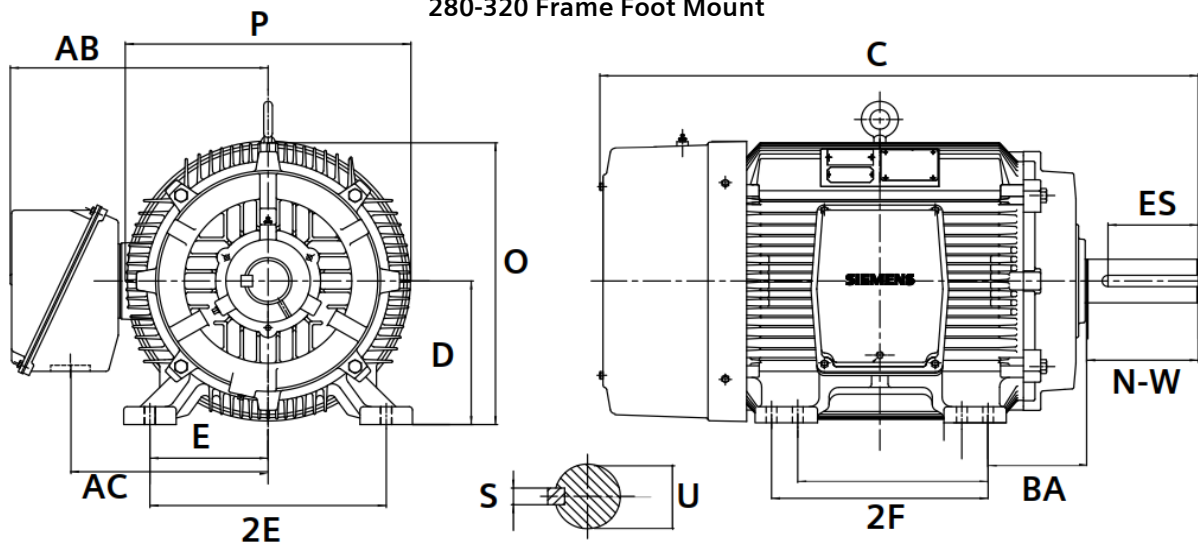

C-Face

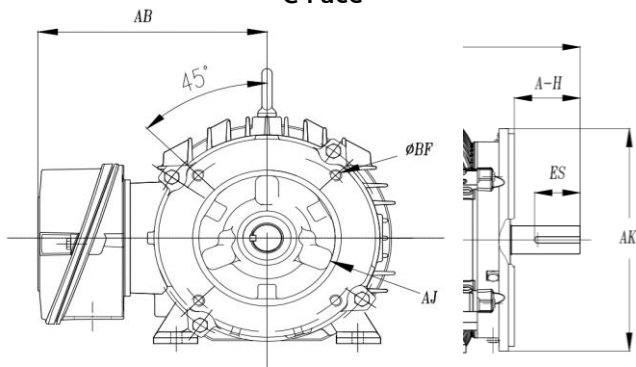

D-Flange

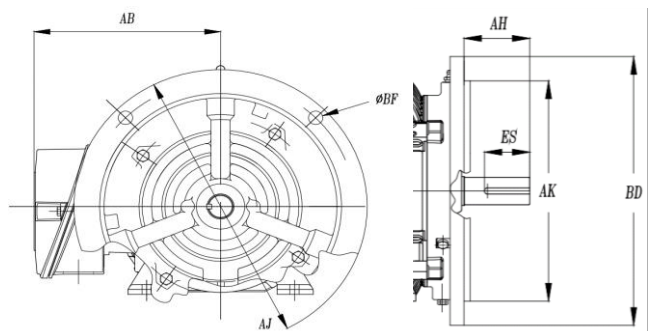

Dimension in Inches; Typical dimensions data, not guaranteed.
 Note: See Technical Notes for Drip Cover and Accessory Dimensions



Simotics General Dimensions

GP100 140-320 Frame

Details

Frame	Poles	C	2F	N-W	P	U	BA	AB	2E	D	O	Keyseat		
												R	S	ES
143/5T	All	13.44	4 / 5	2.25	7.98	0.875	2.25	6.9	5.5	3.5	7.55	0.771	0.188	1.41
182/4T	All	15.74	4.5/5.5	2.75	9.6	1.125	2.75	7.8	7.5	4.5	11.10	0.986	0.250	1.81
213/5T	All	19.15	5.5 / 7	3.38	11.19	1.375	3.5	9.25	8.5	5.25	10.66	1.201	0.312	2.44
254/6T	All	26.16	8.25/10	4	12.9	1.625	4.25	10.197	10.0	6.25	12.75	1.416	0.375	2.91
284T	All	29.38	9.50	4.63	15.8	1.875	4.75	13.63	11.0	7	14.87	1.59	0.500	3.25
286T	All	29.38	11.00	4.63	15.8	1.875	4.75	13.63	11.0	7	14.87	1.59	0.500	3.25
284TS	All	28.00	8.50	3.25	15.8	1.625	4.75	13.63	11.0	7	14.87	1.42	0.375	1.88
286TS	All	28.00	11.00	3.25	15.8	1.625	4.75	13.63	11.0	7	14.87	1.42	0.375	1.88
324T	All	32.07	10.50	5.25	17.7	2.125	5.25	14.14	12.5	8	16.66	1.85	0.500	3.88
326T	All	32.07	12.00	5.25	17.7	2.125	5.25	14.14	12.5	8	16.66	1.85	0.500	3.88
324TS	All	30.57	10.50	3.75	17.7	1.875	5.25	14.14	12.5	8	16.66	1.59	0.500	2
326TS	All	30.57	12.00	3.75	17.7	1.875	5.25	14.14	12.5	8	16.66	1.59	0.500	2

Frame	Pole	C-Face						
		BA*	AH	AJ	AK	BD	BF #	BF
143/5TC	All	2.25	2.12	5.875	4.5	6.60*	4	3/8-16" NC
182/4TC	All	2.75	2.62	7.25	8.5	8.90	4	1/2-13" NC
213/5TC	All	3.5	3.12	7.25	8.9	8.90	4	1/2-13" NC
254/6TC	All	4.25	3.75	7.25	8.5	9.30	4	1/2-13" NC
284/6TC	All	4.75	4.38	9.00	10.5	11.25	4	1/2-13" NC
284/6TSC	All	4.75	3	9.00	10.5	11.25	4	1/2-13" NC
324/6TC	All	5.25	5	11.00	12.5	14.00	4	5/8-11" NC
324/6TSC	All	5.25	3.5	11.00	12.5	14.00	4	5/8-11" NC

Frame	Poles	D-Flange						
		BA*	AH	AJ	AK	BD	BF #	BF
143/5TD	All	2.25	2.25	10.0	9.0	10.90	4	0.53
182/4TD	All	2.75	2.75	10.0	9.0	11.00	4	0.53
213/5TD	All	3.50	3.38	10.0	9.0	10.90	4	0.53
254/6TD	All	4.25	4.00	12.5	11.0	13.90	4	0.81
284/6TD	All	4.75	4.62	12.5	11.0	14.00	4	0.81
284/6TSD	All	4.75	3.25	12.5	11.0	14.00	4	0.81
324/6TD	All	5.25	5.25	16	14.0	18.00	4	0.81
324/6TSD	All	5.25	3.75	16	14.0	18.00	4	0.81

Dimension in Inches; Typical dimensions data, not guaranteed.
 Note: See Technical Notes for Drip Cover and Accessory Dimensions



Simotics General Dimensions

GP100 360-440 Frame

Schematics

360-440 Frame Foot Mount

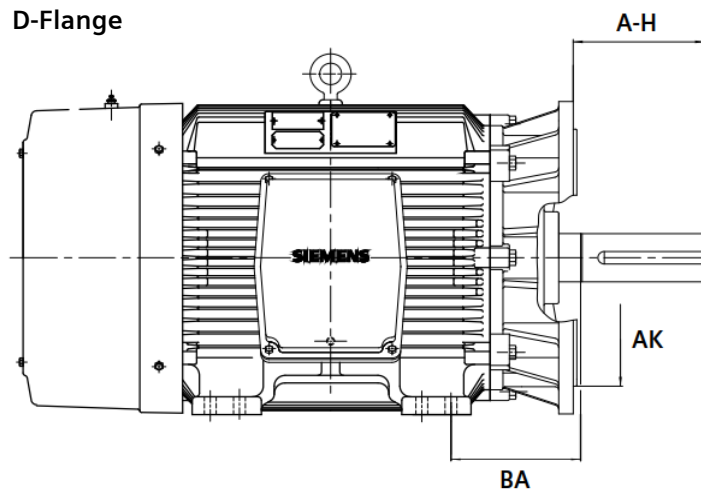
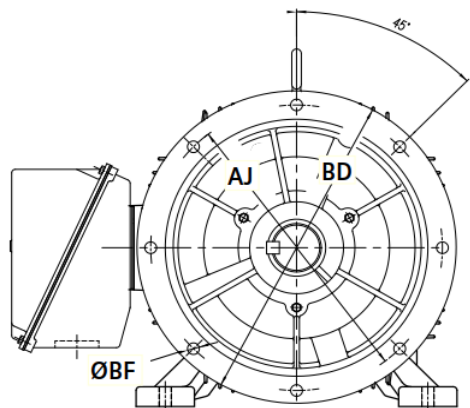
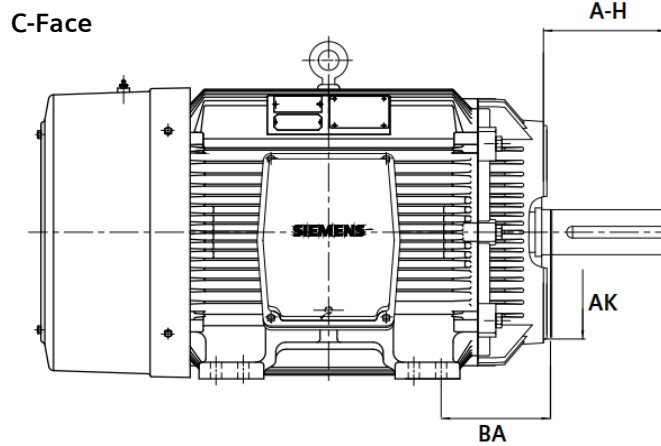
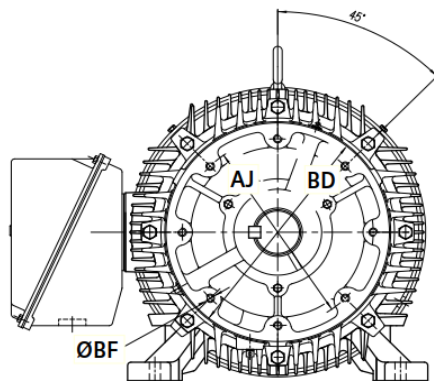
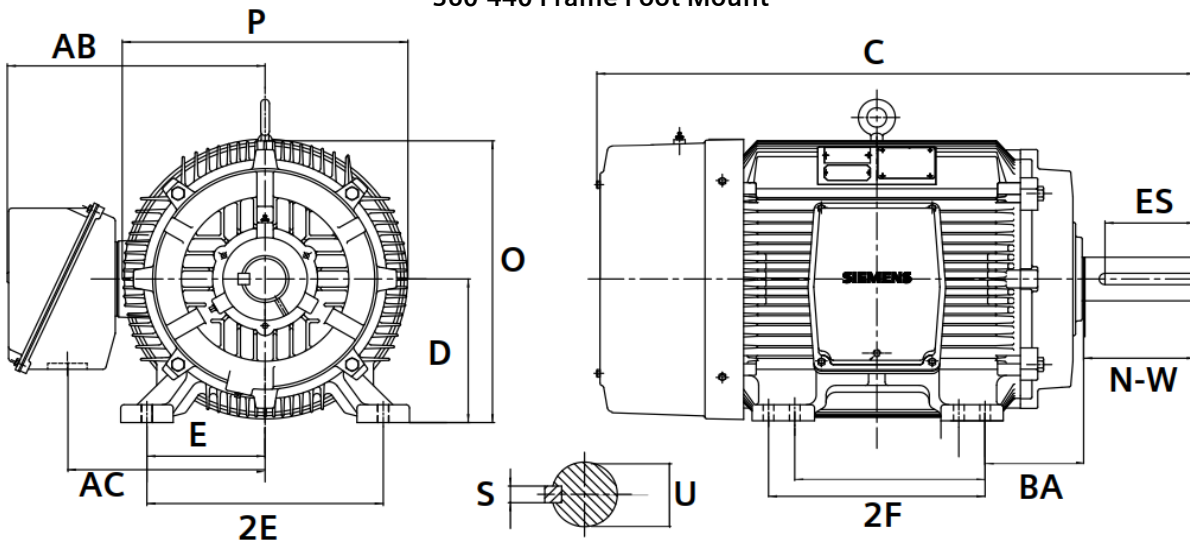

Dimension in Inches; Typical dimensions data, not guaranteed.
 Note: See Technical Notes for Drip Cover and Accessory Dimensions



Simotics General Dimensions

GP100 360-440 Frame

Details

Frame	Poles	C	2F	N-W	P	U	BA	AB	2E	D	O	Keyseat		
												R	S	ES
364T	All	35.53	11.25	5.88	19.6	2.375	5.88	17.56	14.0	9	18.48	2.02	0.625	4.25
265T	All	35.53	12.3	5.88	19.6	2.375	5.88	17.56	14.0	9	18.48	2.02	0.625	4.25
364TS	All	33.40	11.3	3.75	19.6	1.875	5.88	17.56	14.0	9	18.48	1.59	0.500	2
365TS	All	33.40	12.25	3.75	19.6	1.875	5.88	17.56	14.0	9	18.48	1.59	0.500	2
404T	All	39.50	12.25	7.25	19.6	2.875	6.62	17.68	16.0	10	19.60	2.45	0.750	5.63
405T	All	39.50	13.75	7.25	19.6	2.875	6.62	17.68	16.0	10	19.60	2.45	0.750	5.63
404TS	All	36.50	12.25	4.25	19.6	2.125	6.62	17.68	16.0	10	19.60	1.85	0.500	2.75
405TS	All	36.50	13.75	4.25	19.6	2.125	6.62	17.68	16.0	10	19.60	1.85	0.500	2.75
444T	All	45.60	14.50	8.5	21.8	3.375	7.5	18.88	18.0	11	21.80	2.88	0.875	6.88
445TS	All	45.60	16.50	8.5	21.8	3.375	7.5	18.88	18.0	11	21.80	2.88	0.875	6.88
444TS	All	41.80	14.50	4.75	21.8	2.375	7.5	18.88	18.0	11	21.80	2.02	0.625	3
445TS	All	41.80	16.50	4.75	21.8	2.375	7.5	18.88	18.0	11	21.80	2.02	0.625	3
447T	All	49.10	20.00	8.5	21.8	3.375	7.5	18.88	18.0	11	21.80	2.88	0.875	6.88
447TS	All	45.40	20.00	4.75	21.8	2.375	7.5	18.88	18.0	11	21.80	2.02	0.625	3
449T	All	54.10	25.00	8.5	21.8	3.375	7.5	18.88	18.0	11	21.80	2.88	0.875	6.88
449TS	All	50.30	25.00	4.75	21.8	2.375	7.5	18.88	18.0	11	21.80	2.02	0.625	3

Frame	Pole	C-Face						
		BA*	AH	AJ	AK	BD	BF #	BF
364/5TC	All	5.88	5.63	11	12.5	14	8	5/8-11" NC
364/5TSC	All	5.88	3.5	11.00	12.5	14.00	8	5/8-11" NC
404/5TC	All	6.62	7	11.00	12.5	15.50	8	5/8-11" NC
404/5TSC	All	6.62	4	11.00	12.5	15.50	8	5/8-11" NC
444TC	All	7.5	8.25	14.00	16	18.00	8	5/8-11" NC
445TSC	All	7.5	8.25	14.00	16	18.00	8	5/8-11" NC
444TSC	All	7.5	4.5	14.00	16	18.00	8	5/8-11" NC
445TSC	All	7.5	4.5	14.00	16	18.00	8	5/8-11" NC
447TC	All	7.5	8.25	14.00	16	18.00	8	5/8-11" NC
447TSC	All	7.5	4.5	14.00	16	18.00	8	5/8-11" NC
449TC	All	7.5	8.25	14.00	16	18.00	8	5/8-11" NC
449TSC	All	7.5	4.5	14.00	16	18.00	8	5/8-11" NC

Frame	Poles	D-Flange						
		BA*	AH	AJ	AK	BD	BF #	BF
364/5TD	All	6.75	5.88	16.0	14.0	18.00	4	0.81
364/5TSD	All	6.75	3.75	16.0	14.0	18.00	4	0.81
404/5TD	All	7.12	7.25	20.0	18.0	22.00	8	0.81
404/5TSD	All	7.12	4.25	20	18.0	22.00	8	0.81
444TD	All	7.5	8.50	20	18.0	22.00	8	0.81
445TSD	All	7.5	8.50	20	18.0	22.00	8	0.81
444TSD	All	7.5	4.75	20	18.0	22.00	8	0.81
445TSD	All	7.5	4.75	20	18.0	22.00	8	0.81
447TD	All	7.5	8.50	20	18.0	22.00	8	0.81
447TSD	All	7.5	4.75	20	18.0	22.00	8	0.81
449TD	All	7.5	8.50	20	18.0	22.00	8	0.81
449TSD	All	7.5	4.75	20	18.0	22.00	8	0.81

Dimension in Inches; Typical dimensions data, not guaranteed.
 Note: See Technical Notes for Drip Cover and Accessory Dimensions



Simotics General Dimensions

SD100 140-320 Frame

Schematics

140-250 Frame Foot Mount

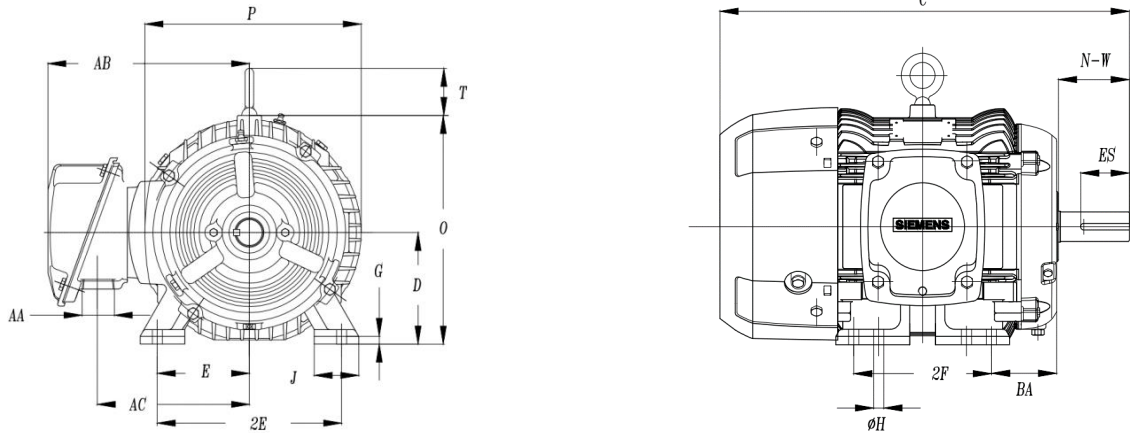

280-320 Frame Foot Mount

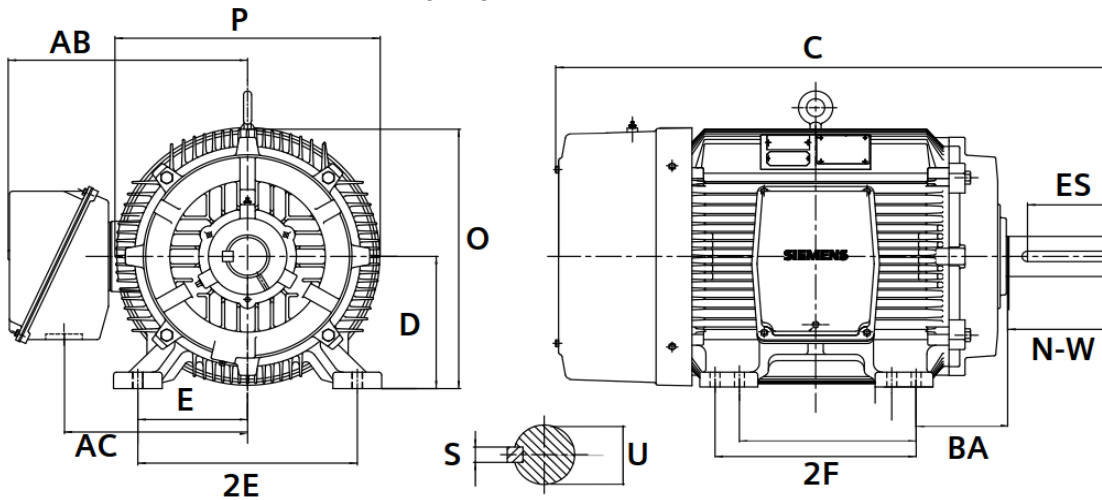

C-Face

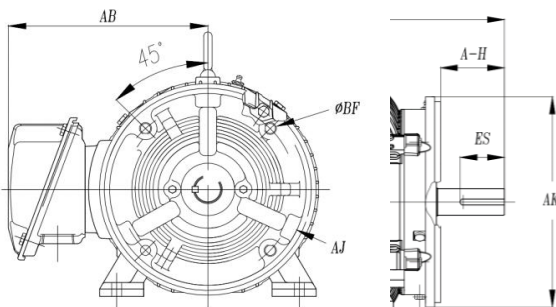

D-Flange

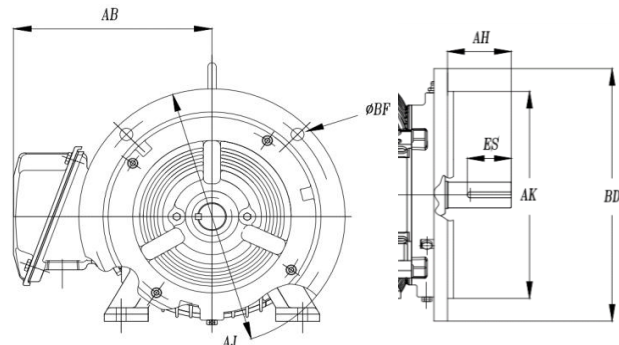

Dimension in Inches; Typical dimensions data, not guaranteed.
 Note: See Technical Notes for Drip Cover and Accessory Dimensions



Simotics General Dimensions

SD100 140-320 Frame

Details

Frame	Poles	C	2F	N-W	P	U	BA	AB	2E	D	O	Keyseat		
												R	S	ES
143T	All	14.20	4	2.25	8.2	0.875	2.25	7.4	5.5	3.5	7.50	0.771	0.188	1.41
145T	All	14.20	5.0	2.25	8.2	0.875	2.25	7.4	5.5	3.5	7.50	0.771	0.188	1.41
182T	All	16.40	4.5	2.75	9.6	1.125	2.75	8.2	7.5	4.5	11.10	0.986	0.250	1.81
184T	All	16.40	5.50	2.75	9.6	1.125	2.75	8.2	7.5	4.5	11.10	0.986	0.250	1.81
213T	All	20.20	5.50	3.38	10.7	1.375	3.5	10.39	8.5	5.25	10.66	1.201	0.312	2.44
215T	All	20.20	7.00	3.38	10.7	1.375	3.5	10.39	9.0	5.25	10.66	1.201	0.312	2.44
254T	All	25.80	8.25	4	12.9	1.625	4.25	11.14	10.0	6.25	12.75	1.416	0.375	2.91
256T	All	25.80	10.00	4	12.9	1.625	4.25	11.14	10.0	6.25	12.75	1.416	0.375	2.91
284T	All	29.40	9.50	4.63	15.8	1.875	4.75	14.3	11.0	7	14.87	1.519	0.500	3.25
286T	All	29.40	11.00	4.63	15.8	1.875	4.75	14.3	11.0	7	14.87	1.519	0.500	3.25
284TS	All	28.00	9.50	3.25	15.8	1.625	4.75	14.33	11.0	7	14.87	1.416	0.375	1.88
286TS	All	28.00	11.00	3.25	15.8	1.625	4.75	14.33	11.0	7	14.87	1.416	0.375	1.88
324T	All	32.10	10.50	5.25	17.7	2.125	5.25	15.99	12.5	12.5	16.66	1.845	0.500	3.88
326T	All	32.10	12.00	5.25	17.7	2.125	5.25	15.99	12.5	12.5	16.66	1.845	0.500	3.88
324TS	All	30.60	10.50	3.75	17.7	1.875	5.25	15.99	12.5	12.5	16.66	1.591	0.500	2
326TS	All	30.60	12.00	3.75	17.7	1.875	5.25	15.99	12.5	12.5	16.66	1.591	0.500	2

Frame	Pole	C-Face						
		BA*	AH	AJ	AK	BD	BF #	BF
143TC	All	2.25	2.12	5.875	4.5	6.5	4	3/8"-16 NC
145TC	All	2.25	2.12	5.88	4.5	6.50	4	3/8"-16 NC
182TC	All	2.75	2.62	7.25	8.5	9.00	4	1/2"-13 NC
184TC	All	2.75	2.62	7.25	8.5	9.00	4	1/2"-13 NC
213TC	All	3.5	3.12	7.25	8.5	9.00	4	1/2"-13 NC
215TC	All	3.5	3.12	7.25	8.5	9.00	4	1/2"-13 NC
254TC	All	4.25	3.75	7.25	8.5	10.00	4	1/2"-13 NC
256TC	All	4.25	3.75	7.25	8.5	10.00	4	1/2"-13 NC
284TC	All	4.75	4.38	9.00	10.5	11.25	4	1/2"-13 NC
286TC	All	4.75	4.38	9.00	10.5	11.25	4	1/2"-13 NC
284TSC	All	4.75	3	9.00	10.5	11.25	4	1/2"-13 NC
286TSC	All	4.75	3	9.00	10.5	11.25	4	1/2"-13 NC
324TC	All	5.25	5	11.00	12.5	14.00	4	5/8"-11 NC
326TC	All	5.25	5	11.00	12.5	14.00	4	5/8"-11 NC
324TSC	All	5.25	3.5	11.00	12.5	14.00	4	5/8"-11 NC
326TSC	All	5.25	3.5	11.00	12.5	14.00	4	5/8"-11 NC

Frame	Poles	D-Flange						
		BA*	AH	AJ	AK	BD	BF #	BF
143TD	All	2.25	2	10.0	9.0	11.00	4	0.53
145TD	All	2.25	2	10.0	9.0	11.00	4	0.53
182TD	All	2.75	2.5	10.0	9.0	11.00	4	0.53
184TD	All	2.75	2.50	10	9.0	11.00	4	0.53
213TD	All	3.5	3.13	10	9.0	11.00	4	0.53
215TD	All	3.5	3.13	10	9.0	11.00	4	0.53
254TD	All	4.25	3.75	12.5	11.0	14.00	4	0.53
256TD	All	4.25	3.75	12.5	11.0	14.00	4	0.53
284TD	4, 6	4.75	4.37	12.5	11.0	14.00	4	0.53
286TD	4, 6	4.75	4.37	12.5	11.0	14.00	4	0.53
284TSD	All	4.75	4.38	12.5	11.0	14.00	4	0.81
286TSD	All	4.75	3.00	12.5	11.0	14.00	4	0.81
324TD	All	5.25	5.00	16	14.0	18.00	4	0.81
326TD	All	5.25	5.00	16	14.0	18.00	4	0.81
324TSD	All	5.25	5.00	16	14.0	18.00	4	0.81
326TSD	All	5.25	3.50	16	14.0	18.00	4	0.81

Dimension in Inches; Typical dimensions data, not guaranteed.

Note: See Technical Notes for Drip Cover and Accessory Dimensions



Simotics General Dimensions

SD100 360-440 Frame

Schematics

360-440 Frame Foot Mount

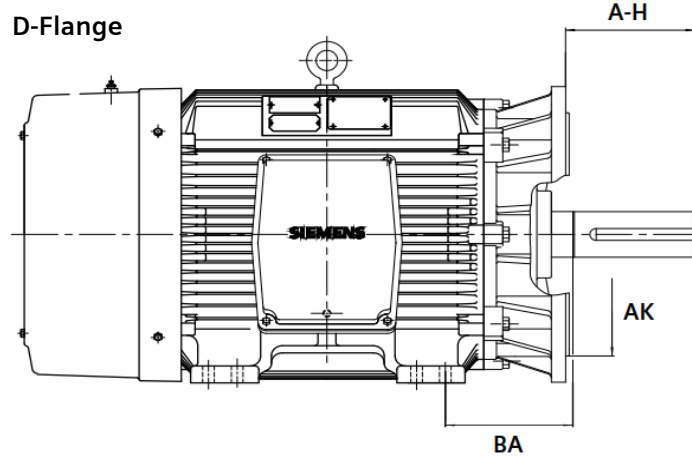
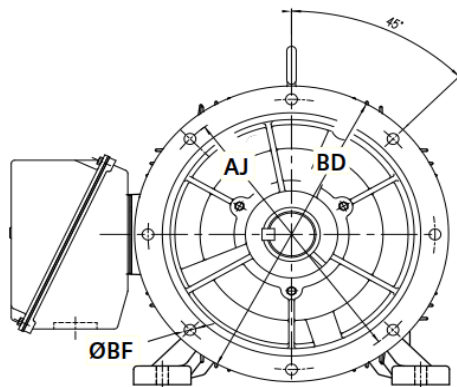
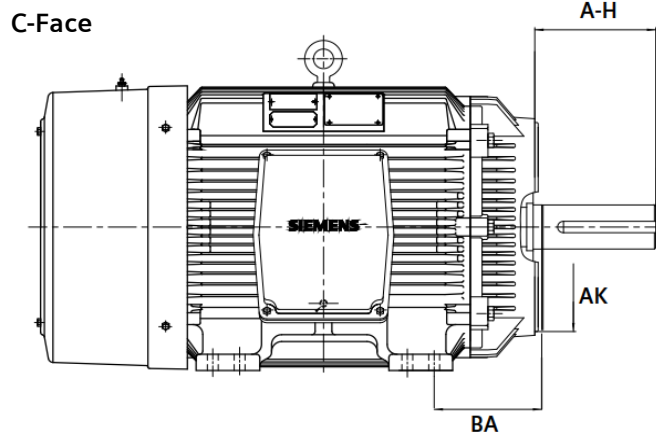
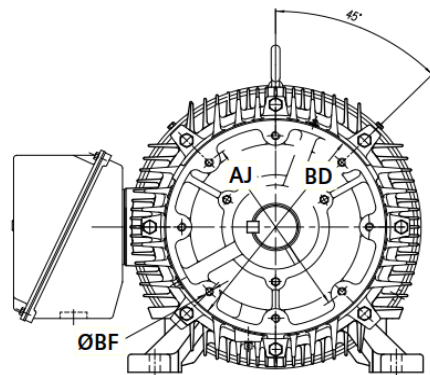
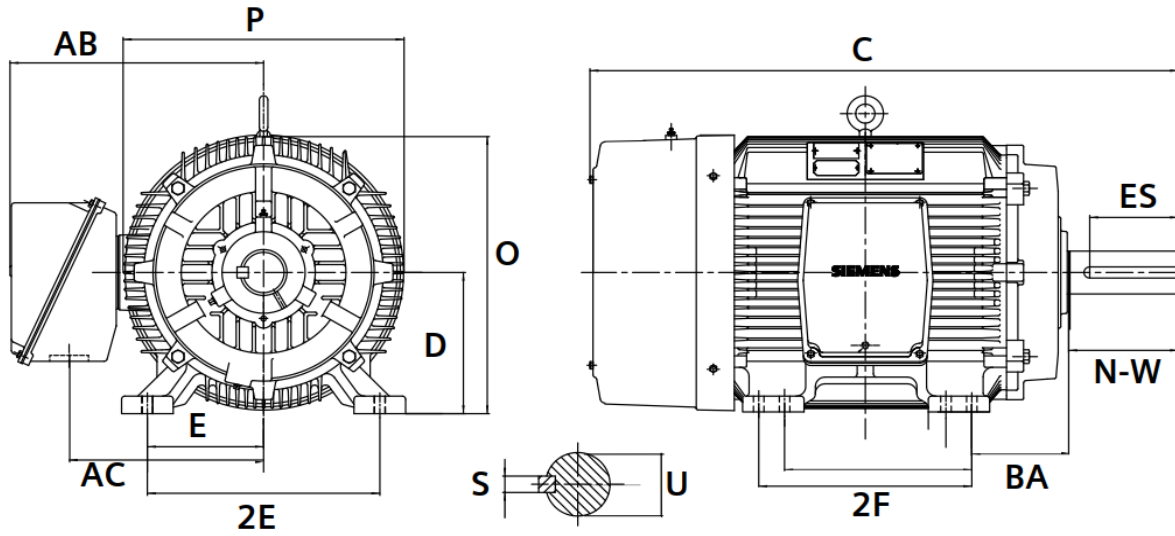

Dimension in Inches; Typical dimensions data, not guaranteed.
 Note: See Technical Notes for Drip Cover and Accessory Dimensions



Simotics General Dimensions

SD100 360-440 Frame

Details

Frame	Poles	C	2F	N-W	P	U	BA	AB	2E	D	O	Keyseat		
												R	S	ES
364T	All	35.50	11.25	5.88	19.6	2.375	5.88	18.57	14.0	9	18.48	2.021	0.625	4.25
365T	All	35.50	12.3	5.88	19.6	2.375	5.88	18.57	14.0	9	18.48	2.021	0.625	4.25
364TS	2	32.10	11.3	3.75	17.7	1.875	5.88	17.94	14.0	9	17.81	1.591	0.500	2
364TS	All	33.40	11.25	3.75	19.6	1.875	5.88	18.57	14.0	9	18.48	1.591	0.500	2
365TS	2	32.10	12.25	3.75	17.7	1.875	5.88	17.94	14.0	9	17.81	1.591	0.500	2
365TS	All	33.40	12.25	3.75	19.6	1.875	5.88	18.57	14.0	9	18.48	1.591	0.500	2
404T	All	39.40	12.25	7.25	19.6	2.875	6.62	18.38	16.0	10	19.60	2.45	0.750	5.63
405T	All	39.40	13.75	7.25	19.6	2.875	6.62	18.38	16.0	10	19.60	2.45	0.750	5.63
404TS	All	36.40	12.25	4.25	19.6	2.125	6.62	18.38	16.0	10	19.60	1.845	0.500	2.75
405TS	All	36.40	13.75	4.25	19.6	2.125	6.62	18.38	16.0	10	19.60	1.845	0.500	2.75
444T	All	45.60	14.50	8.5	21.8	3.375	7.5	19.63	18.0	11	21.80	2.88	0.875	6.88
445T	All	45.60	16.50	8.5	21.8	3.375	7.5	19.63	18.0	11	21.80	2.88	0.875	6.88
444TS	All	41.80	14.50	4.75	21.8	2.375	7.5	19.63	18.0	11	21.80	2.021	0.625	3.05
445TS	All	41.80	16.50	4.75	21.8	2.375	7.5	19.63	18.0	11	21.80	2.021	0.625	3.05
447T	All	49.00	20.00	8.5	21.8	3.375	7.5	19.63	18.0	11	22.00	2.88	0.875	6.88
447TS	All	45.30	20.00	4.75	21.8	2.375	7.5	19.63	18.0	11	22.00	2.021	0.625	3.05
449T	All	54.00	25.00	8.5	21.8	3.375	7.5	22	18.0	11	22.00	2.88	0.875	6.88
449TS	All	50.30	25.00	4.75	21.8	2.375	7.5	22	18.0	11	22.00	2.021	0.625	3.05
S449LS	All	63.60	25.00	9.12	24.6	3.625	7.5	23	18.0	11	23.30	3.134	0.875	7.5
S449SS	All	59.80	25.00	5.25	24.6	2.625	7.5	23	18.0	11	23.30	2.275	0.625	3.5
S449SS	2 ¹⁾	63.20	25.00	5.25	24.6	2.625	7.5	23	18.0	11	23.30	2.275	0.625	3.5

Frame	Pole	C-Face						
		BA*	AH	AJ	AK	BD	BF #	BF
364TC	All	5.88	5.63	11.00	12.5	12.75	8	5/8"-11 NC
365TC	All	5.88	5.63	11.00	12.5	12.75	8	5/8"-11 NC
364TSC	All	5.88	3.5	11.00	12.5	12.75	8	5/8"-11 NC
365TSC	All	5.88	3.5	11.00	12.5	12.75	8	5/8"-11 NC
404TC	All	6.62	7	11.00	12.5	15.50	8	5/8"-11 NC
405TC	All	6.62	7	11.00	12.5	15.50	8	5/8"-11 NC
404TSC	All	6.62	4	11.00	12.5	15.50	8	5/8"-11 NC
405TSC	All	6.62	4	11.00	12.5	15.50	8	5/8"-11 NC
444TC	All	7.5	8.25	14.00	16	18.00	8	5/8"-11 NC
445TC	All	7.5	8.25	14.00	16	18.00	8	5/8"-11 NC
444TSC	All	7.5	4.5	14.00	16	18.00	8	5/8"-11 NC
445TSC	All	7.5	4.5	14.00	16	18.00	8	5/8"-11 NC
447TC	All	7.5	8.25	14.00	16	18.00	8	5/8"-11 NC
447TSC	All	7.5	4.5	14.00	16	18.00	8	5/8"-11 NC
449TC	All	7.5	8.25	14.00	16	18.00	8	5/8"-11 NC
449TSC	All	7.5	4.5	14.00	16	18.00	8	5/8"-11 NC
S449LSC	All	7.5	8.25	14.00	16	18.00	8	5/8"-11 NC
S449SSC	All	7.5	4.5	14.00	16	18.00	8	5/8"-11 NC

Frame	Poles	D-Flange						
		BA*	AH	AJ	AK	BD	BF #	BF
364TD	All	5.88	5.63	16.0	14.0	18.00	4	0.81
365TD	All	5.88	5.63	16.0	14.0	18.00	4	0.81
364TSD	All	5.88	3.5	16.0	14.0	18.00	4	0.81
365TSD	All	5.88	3.50	16	14.0	18.00	4	0.81
404TD	All	6.62	7.00	20	18.0	22.00	4	0.81
405TD	All	6.62	7.00	20	18.0	22.00	4	0.81
405TSD	All	6.62	4.00	20	18.0	22.00	4	0.81
405TSD	All	6.62	4.00	20	18.0	22.00	4	0.81
444TD	All	7.5	8.50	20	18.0	22.00	8	0.81
445TD	All	7.5	8.50	20	18.0	22.00	8	0.81
444TSD	All	7.5	4.75	20	18.0	22.00	8	0.81
445TSD	All	7.5	4.75	20	18.0	22.00	8	0.81
447TD	All	7.5	8.50	20	18.0	22.00	8	0.81
447TSD	All	7.5	4.75	20	18.0	22.00	8	0.81
449TD	All	7.5	8.50	20	18.0	22.00	8	0.81
449TSD	All	7.5	4.75	20	18.0	22.00	8	0.81
S449LSD	All	7.5	8.50	20	18.0	22.00	8	0.81
S449SSD	All	7.5	4.75	20	18.0	22.00	8	0.81

Dimension in Inches; Typical dimensions data, not guaranteed.

Note: See Technical Notes for Drip Cover and Accessory Dimensions



Simotics General Dimensions

SD100 IEEE 140-320 Frame

Schematics

140-250 Frame Foot Mount

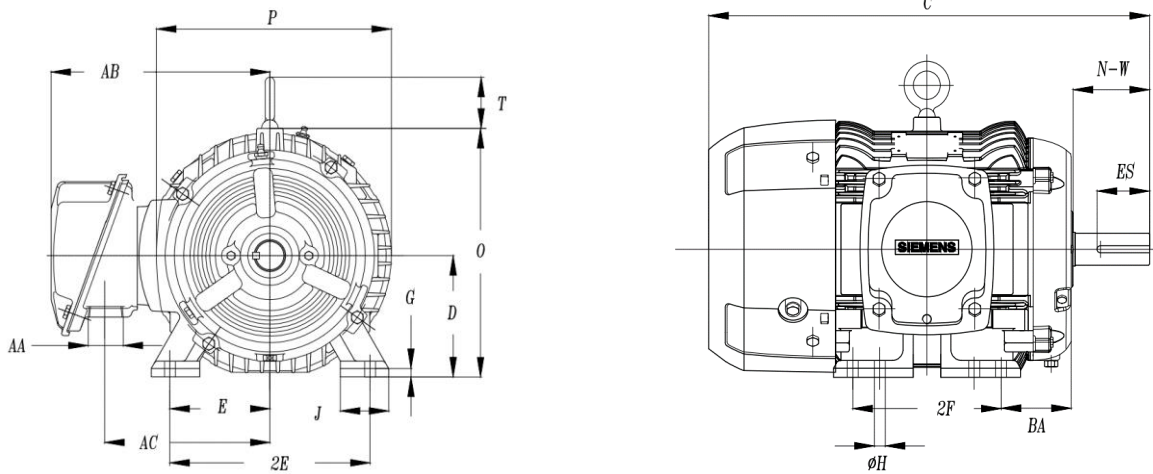

280-320 Frame Foot Mount

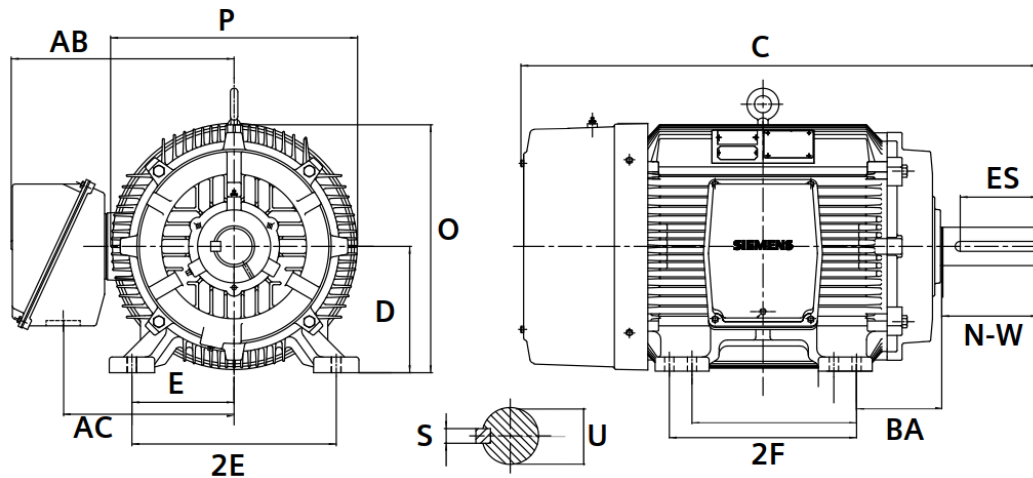

C-Face

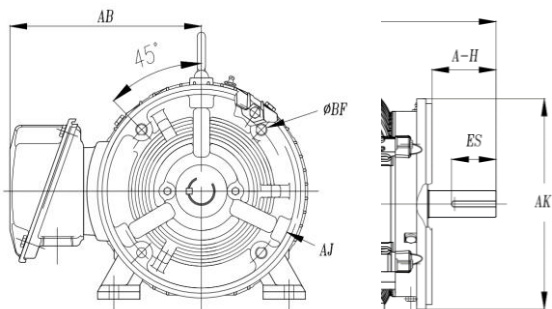

D-Flange

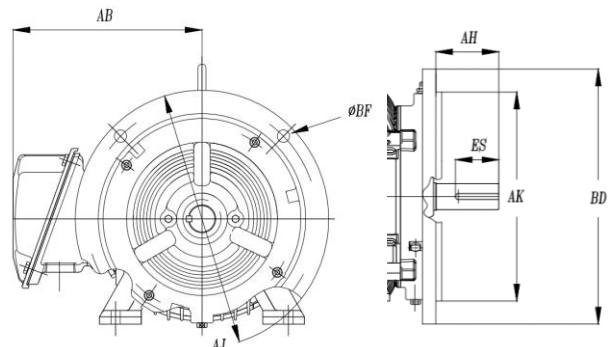

Dimension in Inches; Typical dimensions data, not guaranteed.
 Note: See Technical Notes for Drip Cover and Accessory Dimensions



Simotics General Dimensions

SD100 IEEE 140-320 Frame

Details

Frame	Poles	C	2F	N-W	P	U	BA	AB	2E	D	O	Keyseat		
												R	S	ES
143T	2, 4, 6, 8	14.00	4	1.77	8.1	0.875	2.73	7.05	5.5	3.5	7.42	0.771	0.188	1.41
145T	2, 4, 6, 8	14.00	5.0	1.77	8.1	0.875	2.73	7.05	5.5	3.5	7.42	0.771	0.188	1.41
182T	2, 8	14.80	4.5	2.46	9	1.125	3.03	8	7.5	4.5	9.00	0.986	0.250	1.78
182T	4, 6	16.20	4.50	2.46	10.8	1.125	3.03	8.58	7.5	4.5	9.74	0.986	0.250	1.78
184T	2, 8	15.90	5.50	2.46	9	1.125	3.03	8	7.5	4.5	9.00	0.986	0.250	1.78
184T	4, 6	16.20	5.50	2.46	10.8	1.125	3.03	8.58	7.5	4.5	9.74	0.986	0.250	1.78
213T	2, 8	18.20	5.50	2.88	10.6	1.375	4	9.4	8.5	5.25	10.43	1.201	0.312	2.41
213T	4, 6	20.30	5.50	2.85	12.2	1.375	4.03	10.63	8.5	5.25	11.35	1.201	0.312	2.41
215T	2, 8	19.70	7.00	2.88	10.6	1.375	4	9.4	8.5	5.25	10.43	1.201	0.313	2.41
215T	4, 6	20.30	7.00	2.85	12.2	1.375	4.03	10.63	8.5	5.25	11.35	1.201	0.312	2.41
254T	All	25.80	8.25	3.47	14.4	1.625	4.78	11.62	10.0	6.25	13.34	1.416	0.375	2.91
256T	All	25.80	10.00	3.47	14.4	1.625	4.78	11.62	10.0	6.25	13.34	1.416	0.375	2.91
284T	All	29.40	9.50	4.09	15.8	1.875	5.29	14.3	11.0	7	14.87	1.591	0.500	3.25
286T	All	29.40	11.00	4.09	15.8	1.875	5.29	14.3	11.0	7	14.87	1.591	0.500	3.25
284TS	All	28.00	9.50	2.72	15.8	1.625	5.28	14.33	11.0	7	14.87	1.416	0.375	1.88
286TS	All	28.00	11.00	2.72	15.8	1.625	5.28	14.33	11.0	7	14.87	1.416	0.375	1.88
324T	All	32.10	10.50	4.69	17.7	2.125	5.8	15.99	12.5	8	16.66	1.845	0.500	3.88
326T	All	32.10	12.00	4.69	17.7	2.125	5.8	15.99	12.5	8	16.66	1.845	0.500	3.88
324TS	All	30.60	10.50	3.25	17.7	1.875	5.75	15.99	12.5	8	16.66	1.591	0.500	2
326TS	All	30.60	12.00	3.25	17.7	1.875	5.75	15.99	12.5	8	16.66	1.591	0.500	2

Frame	Pole	C-Face						
		BA*	AH	AJ	AK	BD	BF #	BF
143TC	All	2.38	2.12	5.875	4.5	6.5	4	3/8"-16 NC
145TC	All	2.38	2.12	5.88	4.5	6.50	4	3/8"-16 NC
182TC	All	2.87	2.62	7.25	8.5	9.00	4	1/2"-13 NC
184TC	All	2.87	2.62	7.25	8.5	9.00	4	1/2"-13 NC
213TC	All	3.72	3.12	7.25	8.5	9.00	4	1/2"-13 NC
215TC	All	3.72	3.12	7.25	8.5	9.00	4	1/2"-13 NC
254TC	All	4.42	3.75	7.25	8.5	10.00	4	1/2"-13NC
256TC	All	4.42	3.75	7.25	8.5	10.00	4	1/2"-13NC
284TC	All	5.29	4.38	9.00	10.5	11.25	4	1/2"-13NC
286TC	All	5.29	4.38	9.00	10.5	11.25	4	1/2"-13NC
284TSC	All	5.29	3	9.00	10.5	11.25	4	1/2"-13NC
286TSC	All	5.29	3	9.00	10.5	11.25	4	1/2"-13NC
324TC	All	5.8	5	11.00	12.5	14.00	4	5/8"-11NC
326TC	All	5.8	5	11.00	12.5	14.00	4	5/8"-11NC
324TSC	All	5.75	3.5	11.00	12.5	14.00	4	5/8"-11NC
326TSC	All	5.75	3.5	11.00	12.5	14.00	4	5/8"-11NC

Frame	Poles	D-Flange						
		BA*	AH	AJ	AK	BD	BF #	BF
143TD	All	2.38	2.25	10.0	9.0	11.00	4	0.53
145TD	All	2.38	2.25	10.0	9.0	11.00	4	0.53
182TD	All	2.87	2.75	10.0	9.0	11.00	4	0.53
184TD	All	2.87	2.75	10	9.0	11.00	4	0.53
213TD	All	3.72	3.32	10	9.0	11.00	4	0.53
215TD	All	3.72	3.32	10	9.0	11.00	4	0.53
254TD	All	4.42	4.00	12.5	11.0	14.00	4	0.81
256TD	All	4.42	4.00	12.5	11.0	14.00	4	0.81
284TD	All	5.29	4.62	12.5	11.0	14.00	4	0.81
286TD	All	5.29	4.62	12.5	11.0	14.00	4	0.81
284TSD	All	5.29	3.25	12.5	11.0	14.00	4	0.81
286TSD	All	5.29	3.25	12.5	11.0	14.00	4	0.81
324TD	All	6.25	5.25	16	14.0	18.00	4	0.81
326TD	All	6.25	5.25	16	14.0	18.00	4	0.81
324TSD	All	6.25	3.75	16	14.0	18.00	4	0.81
326TSD	All	6.25	3.75	16	14.0	18.00	4	0.81

Dimension in Inches; Typical dimensions data, not guaranteed.
 Note: See Technical Notes for Drip Cover and Accessory Dimensions



Simotics General Dimensions

SD100 IEEE 360-440 Frame

Schematics

360-440 Frame Foot Mount

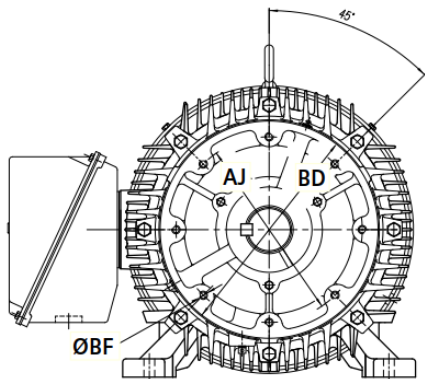
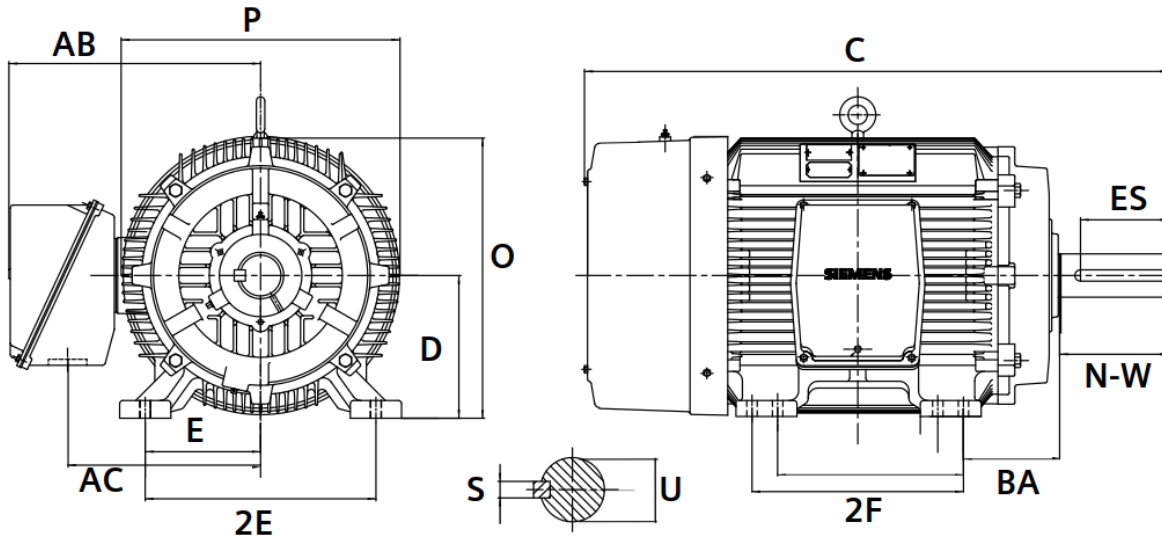

C-Face

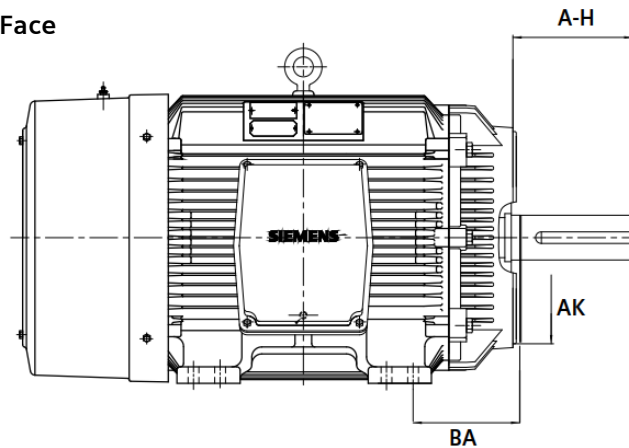

D-Flange

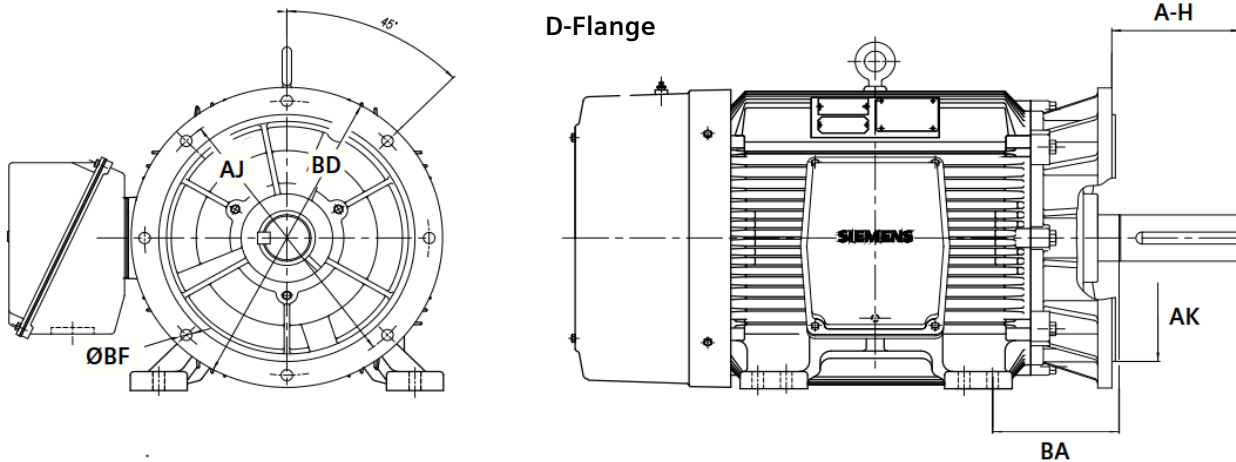

Dimension in Inches; Typical dimensions data, not guaranteed.
 Note: See Technical Notes for Drip Cover and Accessory Dimensions



Simotics General Dimensions

SD100 IEEE 360-440 Frame

Details

Frame	Poles	C	2F	N-W	P	U	BA	AB	2E	D	O	Keyseat		
												R	S	ES
364T	All	35.50	11.25	5.4	19.6	2.375	6.35	18.57	14.0	9	18.48	2.021	0.625	4.25
365T	All	35.50	12.3	5.4	19.6	2.375	6.35	18.57	14.0	9	18.48	2.021	0.625	4.25
364TS	All	33.40	11.3	3.28	19.6	1.875	6.35	18.57	14.0	9	18.48	1.591	0.500	2
365TS	All	33.40	12.25	3.28	19.6	1.875	6.35	18.57	14.0	9	18.48	1.591	0.500	2
365TS	2	32.10	12.25	3.75	17.7	1.875	5.88	17.94	14.0	9	17.81	1.591	0.500	2
365TS	All	33.40	12.25	3.75	19.6	1.875	5.88	18.57	14.0	9	18.48	1.591	0.500	2
404T	All	39.40	12.25	6.78	19.6	2.875	7.1	18.38	16.0	10	19.60	2.45	0.750	5.63
405T	All	39.40	13.75	6.78	19.6	2.875	7.1	18.38	16.0	10	19.60	2.45	0.750	5.63
404TS	All	36.40	12.25	3.5	19.6	2.125	7.38	18.38	16.0	10	19.60	1.845	0.500	2.75
405TS	All	36.40	13.75	3.5	19.6	2.125	7.38	18.38	16.0	10	19.60	1.845	0.500	2.75
444T	All	45.60	14.50	8.1	21.8	3.375	7.9	19.63	18.0	11	21.80	2.88	0.875	6.88
445T	All	45.60	16.50	8.1	21.8	3.375	7.9	19.63	18.0	11	21.80	2.88	0.875	6.88
444TS	All	41.80	14.50	4	21.8	2.375	8.25	19.63	18.0	11	21.80	2.021	0.625	3.05
445TS	All	41.80	16.50	4	21.8	2.375	8.25	19.63	18.0	11	21.80	2.021	0.625	3.05
447T	All	49.00	20.00	8.03	21.8	3.375	7.96	19.63	18.0	11	22.00	2.88	0.875	6.88
447TS	All	45.30	20.00	4	21.8	2.375	8.25	19.63	18.0	11	22.00	2.021	0.625	3.05
449T	All	54.00	25.00	8.03	21.8	3.375	7.96	22	18.0	11	22.00	2.88	0.875	6.88
449TS	All	50.30	25.00	4	21.8	2.375	8.25	22	18.0	11	22.00	2.021	0.625	3.05
S449LS	6, 8	63.60	25.00	8.67	24.6	3.625	7.95	23	18.0	11	23.30	3.134	0.875	7.5
S449LS	4	66.70	25.00	8.67	24.6	3.625	7.95	23	18.0	11	23.30	3.134	0.875	7.5
S449SS	6, 8	59.80	25.00	4.59	24.6	2.625	8.16	23	18.0	11	23.30	2.275	0.625	3.5
S449SS	2, 4	63.20	25.00	4.59	24.6	2.625	8.16	23	18.0	11	23.30	2.275	0.625	3.5

6	Pole	C-Face						
		BA*	AH	AJ	AK	BD	BF #	BF
364TC	All	6.35	5.63	11.00	12.5	12.75	8	5/8"-11NC
365TC	All	6.35	5.63	11.00	12.5	12.75	8	5/8"-11NC
364TSC	All	6.35	3.5	11.00	12.5	12.75	8	5/8"-11NC
365TSC	All	6.35	3.5	11.00	12.5	12.75	8	5/8"-11NC
404TC	All	7.1	7	11.00	12.5	15.50	8	5/8"-11NC
405TC	All	7.1	7	11.00	12.5	15.50	8	5/8"-11NC
404TSC	All	7.38	4	11.00	12.5	15.50	8	5/8"-11NC
405TSC	All	7.38	4	11.00	12.5	15.50	8	5/8"-11NC
444TC	All	7.9	8.25	14.00	16	18.00	8	5/8"-11NC
445TC	All	7.9	8.25	14.00	16	18.00	8	5/8"-11NC
444TSC	All	8.25	4.5	14.00	16	18.00	8	5/8"-11NC
445TSC	All	8.25	4.5	14.00	16	18.00	8	5/8"-11NC
447TC	All	7.96	8.25	14.00	16	18.00	8	5/8"-11NC
447TSC	All	8.25	4.5	14.00	16	18.00	8	5/8"-11NC
449TC	All	7.96	8.25	14.00	16	18.00	8	5/8"-11NC
449TSC	All	8.25	4.5	14.00	16	18.00	8	5/8"-11NC
S449LSC	All	7.95	8.25	14.00	16	18.00	8	5/8"-11NC
S449SSC	All	8.16	4.5	14.00	16	18.00	8	5/8"-11NC

Frame	Pole	D-Flange						
		BA*	AH	AJ	AK	BD	BF #	BF
364TD	All	6.75	5.88	16.0	14.0	18.00	4	0.81
365TD	All	6.75	5.88	16.0	14.0	18.00	4	0.81
364TSD	All	6.75	3.75	16.0	14.0	18.00	4	0.81
365TSD	All	6.75	3.75	16	14.0	18.00	4	0.81
404TD	All	7.07	7.25	20	18.0	22.00	8	0.81
405TD	All	7.07	7.25	20	18.0	22.00	8	0.81
404TSD	All	7.38	4.25	20	18.0	22.00	8	0.81
405TSD	All	7.38	4.25	20	18.0	22.00	8	0.81
444TD	All	8.38	8.50	20	18.0	22.00	8	0.81
445TD	All	8.38	8.50	20	18.0	22.00	8	0.81
444TSD	All	8.38	4.75	20	18.0	22.00	8	0.81
445TSD	All	8.38	4.75	20	18.0	22.00	8	0.81
447TD	All	8.38	8.50	20	18.0	22.00	8	0.81
447TSD	All	8.38	4.75	20	18.0	22.00	8	0.81
449TD	All	8.38	8.50	20	18.0	22.00	8	0.81
449TSD	All	8.38	4.75	20	18.0	22.00	8	0.81
S449LSD	All	7.95	7.95	20	18.0	22.00	8	0.81
S449SSD	All	8.16	8.16	20	18.0	22.00	8	66

Dimension in Inches; Typical dimensions data, not guaranteed.
 Note: See Technical Notes for Drip Cover and Accessory Dimensions



Introduction
 Special Features
 Motor Selection and Pricing
 Options Selection and Pricing
 Typical Performance Details
 General Dimensions
 MV449 Frame
 Indexes

Simotics General Dimensions

SD200/DP200 HPS

Schematics

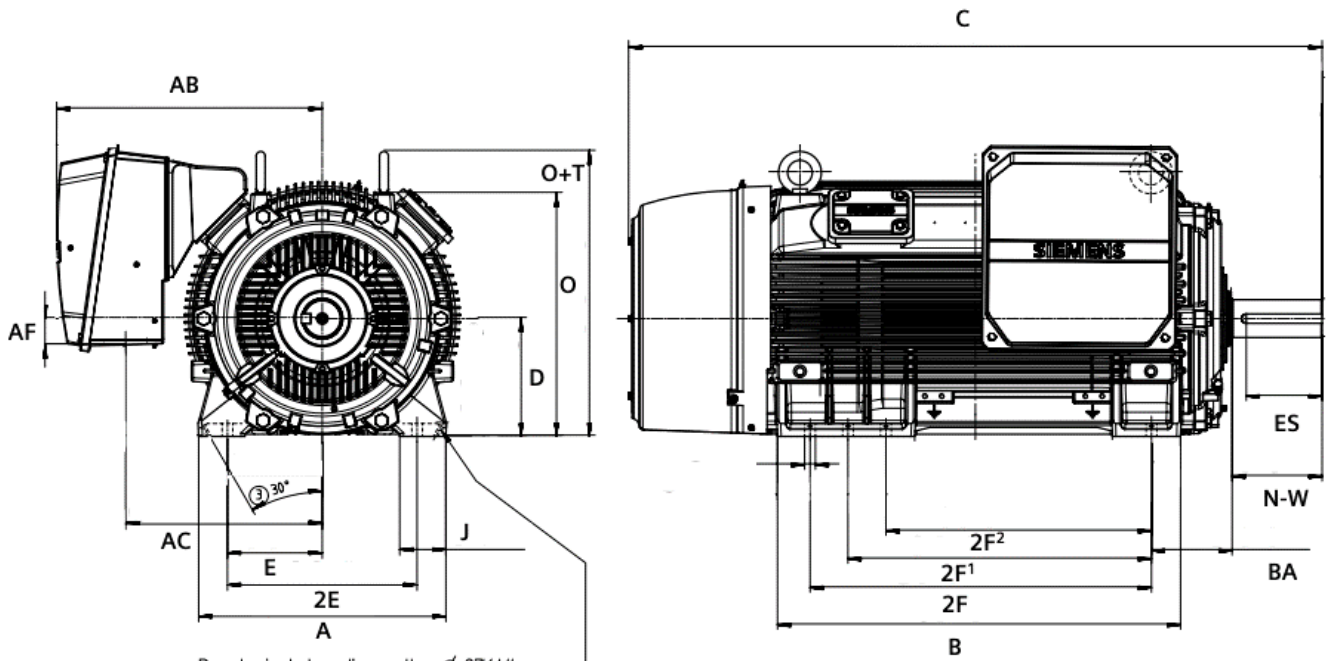

Dowel pin holes diagonally $\varnothing 27/64''$, one hole for each mounting hole.

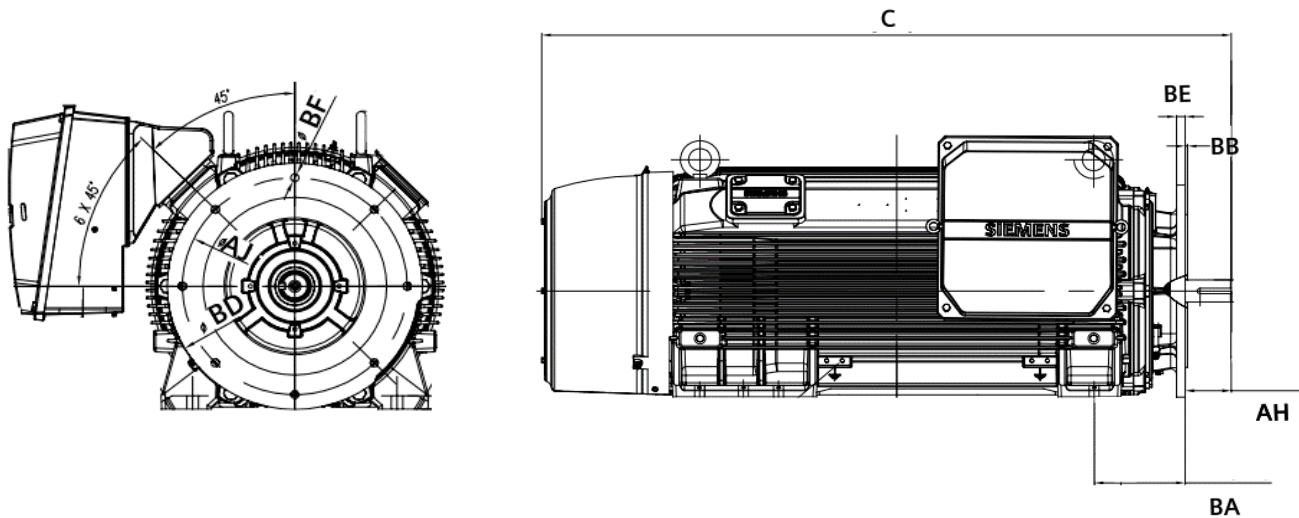
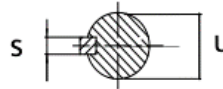

Dimension in Inches; Typical dimensions data, not guaranteed.
 Note: See Technical Notes for Drip Cover and Accessory Dimensions



Simotics General Dimensions

SD200/DP200 HPS

Details

Frames	A	2E	AC	AB	AF	O	D	C	2F	2F ¹	2F ²	B	BA	N-W	U	Keyseat		
																R	S	ES
509	26.1	20.00	20.70	28.00	2.80	25.7	12.5	73.1	--	--	28	42.5	8.5	9.50	4.00	3.4	1.000	8
5010	26.1	20.00	20.70	28.00	2.80	25.7	12.5	73.1	--	32	--	42.5	8.5	9.50	4.00	3.4	1.000	8
5011	26.1	20.00	20.70	28.00	2.80	25.7	12.5	73.1	36.00	--	--	42.5	8.5	9.50	4.00	3.4	1.000	8
L5011	26.1	20.00	20.70	28.00	2.80	25.7	12.5	81	--	--	36.00	51.1	8.5	9.50	4.00	3.4	1.000	8
5012	26.1	20.00	20.70	28.00	2.80	25.7	12.5	81	--	40.00	--	51.1	8.5	9.50	4.00	3.4	1.000	8
5013	26.1	20.00	20.70	28.00	2.80	25.7	12.5	81	45.00	--	--	51.1	8.5	9.50	4.00	3.4	1.000	8
509S	26.1	20.00	20.70	28.00	2.80	25.7	12.5	68.9	--	--	28	42.5	8.5	5.20	2.625	2.275	0.625	3.6
5010S	26.1	20.00	20.70	28.00	2.80	25.7	12.5	68.9	--	32	--	42.5	8.5	5.20	2.625	2.275	0.625	3.6
5011S	26.1	20.00	20.70	28.00	2.80	25.7	12.5	68.9	36.00	--	--	42.5	8.5	5.20	2.625	2.275	0.625	3.6
L5011S	26.1	20.00	20.70	28.00	2.80	25.7	12.5	76.7	--	--	36.00	51.1	8.5	5.20	2.625	2.275	0.625	3.6
5012S	26.1	20.00	20.70	28.00	2.80	25.7	12.5	76.7	--	40.00	--	51.1	8.5	5.20	2.625	2.275	0.625	3.6
5013S	26.1	20.00	20.70	28.00	2.80	25.7	12.5	76.7	45.00	--	--	51.1	8.5	5.20	2.625	2.275	0.625	3.6

Frames	BD	AJ	C	BA	AH	BE	BB	BF
509D	25	22.00	73.99	10.37	8.50	1.00	0.25	0.81
5010D	25	22.00	73.99	10.37	8.50	1.00	0.25	0.81
5011D	25	22.00	73.99	10.37	8.50	1.00	0.25	0.81
L5011D	25	22.00	81.89	10.37	8.50	1.00	0.25	0.81
5012D	25	22.00	81.89	10.37	8.50	1.00	0.25	0.81
5013D	25	22.00	81.89	10.37	8.50	1.00	0.25	0.81
509SD	25	22.00	70.80	10.37	5.25	1.00	0.25	0.81
5010SD	25	22.00	70.80	10.37	5.25	1.00	0.25	0.81
5011SD	25	22.00	70.80	10.37	5.25	1.00	0.25	0.81
L5011SD	25	22.00	78.60	10.37	5.25	1.00	0.25	0.81
5012SD	25	22.00	78.60	10.37	5.25	1.00	0.25	0.81
5013SD	25	22.00	78.60	10.37	5.25	1.00	0.25	0.81

Dimension in Inches; Typical dimensions data, not guaranteed.
 Note: See Technical Notes for Drip Cover and Accessory Dimensions



Simotics General Dimensions

XP100 140-320 Frame

Schematics

140-320 Frame Foot Mount

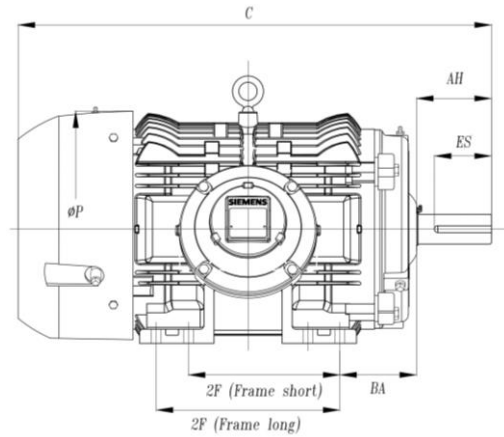
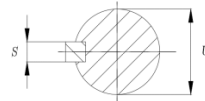
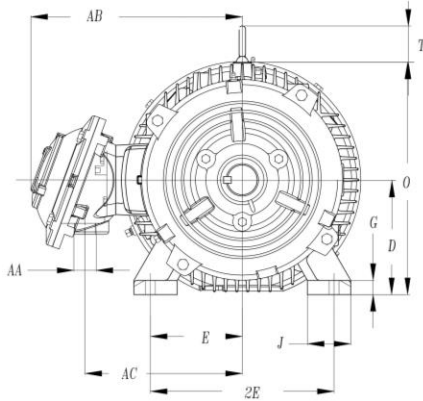

C-Face

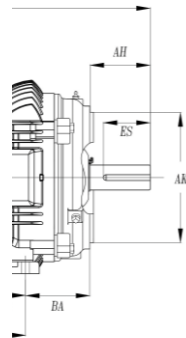
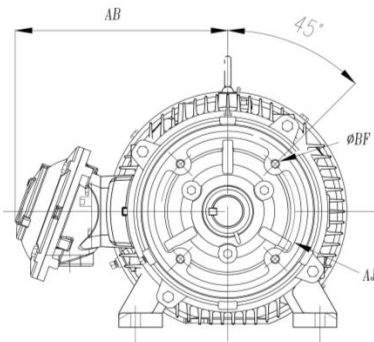

D-Flange

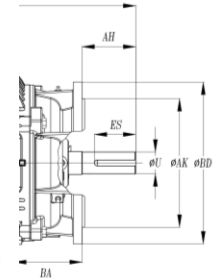
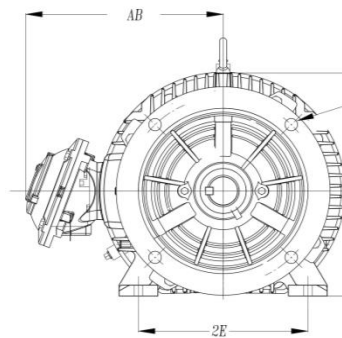

JP Shaft

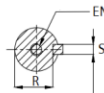
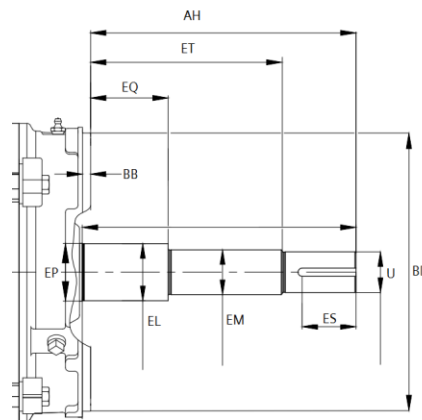

Dimension in Inches; Typical dimensions data, not guaranteed.
 Note: See Technical Notes for Drip Cover and Accessory Dimensions



Simotics General Dimensions

XP100 140-320 Frame

Details

Frame	Poles	C	2F	N-W	P	U	BA	AB	2E	D	O	Keyseat		
												R	S	ES
143T	All	15.27	4	2.25	8.2	0.875	2.25	8.75	5.5	3.5	9.19	0.771	0.188	1.42
145T	All	15.27	5.0	2.25	8.2	0.875	2.25	8.75	5.5	3.5	9.19	0.771	0.188	1.42
182T	All	16.87	4.5	2.75	9.6	1.125	2.75	9.3	7.5	4.5	9.34	0.99	0.250	1.78
184T	All	16.87	5.50	2.75	9.6	1.125	2.75	9.3	7.5	4.5	9.34	0.986	0.250	1.78
213T	All	19.97	5.50	3.38	10.7	1.375	3.5	10.54	8.5	5.25	10.68	1.201	0.312	2.44
215T	All	19.97	7.00	3.38	10.7	1.375	3.5	10.54	8.5	5.25	10.68	1.201	0.312	2.44
254T	All	25.77	8.25	4	12.9	1.625	4.25	11.52	10.0	6.25	12.67	1.416	0.375	2.91
256T	All	25.77	10.00	4	12.9	1.625	4.25	11.52	10.0	6.25	12.67	1.416	0.375	2.91
284T	All	29.40	9.50	4.62	15.8	1.875	4.75	12.85	11.0	7	14.85	1.59	0.500	3.28
286T	All	29.40	11.00	4.62	15.8	1.875	4.75	12.85	11.0	7	14.85	1.59	0.500	3.28
284TS	All	28.03	9.50	3.25	15.8	1.625	4.75	12.85	11.0	7	14.85	1.42	0.375	1.91
286TS	All	28.03	11.00	3.25	15.8	1.625	4.75	12.85	11.0	7	14.85	1.42	0.375	1.91
324T	All	32.08	10.50	5.25	17.7	2.12	5.25	17.35	12.5	8	16.69	1.845	0.500	3.91
326T	All	32.08	12.00	5.25	17.7	2.12	5.25	17.35	12.5	8	16.69	1.845	0.500	3.91
324TS	All	30.58	10.50	3.75	17.7	1.87	5.25	17.35	12.5	8	16.69	1.591	0.500	2.03
326TS	All	30.58	12.00	3.75	17.7	1.87	5.25	17.35	12.5	8	16.69	1.591	0.500	2.03

Frame	Pole	C-Face						
		BA*	AH	AJ	AK	BD	BF #	BF
143TC	All	2.25	2.12	4.5	5.875	6.6	4	3/8-16NC
145TC	All	2.25	2.12	4.50	5.875	6.60	4	3/8-16NC
182TC	All	2.75	2.62	8.50	7.25	8.90	4	1/2-13NC
184TC	All	2.75	2.62	8.50	7.25	8.90	4	1/2-13NC
213TC	All	3.5	3.12	8.50	7.25	8.90	4	1/2-13NC
215TC	All	3.5	3.12	8.50	7.25	8.90	4	1/2-13NC
254TC	All	4.23	3.75	8.50	7.25	9.29	4	1/2-13NC
256TC	All	4.25	3.75	8.50	7.25	9.29	4	1/2-13NC
284TC	All	4.75	4.38	9.00	10.5	11.25	4	1/2"-13NC
286TC	All	4.75	4.38	9.00	10.5	11.25	4	1/2"-13NC
284TSC	All	4.75	3	9.00	10.5	11.25	4	1/2"-13NC
286TSC	All	4.75	3	9.00	10.5	11.25	4	1/2"-13NC
324TC	All	5.25	5	11.00	12.5	14.00	4	5/8"-11NC
326TC	All	5.25	5	11.00	12.5	14.00	4	5/8"-11NC
324TSC	All	5.25	3.5	11.00	12.5	14.00	4	5/8"-11NC
326TSC	All	5.25	3.5	11.00	12.5	14.00	4	5/8"-11NC

Frame	Poles	D-Flange						
		BA*	AH	AJ	AK	BD	BF #	BF
284TD	All	4.75	4.38	12.5	11.0	13.88	4	0.81
286TD	All	4.75	4.38	12.5	11.0	13.88	4	0.81
284TSD	All	4.75	3.00	12.5	11.0	13.88	4	0.81
286TSD	All	4.75	3.00	12.5	11.0	13.88	4	0.81
324TD	All	5.25	5.00	16	14.0	17.87	4	0.81
326TD	All	5.25	5.00	16	14.0	17.87	4	0.81
324TSD	All	5.25	3.50	16	14.0	17.87	4	0.81
326TSD	All	5.25	3.50	16	14.0	17.87	4	0.81

Frame	JP Shaft														
	Shaft							Keyseat			Flange				
	AH	ET	EQ	U	EM	EL	EP	EN	R	S	ES	AJ	BD	BF#	BF
182/4JP	7.342	5.945	1.575	0.875	1.000	1.250	1.378	3/8"-16NC	0.771	0.188	1.650	5.875	6.580	4	3/8"-16NC
213/5JP	8.150	5.890	2.380	1.250	1.370	1.750	1.770	1/2"-13NC	1.112	0.252	1.650	7.250	8.500	4	1/2"-13NC

Dimension in Inches; Typical dimensions data, not guaranteed.
 Note: See Technical Notes for Drip Cover and Accessory Dimensions



Simotics General Dimensions

XP100 360-440 Frame

Schematics

360-440 Frame Foot Mount

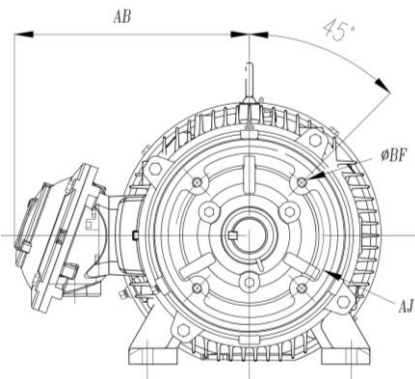
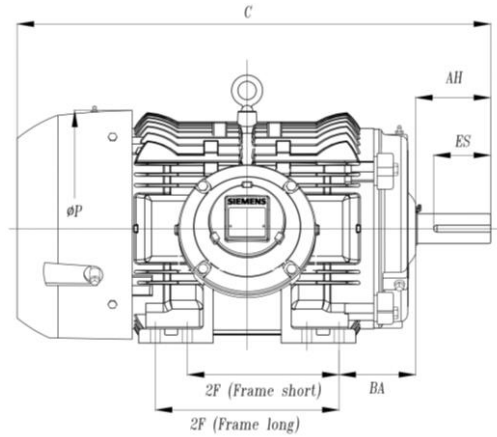
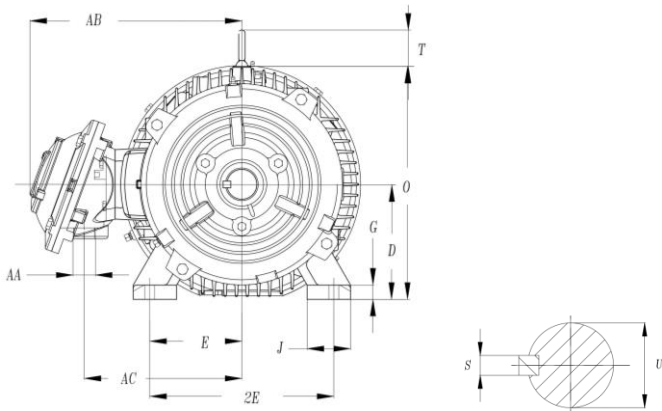

C-Face

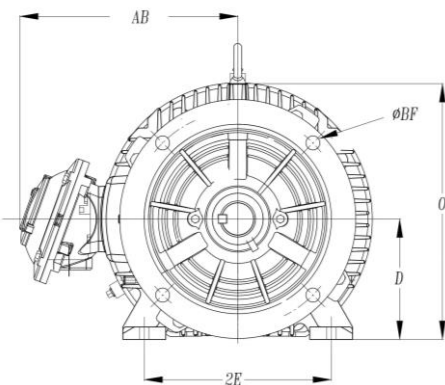
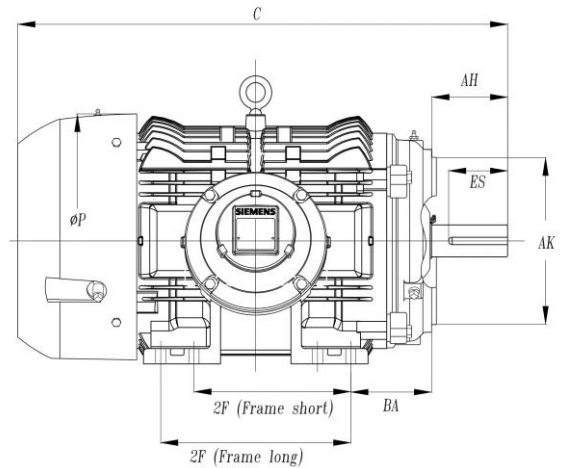

D-Flange

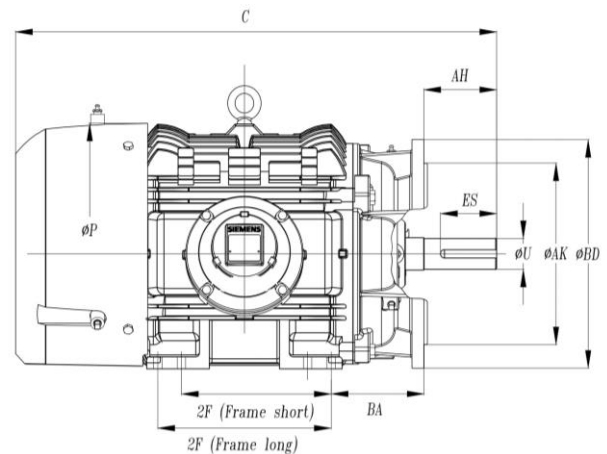

Dimension in Inches; Typical dimensions data, not guaranteed.
 Note: See Technical Notes for Drip Cover and Accessory Dimensions



Simotics General Dimensions

XP100 360-440 Frame

Details

Frame	Poles	C	2F	N-W	P	U	BA	AB	2E	D	O	Keyseat		
												R	S	ES
364T	All	35.28	11.25	5.87	19.6	2.37	5.88	18.18	14.0	9	18.65	2.02	0.625	4.28
365T	All	35.28	12.3	5.87	19.6	2.37	5.88	18.18	14.0	9	18.65	2.02	0.625	4.28
364TS	All	33.16	11.3	3.75	19.6	1.875	5.88	18.18	14.0	9	18.65	1.59	0.500	2.03
365TS	All	33.16	12.25	3.75	19.6	1.875	5.88	18.18	14.0	9	18.65	1.59	0.500	2.03
404T	All	39.52	12.25	7.25	19.6	2.87	6.62	20.34	16.0	10	19.61	2.45	0.750	5.65
405T	All	39.52	13.75	7.25	19.6	2.87	6.62	20.34	16.0	10	19.61	2.45	0.750	5.65
404TS	All	36.52	12.25	4.25	19.6	2.12	6.62	20.34	16.0	10	19.61	1.845	0.500	2.78
405TS	All	36.52	13.75	4.25	19.6	2.12	6.62	20.34	16.0	10	19.61	1.845	0.500	2.78
444T	All	45.58	14.50	8.5	21.7	3.37	7.5	21.59	18.0	11	21.98	2.88	0.875	6.91
445T	All	45.58	16.50	8.5	21.7	3.37	7.5	21.59	18.0	11	21.98	2.88	0.875	6.91
444TS	All	41.83	14.50	4.75	21.7	2.37	7.5	21.59	18.0	11	21.98	2.02	0.625	3.03
445TS	All	41.83	16.50	4.75	21.7	2.37	7.5	21.59	18.0	11	21.98	2.021	0.625	3.03
447T	All	49.08	20.00	8.5	21.7	3.37	7.5	21.59	18.0	11	21.98	2.88	0.875	6.91
447TS	All	45.33	20.00	4.75	21.7	2.37	7.5	21.59	18.0	11	21.98	2.021	0.625	3.03
449T	All	54.08	25.00	8.5	21.7	3.37	7.5	23.46	18.0	11	21.98	2.88	0.875	6.912
449TS	All	50.33	25.00	4.75	21.7	2.37	7.5	23.46	18.0	11	21.98	2.021	0.875	3.03

Frame	Pole	C-Face						
		BA*	AH	AJ	AK	BD	BF #	BF
364TC	All	6.62	5.62	11	12.5	14	8	5/8"-11NC
365TC	All	6.62	5.62	11.00	12.5	14.00	8	5/8"-11NC
364TSC	All	6.62	3.5	11.00	12.5	14.00	8	5/8"-11NC
365TSC	All	6.62	3.5	11.00	12.5	14.00	8	5/8"-11NC
404TC	All	6.62	7	11.00	12.5	15.50	8	5/8"-11NC
405TC	All	6.62	7	11.00	12.5	15.50	8	5/8"-11NC
404TSC	All	6.62	4	11.00	12.5	15.50	8	5/8"-11NC
405TSC	All	6.62	4	11.00	12.5	15.50	8	5/8"-11NC
444TC	All	7.5	8.25	14.00	16	18.00	8	5/8"-11NC
445TC	All	7.5	8.25	14.00	16	18.00	8	5/8"-11NC
444TSC	All	7.5	4.5	14.00	16	18.00	8	5/8"-11NC
445TSC	All	7.5	4.5	14.00	16	18.00	8	5/8"-11NC
447TC	All	7.5	8.25	14.00	16	18.00	8	5/8"-11NC
447TSC	All	7.5	4.5	14.00	16	18.00	8	5/8"-11NC
449TC	All	7.5	8.25	14.00	16	18.00	8	5/8"-11NC
449TSC	All	7.5	4.5	14.00	16	18.00	8	5/8"-11NC

Frame	Poles	D-Flange						
		BA*	AH	AJ	AK	BD	BF #	BF
364TD	All	6.62	5.62	16	14	18	4	0.81
365TD	All	6.62	5.62	16	14	18	4	0.81
364TSD	All	6.62	3.5	16	14	18	4	0.81
365TSD	All	6.62	3.5	16	14	18	4	0.81
404TD	All	6.62	7	16	14	22	8	0.81
405TD	All	6.62	7	16	14	22	8	0.81
404TSD	All	6.62	4	16	14	22	8	0.81
405TSD	All	6.62	4	16	14	22	8	0.81
444TD	All	7.5	8.25	14	18.0	22.00	8	0.81
445TD	All	7.5	8.25	14	18.0	22.00	8	0.81
444TSD	All	7.5	4.50	14	18.0	22.00	8	0.81
445TSD	All	7.5	4.50	14	18.0	22.00	8	0.81
447TD	All	7.5	8.25	14	18.0	22.00	8	0.81
447TSD	All	7.5	4.50	14	18.0	22.00	8	0.81
449TD	All	7.5	8.25	14	18.0	22.00	8	0.81
449TSD	All	7.5	4.50	14	18.0	22.00	8	0.81

Dimension in Inches; Typical dimensions data, not guaranteed.
 Note: See Technical Notes for Drip Cover and Accessory Dimensions



Simotics General Dimensions

SD10 MS 140-320 Frame

Schematics

140-320 Frame Foot Mount

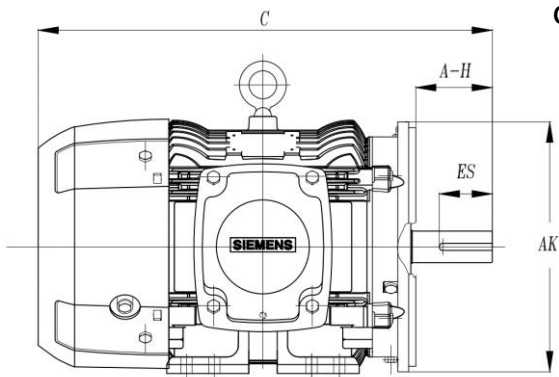
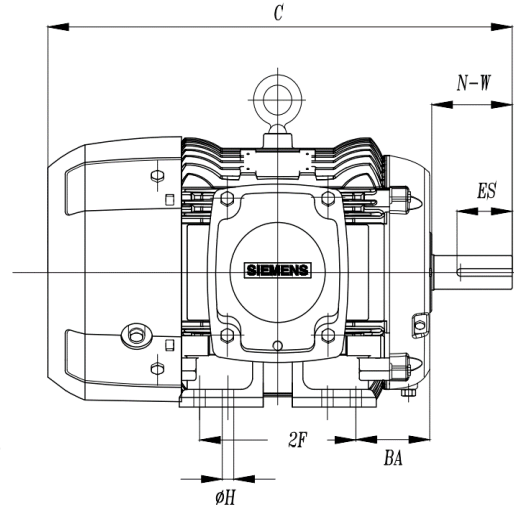
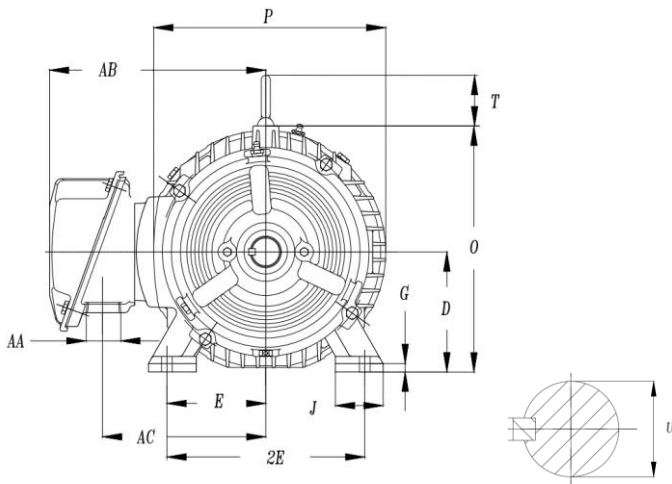

C-Face

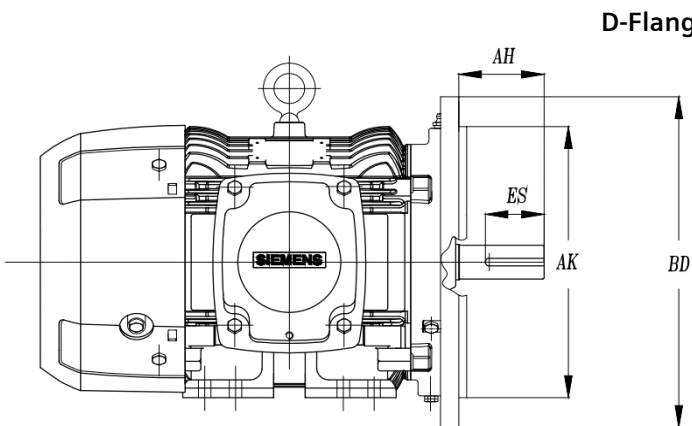
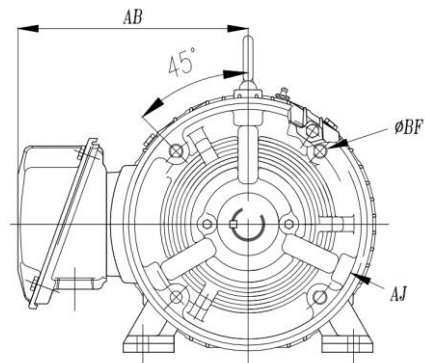

D-Flange

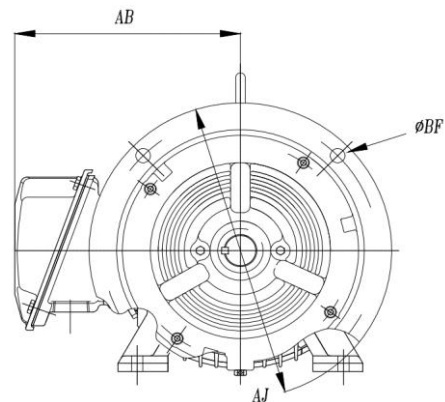

Dimension in Inches; Typical dimensions data, not guaranteed.
 Note: See Technical Notes for Drip Cover and Accessory Dimensions



Simotics General Dimensions

SD10 MS 140-320 Frame

Details

Frame	Poles	C	2F	N-W	P	U	BA	AB	2E	D	O	Keyseat		
												R	S	ES
143T	All	14.37	4	2.25	7.6	0.875	2.25	7	5.5	3.5	7.28	0.771	0.188	1.41
145T	All	14.37	5.0	2.25	7.6	0.875	2.25	7	5.5	3.5	7.28	0.771	0.188	1.41
182T	All	16.68	4.5	2.75	8.7	1.125	2.75	6.94	7.5	4.5	8.87	0.986	0.250	1.81
184T	All	16.68	5.50	2.75	8.7	1.125	2.75	6.94	7.5	4.5	8.87	0.986	0.250	1.81
213T	All	20.65	5.50	3.38	10.3	1.375	3.5	8.27	8.5	5.25	10.41	1.201	0.312	2.44
215T	All	20.65	7.00	3.38	10.3	1.375	3.5	8.27	8.5	5.25	10.41	1.201	0.312	2.44
254T	All	26.16	8.25	4	12.4	1.625	4.25	9.35	10.0	6.25	12.43	1.416	0.375	2.91
256T	All	26.16	10.00	4	12.4	1.625	4.25	9.35	10.0	6.25	12.43	1.416	0.375	2.91
284T	All	27.40	9.50	4.63	15.5	1.875	13.4	4.75	11.0	7	14.19	1.59	0.500	3.25
286T	All	28.90	11.00	4.63	15.5	1.875	13.4	4.75	11.0	7	14.19	1.59	0.500	3.25
284TS	All	26.00	9.50	3.25	15.5	1.625	13.4	4.75	11.0	7	14.19	1.42	0.375	1.88
286TS	All	27.50	11.00	3.25	15.5	1.625	13.4	4.75	11.0	7	14.19	1.42	0.375	1.88
324T	All	32.00	10.50	5.25	17.1	2.125	15.75	5.25	12.5	8	15.94	1.85	0.500	3.88
326T	All	32.00	12.00	5.25	17.1	2.125	15.75	5.25	12.5	8	15.94	1.85	0.500	3.88
324TS	All	30.00	10.50	3.75	17.1	1.875	15.75	5.25	12.5	8	15.94	1.59	0.500	2
326TS	All	30.00	12.00	3.75	17.1	1.875	15.75	5.25	12.5	8	15.94	1.59	0.500	2

Frame	Pole	C-Face						
		BA*	AH	AJ	AK	BD	BF #	BF
143TC	All	2.25	2.12	5.875	4.5	6.6	4	3/8"-16NC
145TC	All	2.25	2.12	5.88	4.5	6.60	4	3/8"-16NC
182TC	All	2.75	2.62	7.25	8.5*	8.90	4	1/2"-13NC
184TC	All	2.75	2.62	7.25	8.5*	8.90	4	1/2"-13NC
213TC	All	3.5	3.12	7.25	8.5	8.90	4	1/2"-13NC
215TC	All	3.5	3.12	7.25	8.5	8.90	4	1/2"-13NC
254TC	All	4.25	3.75	7.25	8.5	9.30	4	1/2"-13NC
256TC	All	4.25	3.75	7.25	8.5	9.30	4	1/2"-13NC
284TC	All	4.75	4.38	9.00	10.5	10.75	4	1/2"-13NC
286TC	All	4.75	4.38	9.00	10.5	10.75	4	1/2"-13NC
284TSC	All	4.75	3	9.00	10.5	10.75	4	1/2"-13NC
286TSC	All	4.75	3	9.00	10.5	10.75	4	1/2"-13NC
324TC	All	5.25	5	11.00	12.5	12.75	4	5/8"-11NC
326TC	All	5.25	5	11.00	12.5	12.75	4	5/8"-11NC
324TSC	All	5.25	3.5	11.00	12.5	12.75	4	5/8"-11NC
326TSC	All	5.25	3.5	11.00	12.5	12.75	4	5/8"-11NC

Frame	Poles	D-Flange						
		BA*	AH	AJ	AK	BD	BF #	BF
143TD	All	2.25	2.25	10.0	9.0	10.90	4	0.53
145TD	All	2.25	2.25	10.0	9.0	10.90	4	0.53
182TD	All	2.75	2.75	10.0	9.0	11.00	4	0.53
184TD	All	2.75	2.75	10	9.0	11.00	4	0.53
213TD	All	3.5	3.38	10	9.0	10.90	4	0.53
215TD	All	3.5	3.38	10	9.0	10.90	4	0.53
254TD	All	4.25	4.00	12.5	11.0	13.90	4	0.81
256TD	All	4.25	4.00	12.5	11.0	13.90	4	0.81
284TD	All	4.75	4.62	12.5	11.0	13.88	4	0.81
286TD	All	4.75	4.62	12.5	11.0	13.88	4	0.81
284TSD	All	4.75	3.25	12.5	11.0	13.88	4	0.81
286TSD	All	4.75	3.25	12.5	11.0	13.88	4	0.81
324TD	All	5.25	5.25	16	14.0	17.88	4	0.81
326TD	All	5.25	5.25	16	14.0	17.88	4	0.81
324TSD	All	5.25	3.75	16	14.0	17.88	4	0.81
326TSD	All	5.25	3.75	16	14.0	17.88	4	0.81

Dimension in Inches; Typical dimensions data, not guaranteed.
 Note: See Technical Notes for Drip Cover and Accessory Dimensions



Introduction
 Special Features
 Motor Selection and Pricing
 Options Selection and Pricing
 Typical Performance Details
 General Dimensions
 MV449 Frame
 Indexes

Simotics General Dimensions

SD10 MS 360-440 Frame

Schematics

360-440 Frame Foot Mount

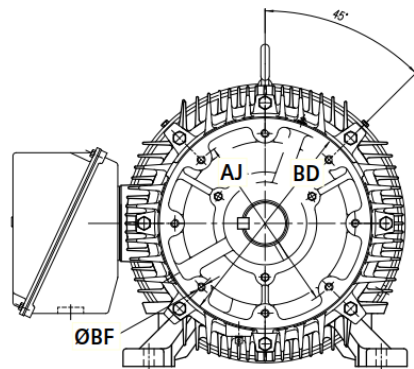
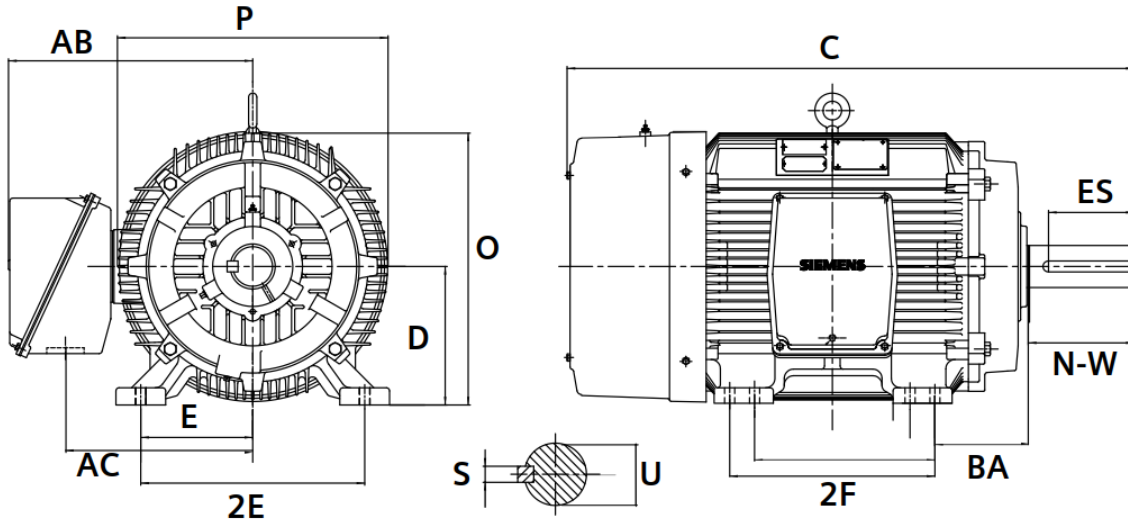

C-Face

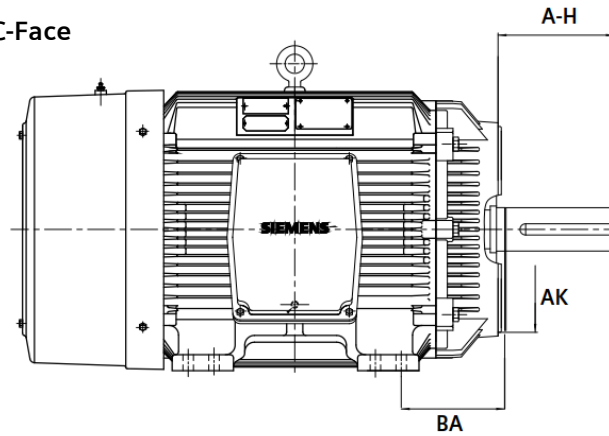

D-Flange

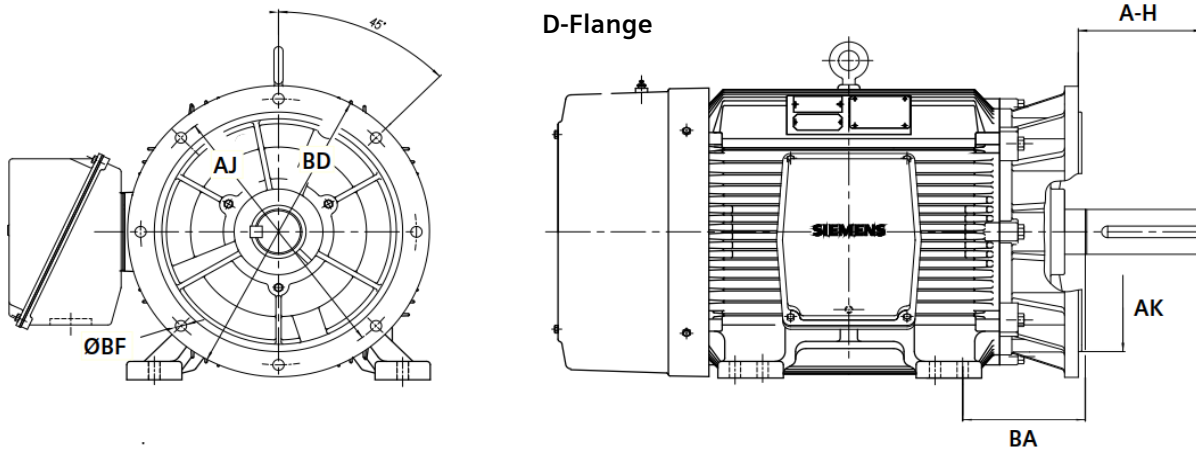

Dimension in Inches; Typical dimensions data, not guaranteed.
 Note: See Technical Notes for Drip Cover and Accessory Dimensions



Simotics General Dimensions

SD10 MS 360-440 Frame

Details

Frame	Poles	C	2F	N-W	P	U	BA	AB	2E	D	O	Keyseat		
												R	S	ES
364T	All	34.20	11.25	5.88	18.5	2.375	17.69	5.88	14.0	9	17.81	2.02	0.625	4.25
365T	All	34.20	12.3	5.88	18.5	2.375	17.69	5.88	14.0	9	17.81	2.02	0.625	4.25
364TS	All	32.10	11.3	3.75	18.5	1.875	17.69	5.88	14.0	9	17.81	1.59	0.500	2
365TS	All	32.10	12.25	3.75	18.5	1.875	17.69	5.88	14.0	9	17.81	1.59	0.500	2
404T	All	39.50	12.25	7.25	19.6	2.875	17.5	6.63	16.0	10	19.90	2.45	0.750	5.63
405T	All	39.50	13.75	7.25	19.6	2.875	17.5	6.63	16.0	10	19.90	2.45	0.750	5.63
404TS	All	36.50	12.25	4.25	19.6	2.125	17.5	6.63	16.0	10	19.90	1.85	0.500	2.75
405TS	All	36.50	13.75	4.25	19.6	2.125	17.5	6.63	16.0	10	19.90	1.85	0.500	2.75
404TS	All	36.40	12.25	4.25	19.6	2.125	6.62	18.38	16.0	10	19.60	1.845	0.500	2.75
405TS	All	36.40	13.75	4.25	19.6	2.125	6.62	18.38	16.0	10	19.60	1.845	0.500	2.75
444T	All	45.60	14.50	8.5	21.7	3.375	19.94	7.5	18.0	11	21.90	2.88	0.875	6.88
445T	All	45.60	16.50	8.5	21.7	3.375	19.94	7.5	18.0	11	21.90	2.88	0.875	6.88
444TS	All	41.80	14.50	4.75	21.7	2.375	19.94	7.5	18.0	11	21.90	2.02	0.625	3
445TS	All	41.80	16.50	4.75	21.7	2.375	19.94	7.5	18.0	11	21.90	2.02	0.625	3
447T	All	49.10	20.00	8.5	21.8	3.375	19.94	7.5	18.0	11	21.90	2.88	0.875	6.88
447TS	All	45.40	20.00	4.75	21.8	2.375	19.94	7.5	18.0	11	21.90	2.02	0.625	3
449T	All	54.10	25.00	8.5	21.8	3.375	22	7.5	18.0	11	21.90	2.88	0.875	6.88
449TS	All	50.30	25.00	4.75	21.8	2.375	22	7.5	18.0	11	21.90	2.02	0.625	3
S449LS	All	67.10	25.00	9.12	25.4	3.625	23.01	7.5	18.0	11	23.40	3.13	0.875	7.5
S449SS	All	67.10	25.00	5.25	25.4	2.625	23.01	7.5	18.0	11	23.40	2.28	0.625	3.5

Frame	Pole	C-Face						
		BA*	AH	AJ	AK	BD	BF #	BF
364TC	All	5.88	5.62	11.00	12.5	12.75	8	5/8"-11NC
365TC	All	5.88	5.62	11.00	12.5	12.75	8	5/8"-11NC
364TSC	All	5.88	3.5	11.00	12.5	12.75	8	5/8"-11NC
365TSC	All	5.88	3.5	11.00	12.5	12.75	8	5/8"-11NC
404TC	All	6.63	7	11.00	12.5	13.50	8	5/8"-11NC
405TC	All	6.63	7	11.00	12.5	13.50	8	5/8"-11NC
404TSC	All	6.63	4	11.00	12.5	13.50	8	5/8"-11NC
405TSC	All	6.63	4	11.00	12.5	13.50	8	5/8"-11NC
444TC	All	7.5	8.25	14.00	16	16.62	8	5/8"-11NC
445TC	All	7.5	8.25	14.00	16	16.62	8	5/8"-11NC
444TSC	All	7.5	4.5	14.00	16	16.62	8	5/8"-11NC
445TSC	All	7.5	4.5	14.00	16	16.62	8	5/8"-11NC
447TC	All	7.5	8.25	14.00	16	16.62	8	5/8"-11NC
447TSC	All	7.5	4.5	14.00	16	16.62	8	5/8"-11NC
449TC	All	7.5	8.25	14.00	16	16.62	8	5/8"-11NC
449TSC	All	7.5	4.5	14.00	16	16.62	8	5/8"-11NC

Frame	Poles	D-Flange						
		BA*	AH	AJ	AK	BD	BF #	BF
364TD	All	5.88	5.88	16.0	14.0	17.88	4	0.81
365TD	All	5.88	5.88	16.0	14.0	17.88	4	0.81
364TSD	All	5.88	3.75	16.0	14.0	17.88	4	0.81
365TSD	All	5.88	3.75	16	14.0	17.88	4	0.81
404TD	All	6.63	7.25	20	18.0	21.88	8	0.81
405TD	All	6.63	7.25	20	18.0	21.88	8	0.81
404TSD	All	6.63	4.25	20	18.0	21.88	8	0.81
405TSD	All	6.63	4.25	20	18.0	21.88	8	0.81
444TD	All	7.5	8.50	20	18.0	21.88	8	0.81
445TD	All	7.5	8.50	20	18.0	21.88	8	0.81
444TSD	All	7.5	4.75	20	18.0	21.88	8	0.81
445TSD	All	7.5	4.75	20	18.0	21.88	8	0.81
447TD	All	7.5	8.50	20	18.0	21.88	8	0.81
447TSD	All	7.5	4.75	20	18.0	21.88	8	0.81
449TD	All	7.5	8.50	20	18.0	21.88	8	0.81
449TSD	All	7.5	4.75	20	18.0	21.88	8	0.81

Dimension in Inches; Typical dimensions data, not guaranteed.
 Note: See Technical Notes for Drip Cover and Accessory Dimensions



Introduction
 Special Features
 Motor Selection and Pricing
 Options Selection and Pricing
 Typical Performance Details
 General Dimensions
 MV449 Frame
 Indexes

Simotics General Dimensions

HP100 and LP100

Schematics

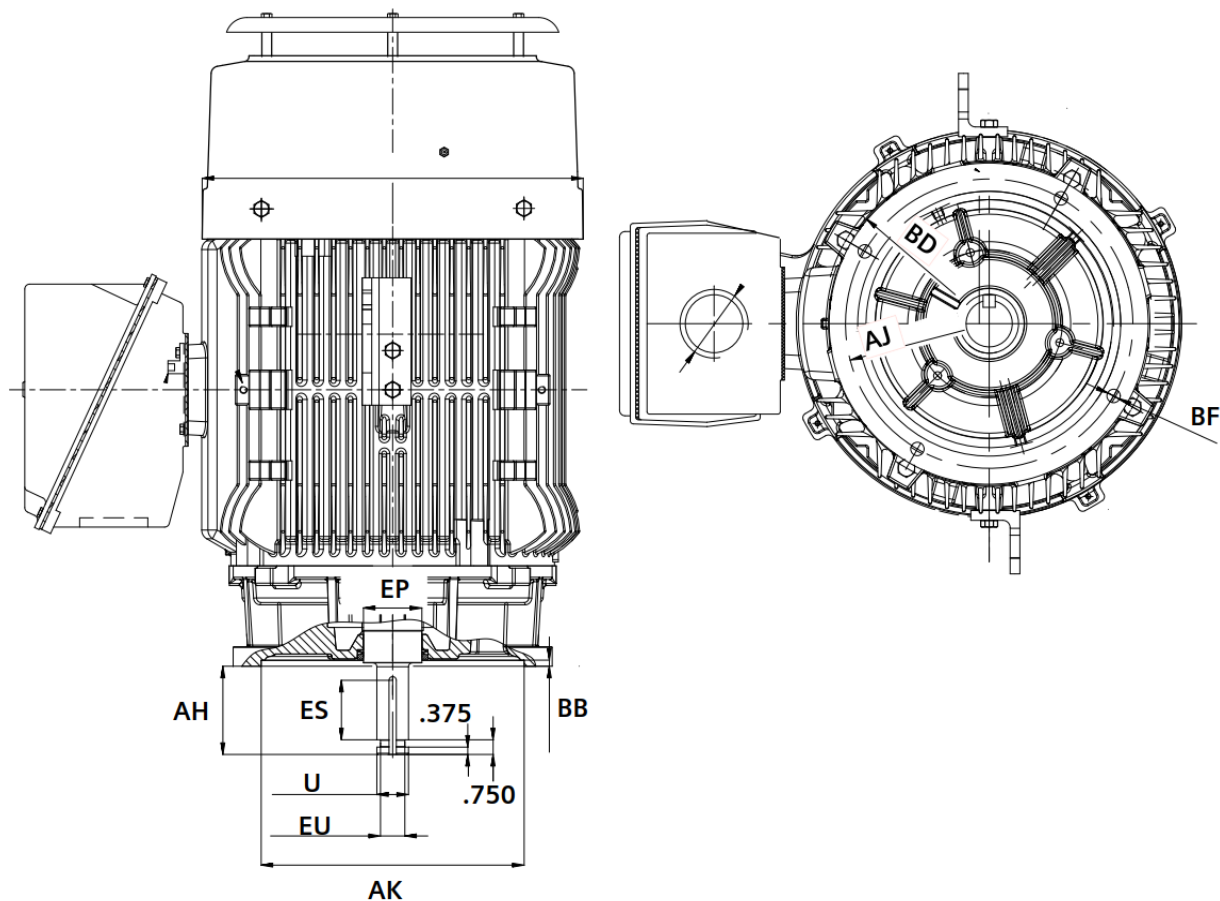

Dimension in Inches; Typical dimensions data, not guaranteed.



Simotics General Dimensions

HP100 and LP100

Details

Frame	U	EU	EP	BD	AH	AJ	AK	BF	Keyseat		
									R	S	ES
182/4LP	1.125	0.875	1.18	10.0	2.76	9.125	8.25	0.438	0.986	0.250	2.03
213/5LP	1.625	1.250	1.77	10.0	2.76	9.125	8.25	0.438	1.416	0.375	2.03
254/6LP	1.625	1.250	1.77	10.0	2.80	9.125	8.25	0.438	1.416	0.375	2.03
284/6LP	1.125	0.875	1.97	10.0	2.8	9.13	8.25	0.438	0.986	0.250	1.35
284/6LPH	2.125	1.750	2.36	16.5	4.5	14.75	13.50	0.688	1.845	0.500	3.00
324/6LP	2.125	1.750	2.36	16.5	4.5	14.75	13.50	0.688	1.845	0.500	3.03
364/5LP	2.125	1.750	3.00	16.5	4.5	14.75	13.50	0.688	1.845	0.500	3.03
404/5LP	2.125	1.750	3.00	16.5	4.5	14.75	13.50	0.688	1.845	0.500	3.00
444/5LP	2.125	1.750	3.00	16.5	4.5	14.75	13.50	0.688	1.845	0.500	3.00
447/9LP	2.125	1.750	3.00	16.5	4.5	14.75	13.50	0.688	1.845	0.500	3.00

Frame	U	EU	EP	BD	AH	AJ	AK	BF	Keyseat		
									R	S	ES
182/4HP	1.125	0.875	1.18	10.0	2.76	9.125	8.25	0.438	0.986	0.250	2.03
213/5HP	1.125	0.874	1.77	10.0	2.76	9.125	8.25	0.438	0.896	0.250	2.03
254/6HP	1.125	0.875	1.77	10.0	2.76	9.125	8.25	0.438	0.986	0.250	2.03
284/6HP	1.125	0.875	1.97	10.0	2.75	9.125	8.3	0.438	0.986	0.250	1.35
324/6HP	1.625	1.250	2.36	16.5	4.5	14.75	13.5	0.688	1.416	0.375	3.09
364/5HP	1.250	1.625	3.00	16.5	4.5	14.75	13.5	0.688	1.416	0.375	3.03
404/5HP	1.625	1.250	3.00	16.5	4.5	14.75	13.5	0.688	1.416	0.375	3.00
444/5HP	2.125	1.750	3.00	16.5	4.5	14.75	13.5	0.688	1.845	0.500	3.00
447/9HP	2.125	1.750	3.00	16.5	4.5	14.75	13.5	0.688	1.845	0.500	3.00

Dimension in Inches; Typical dimensions data, not guaranteed.



Simotics General Dimensions

GP100A/GP100 140-250 Frame
Conduit Boxes

Schematic
Aluminum Box

Figure 1

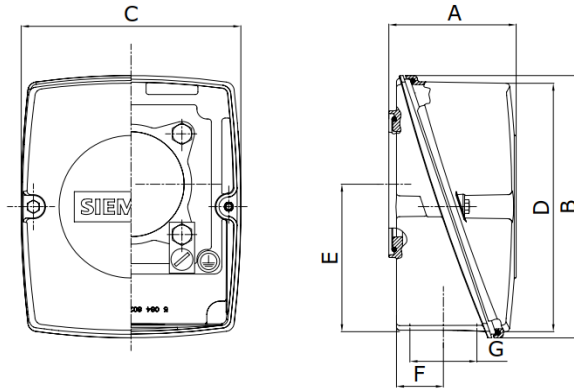

Figure 2

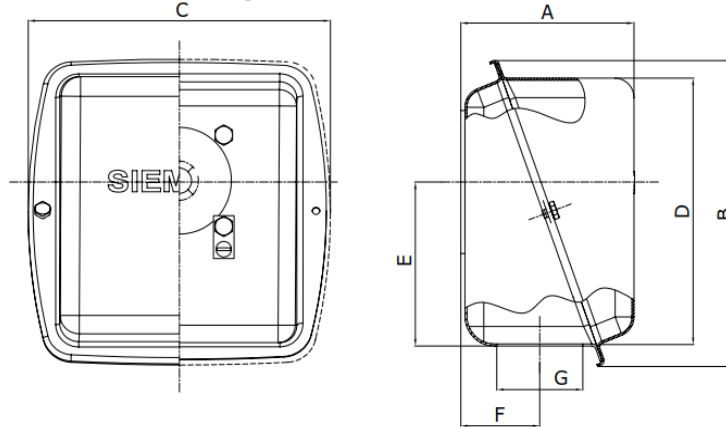
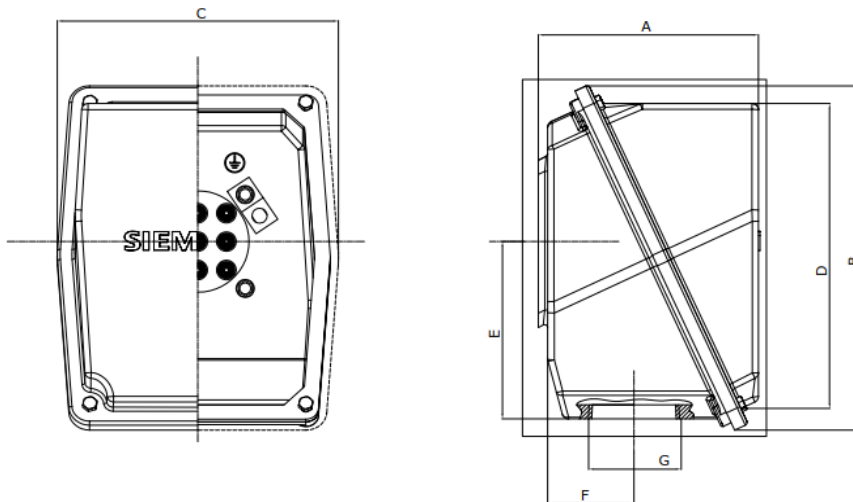

Figure 3



Typical dimensions data, not guaranteed.



Simotics General Dimensions

GP100A/GP100 140-250 Frame Conduit Boxes

Details Aluminum Box

Frames	External Dimensions (in)							Vol Int aprox (in ³)	No.screws on cover	Fig	Material
	A	B	C	D	EP	F	G				
140	2.79	5.31	4.41	4.98	2.69	0.95	0.75 NPT	37	2	1	Cast Aluminum
180	2.79	5.31	4.41	4.98	2.69	0.95	0.75 NPT	37	2	1	Cast Aluminum
210	3.30	6.89	5.71	6.52	3.87	1.18	1 NPT	87	2	1	Cast Aluminum
250	3.30	6.89	5.71	6.52	3.87	1.18	1.25 NPT	87	2	1	Cast Aluminum
280	5.00	8.60	8.70	7.48	4.60	2.28	2 NPT	230	2	2	Stamped Steel
320	5.00	8.60	8.70	7.48	4.60	2.28	2.5 NPT	230	2	2	Stamped Steel
360	7.44	9.94	9.69	9.69	4.72	3.10	3 NPT	465	2	2	Stamped Steel
400	7.44	9.94	9.69	9.69	4.72	3.10	3 NPT	465	2	2	Stamped Steel
440	8.60	13.59	10.99	12.03	7.00	3.37	3 NPT	748	4	3	Cast Iron

Typical dimensions data, not guaranteed.



Simotics General Dimensions

SD100/SD100 IEEE841/SD10 MS
Conduit Boxes

Schematic

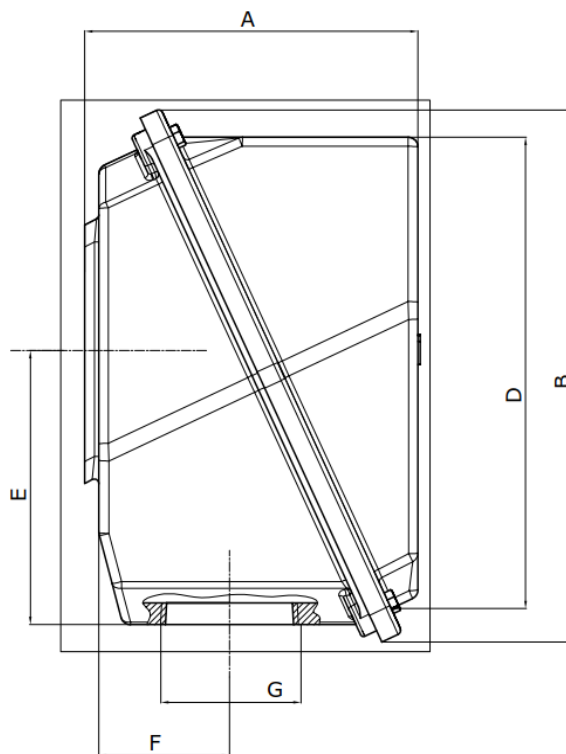
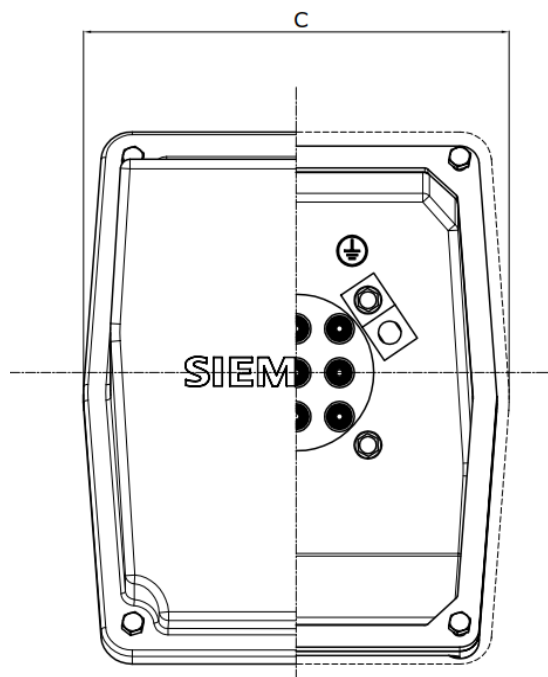

Typical dimensions data, not guaranteed.



Simotics General Dimensions

SD100/SD100 IEEE841/SD10 MS Conduit Boxes

Details

Frames	External Dimensions (in)							Vol Int aprox (in3)	No.screws on top
	A	B	C	D	EP	F	G		
140	3.23	5.98	4.96	5.46	2.28	1.18	0.75 NPT	41	4
180	3.23	5.98	4.96	5.46	2.28	1.18	0.75 NPT	41	4
210	4.24	7.11	5.94	6.42	3.43	1.69	1 NPT	86	4
250	4.24	7.11	5.94	6.42	3.43	1.69	1.25 NPT	86	4
280	6.00	8.19	7.74	8.19	4.75	2.37	1.5 NPT	222	4
320	7.05	11.07	8.92	9.90	5.50	3.00	2 NPT	400	4
360	8.60	13.59	10.99	12.03	7.00	3.37	3 NPT	465	4
400	8.60	13.59	10.99	12.03	7.00	3.37	3 NPT	465	4
444-447	8.60	13.59	10.99	12.03	7.00	3.37	3 NPT	748	4
449	10.55	16.75	14.00	15.01	8.50	5.00	3 NPT	1696	4
S449	10.55	16.75	14.00	15.01	8.50	5.00	4 NPT	1696	4

Typical dimensions data, not guaranteed.



Simotics General Dimensions

XP100/XP100 ID1 Conduit Boxes

Schematic & Details

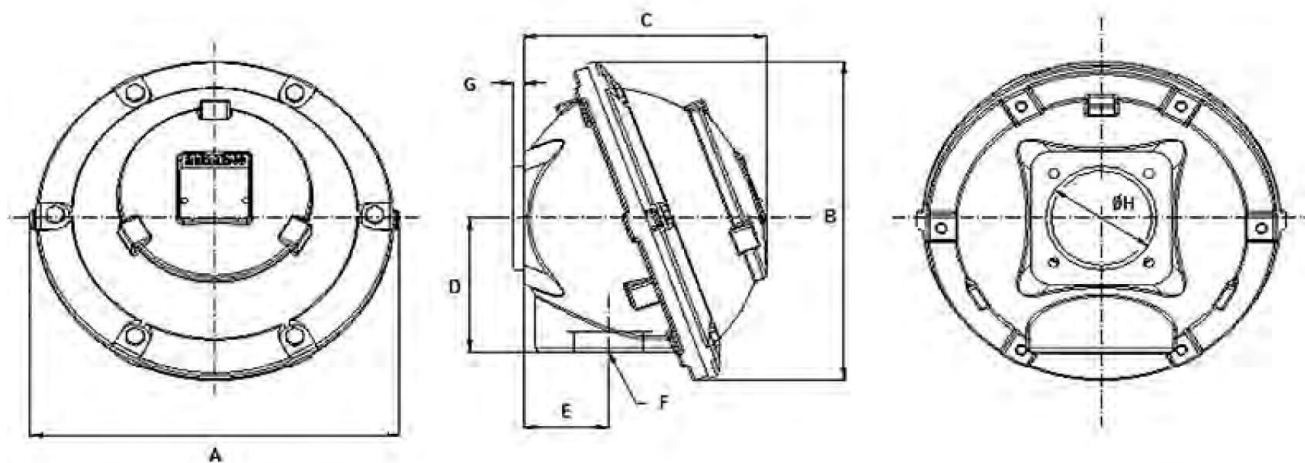

Frames	External Dimensions (in)								Vol Int aprox (in ³)	No.screws on top
	A	B	C	D	EP	F	G	H		
140	7.28	6.65	4.07	2.56	1.61	3/4"-14 NPT	0.35	2.20	39.0	4
180	7.28	6.65	4.07	2.56	1.61	3/4"-14 NPT	0.35	2.20	39.0	4
210	8.07	7.40	4.66	2.95	1.73	1"-11.5NPT	0.35	2.83	64.0	4
250	8.07	7.40	4.66	2.95	1.73	1"-11.5NPT	0.35	2.83	64.0	4
280	8.07	7.40	4.66	2.95	1.73	1.5"-11.5NPT	0.35	2.83	64.0	4
320	12.00	11.13	7.90	4.65	2.76	2"-11.5NPT	0.35	3.62	278.4	6
360	12.00	11.13	7.90	4.65	2.76	3"-8NPT	0.35	3.62	278.4	6
400	14.09	13.11	9.88	5.83	4.17	3"-8NPT	0.35	4.72	552.0	6
444/445	14.09	13.11	9.88	5.83	4.17	3"-8NPT	0.35	4.72	552.0	6
447	14.09	13.11	9.88	5.83	4.17	3"-8NPT	0.35	4.72	552.0	6
449	17.24	16.14	11.75	6.89	5.45	3"-8NPT	0.35	4.72	972.0	6

Dimension in Inches; Typical dimensions data, not guaranteed.

Note: See Technical Notes for Drip Cover and Accessory Dimensions



Simotics General Dimensions

SD200
Severe Duty

Conduit Boxes
Cast Iron

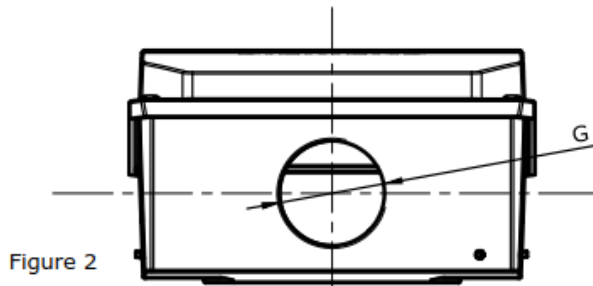

Figure 2

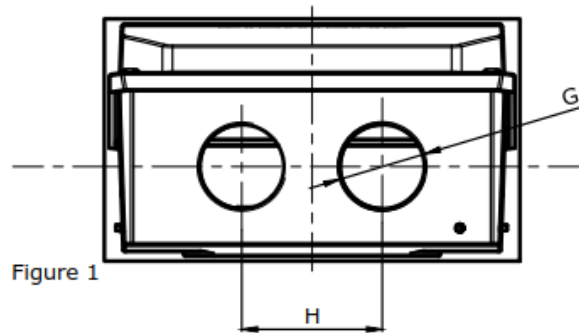
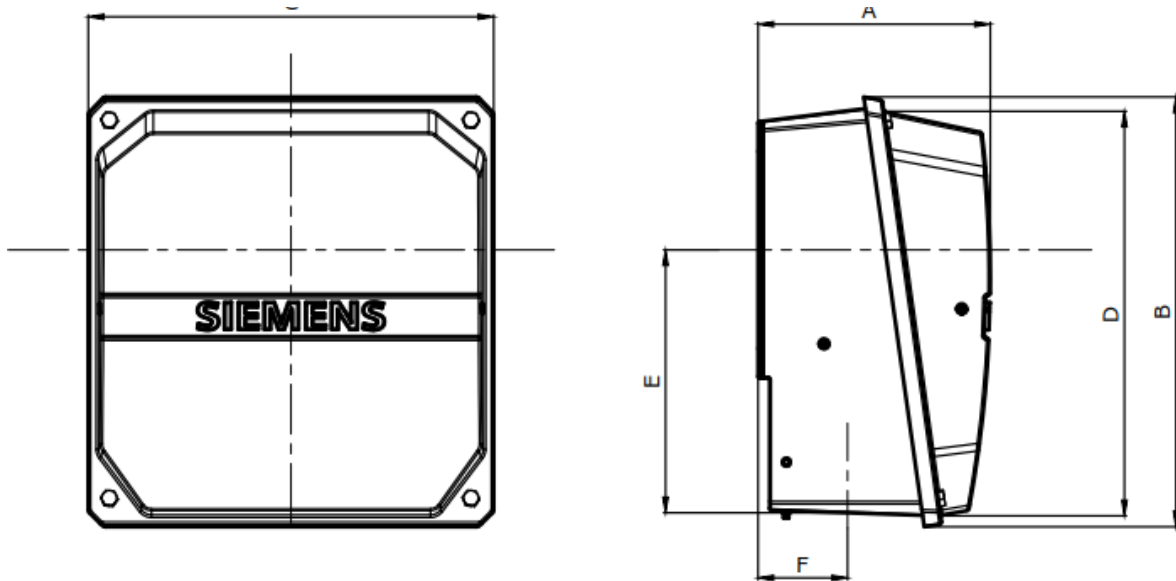

Figure 1



Frame	General Dimensions							Qty.	H	Figure	Approx. internal volume (in ³)	Number of cover bolts
	A	B	C	D	E	F	G					
500	11.73	21.71	20.47	20.43	13.28	4.52	4 - NPT	2	7.10	1	3480	4
500	11.73	21.71	20.47	20.43	13.28	4.52	5 - NPT	1	--	2	3480	4

Note: Standard box will have a single entry hole, two hole box is on request only.
Typical dimensions data, not guaranteed.







SIMOTICS Advantage Series Motors

MV449

Introduction

Siemens Advantage Series motors are designed and built to operate as the premier industry workhorse and are ideal for power generation, pulp and paper, waste-water, chemical and petrochemical industries. Fans, compressors, pumps and conveyors are some of the many applications. These motors are designed to meet or exceed the NEMA Premium® efficiency (MG1 Table 12-12) as well as the most stringent industry standards of IEEE 841). As standard, these motors come equipped with stator RTDs and a space heater as well as with the ability to choose from a wide selection of options which provide higher flexibility and reliability to a diversity of operating conditions. The construction of these motors is backed up by its 3 year warranty.

Performance Specification		
HP Range	3600 RPM	150 - 350 HP
	1800 RPM	150 - 350 HP
	1200 RPM	150 - 250 HP
Frame Size	440	449 - S449
Standard Voltage (3~ 60 Hz)	--	2300V/4000V
Efficiency	NEMA Standard	150-200 HP
	NEMA Premium® (MG1 -Table 12-12)	250 HP +
Service Factor	--	1.15 @ 40°C
Insulation	Non-hygroscopic	Class F
Temperature Rise	Class B	@ 1.0SF
	Class F	@ 1.15SF
Conduit Box (Oversized)	Oversized	Fabricated with Removable Bottom Plate
Fan Cover	--	Cast Iron
Cooling Fan	Uni-Directional S449 2P - CW Facing Shaft	Anti Static Reinforced Polyamide
	Bi-Directional All 449 & S449 4P+	Anti Static Reinforced Polyamide & Polypropylene - 449, Bronze - S449
Stator	--	Form Wound Copper
Rotor	--	Die Cast Aluminum
Ingress Protection	NEMA	IP54
Hazardous Location	--	CL 1, Div 2 Gr. B,C or D Temp Code T3
Inverter Duty	Variable Torque 10:1	449-S449
	Constant Torque CT 2:1	449-S449
		 

SIMOTICS Advantage Series Motors

MV449

Frame and End Shields

The SIMOTICS Advantage Series motor, MV449, feature cast iron frame, end shields and an oversized fabricated main terminal box with a removable bottom plate for easy installation. These characteristics, its high strength zinc-plated hardware, epoxy paint and stainless steel nameplate provide exceptional structural integrity and resistant to rust and corrosion, and make them suitable for applications in harsh environments.

Rotor and Stator Windings

An exclusive, leading-edge die cast aluminum rotor bar design provides improved efficiency and reduces operating costs. Each die cast aluminum rotor assembly is dynamically balanced for extended bearing life and includes a high-strength carbon steel (C1045 or C4140) shaft for maximum rotor performance.

The stator is manufactured with premium electrical C5 grade steel lamination and copper electrical magnet wire that furthers the reduction in losses

Insulation

The proprietary Siemens MiCLAD (TM) form wound stator insulation system provides the ultimate in electrical protection, as well as mechanical and electrical strength for long service life. It features a highly engineered, sealed epoxy mica design for optimum electrical and ambient operating performance and meets or exceeds NEMA MG1-20 sealed winding standards. With a Class F non-hygroscopic insulation system, NEMA Class B temperature rise, this system provides an extra margin of thermal life as well.

Cooling System

All fans are good for hazardous Class II areas, are locked and keyed to the shaft and are bi-directional except for the S449 2pole ratings. Its low-inertia design reduces windage losses, improves airflow, reduces noise and provides dependable cooling. Cast Iron fan covers are provided for all frames sizes.

Bearings

Single shielded bearings are used for better bearing protection against contaminants.



SIMOTICS Advantage Series Motors

MV449 Standard Price

MV449 (Cast Iron Frame) Rotor: Die Cast Aluminum Eff: NEMA Premium for 250HP						Standard Delivery Times:						Stock	
												Quick Mod	
												Non-Stock	
Power HP	Speed Rpm	NEMA Frame	Base Part Number ■■■ = digits 2,3, 10, last 3	Voltage	Digits 2,3		Digit 10		last 3 (defines digit 11)		Eff	Weight Lbs	
					Main Group: Non-Hazardous	Main Group: Hazardous, Div 2	DOL	Inverter, filtered output	DOL (only if digit 10 is A)	Inverter, filtered output (only if digit 10 is T)			
					LA	NS	A	T	L1C	L2S			
												List price\$	
150	3600	449TS	1■■3462-2A■90-3AA0■■■	2300/4000	39,048	39,048	39,048	39,048	39,048	39,048	93.6%	2325	
150	3600	449T	1■■3462-2A■90-3AA0■■■	2300/4000	39,048	39,048	39,048	39,048	39,048	39,048	93.6%	2325	
150	1800	449T	1■■3473-4A■90-3AA0■■■	2300/4000	39,728	39,728	39,728	39,728	39,728	39,728	94.5%	2425	
150	1800	449TS	1■■3473-4A■90-3AA0■■■	2300/4000	39,728	39,728	39,728	39,728	39,728	39,728	94.5%	2425	
150	1200	449T	1■■3475-6A■90-3AA0■■■	2300/4000	47,227	47,227	47,227	47,227	47,227	47,227	94.2%	2425	
150	1200	449TS	1■■3475-6A■90-3AA0■■■	2300/4000	47,227	47,227	47,227	47,227	47,227	47,227	94.2%	2425	
200	3600	449TS	1■■3463-2A■90-3AA0■■■	2300/4000	41,590	41,590	41,590	41,590	41,590	41,590	94.2%	2325	
200	3600	449T	1■■3463-2A■90-3AA0■■■	2300/4000	41,590	41,590	41,590	41,590	41,590	41,590	94.2%	2325	
200	1800	449T	1■■3474-4A■90-3AA0■■■	2300/4000	41,306	41,306	41,306	41,306	41,306	41,306	94.4%	2425	
200	1800	449TS	1■■3474-4A■90-3AA0■■■	2300/4000	41,306	41,306	41,306	41,306	41,306	41,306	94.4%	2425	
200	1200	S449T	1■■3491-6A■90-3AA0■■■	2300/4000	51,144	51,144	51,144	51,144	51,144	51,14	94.5%	2975	
200	1200	S449TS	1■■3491-6A■90-3AA0■■■	2300/4000	51,144	51,144	51,144	51,144	51,144	51,14	94.5%	2975	
250	3600	449TS	1■■3464-2A■90-3AA0■■■	2300/4000	44,255	44,255	44,255	44,255	44,255	44,255	95.0%	2325	
250	3600	449T	1■■3464-2A■90-3AA0■■■	2300/4000	44,255	44,255	44,255	44,255	44,255	44,255	95.0%	2325	
250	1800	449T	1■■3475-4A■90-3AA0■■■	2300/4000	44,590	44,590	44,590	44,590	44,590	44,590	95.0%	2425	
250	1800	449TS	1■■3475-4A■90-3AA0■■■	2300/4000	44,590	44,590	44,590	44,590	44,590	44,590	95.0%	2425	
250	1200	S449T	1■■3494-6A■90-3AA0■■■	2300/4000	56,832	56,832	56,832	56,832	56,832	56,832	95.0%	2975	
250	1200	S449TS	1■■3494-6A■90-3AA0■■■	2300/4000	56,832	56,832	56,832	56,832	56,832	56,832	95.0%	2975	
300	3600	S449TS	1■■3481-2A■90-3AA0■■■	2300/4000	47,561	47,561	47,561	47,561	47,561	47,561	95.2%	2825	
300	3600	S449T	1■■3481-2A■90-3AA0■■■	2300/4000	47,561	47,561	47,561	47,561	47,561	47,561	95.2%	2825	
300	1800	S449T	1■■3493-4A■90-3AA0■■■	2300/4000	47,954	47,954	47,954	47,954	47,954	47,954	95.3%	3000	
300	1800	S449TS	1■■3493-4A■90-3AA0■■■	2300/4000	47,954	47,954	47,954	47,954	47,954	47,954	95.3%	3000	
350	3600	S449TS	1■■3482-2A■90-3AA0■■■	2300/4000	51,476	51,476	51,476	51,476	51,476	51,476	95.2%	2825	
350	3600	S449T	1■■3482-2A■90-3AA0■■■	2300/4000	51,476	51,476	51,476	51,476	51,476	51,476	95.2%	2825	
350	1800	S449T	1■■3494-4A■90-3AA0■■■	2300/4000	49,893	49,893	49,893	49,893	49,893	49,893	95.3%	3000	
350	1800	S449TS	1■■3494-4A■90-3AA0■■■	2300/4000	49,893	49,893	49,893	49,893	49,893	49,893	95.3%	3000	

SIMOTICS Advantage Series Motors

MV449 Performance Data

Horse Power	Pole	Speed Full Load - Rpm -	Kva/ HP CODE	Current									
				Full Load 2300v	3/4 Load 2300v	1/2 Load 2300v	No Load 2300v	Locked Rotor 2300v	Full Load 4000v	3/4 Load 4000v	1/2 Load 4000v	No Load 4000v	Locked Rotor 4000v
150	2	3580	G	34.5	27.0	20.1	11.3	218	19.9	15.6	11.6	6.5	125.8
200	2	3580	F	45.6	35.3	26.2	14.4	287	26.3	20.4	15.1	8.3	165.7
250	2	3580	F	55.6	42.8	30.8	15.4	336	32.1	24.7	17.8	8.9	193.9
300	2	3580	E	65.5	49.7	35.2	15.1	381	37.8	28.7	20.3	8.7	220.0
350	2	3580	F	77.4	59.4	42.8	21.1	470	44.7	34.3	24.7	12.2	271.3
150	4	1790	J	36.9	29.8	23.6	16.3	262	21.3	17.2	13.6	9.4	151.4
200	4	1790	H	48.8	39.1	30.7	20.8	339	28.2	22.6	17.7	12.0	196.0
250	4	1790	H	61.0	49.0	38.6	26.3	425	35.2	28.3	22.3	15.2	245.0
300	4	1790	H	71.5	55.9	41.9	24.4	486	41.3	32.3	24.2	14.1	280.8
350	4	1790	H	82.4	64.8	48.8	29.8	564	47.6	37.4	28.2	17.2	326.1
150	6	1190	G	36.5	29.1	22.7	15.6	230	21.1	16.8	13.1	9.0	132.9
200	6	1190	H	48.0	37.9	29.3	19.9	317	27.7	21.9	16.9	11.5	182.8
250	6	1190	H	60.6	48.5	38.1	26.8	418	35.0	28.0	22.0	15.5	241.5

Horse Power	Pole	Speed Full Load - Rpm -	Nominal Efficiency			Power Factor			Torque			Locked Rotor Stall Time	
			1/2 Load (%)	3/4 Load (%)	Full Load (%)	1/2 Load	3/4 Load	Full Load	Full Load (Ft./ Lbs.)	Rotor (Ft./ Lbs.)	Break Down (Ft./ Lbs.)	Stall Time Hot (Sec.)	Stall Time Cold (Sec.)
150	2	3580	91.8	93.2	93.6	75.9	83.5	86.5	220	249	612	54	61
200	2	3580	92.7	93.9	94.2	77.0	84.2	87.0	293	325	800	45	51
250	2	3580	94.2	95.0	95.0	80.2	86.2	88.3	367	407	940	41	57
300	2	3580	94.7	95.3	95.2	84.2	88.6	89.8	440	475	1065	42	48
350	2	3580	94.4	95.2	95.2	80.7	86.5	88.5	513	585	1313	33	39
150	4	3585	92.9	94.2	94.5	63.9	74.8	80.1	440	506	1254	51	61
200	4	1790	93.0	94.1	94.4	65.4	75.9	80.8	587	763	1591	39	51
250	4	1790	93.7	94.7	95.0	64.5	75.2	80.5	734	1028	1974	40	45
300	4	1790	94.7	95.3	95.3	70.4	78.8	82.1	881	1057	2123	43	49
350	4	1790	94.5	95.2	95.3	70.7	79.4	83.0	1028	1316	2498	37	42
150	6	1190	92.8	94.0	94.2	66.6	76.8	81.4	663	849	1677	43	49
200	6	1190	93.6	94.5	94.5	67.9	77.9	82.3	884	1202	2281	37	43
250	6	1190	94.0	94.9	95.0	65.1	75.9	80.9	1105	1635	3050	30	36



SIMOTICS Advantage Series Motors

MV449 Introduction

General Information

Wide selection

Providing value also means having the right motor for the job. At Siemens, we strive to offer a wide variety of motor types in many different frame sizes, with many different power ratings. This section only covers our medium voltage 449 and S449 frame sizes. Visit our AboveNEMA website at www.usa.siemens.com/motors and click on the "Large AC Above NEMA motors" link or scan our QR code at the end of the catalog to access our website via mobile device to browse all of our other options. The Norwood, OH plant offers both horizontal and vertical AC squirrel-cage induction motors with power ratings up to 20,000 horsepower. Larger induction motors are also available from other Siemens plants.

The right efficiency for your application

To meet your cost of ownership and motor management needs, Siemens offers different levels of energy efficiency in its medium voltage 449 motors:

- NEMA Standard on all Power Ratings (MG1 Table 12-11)
- NEMA Premium® Efficiency on 250HP and above Power Ratings (MG1 Form Wound Table 12-13)

Total customer support

When you're looking for a motor, look for a highly trained specialist to help you match the right motor to your specific needs. Siemens sales engineers have the knowledge, training, and experience to help you solve performance or installation challenges, ensuring the best value for your investment. Our experts can also perform fully functional retrofits of previous long-standing motors to maximize your plant operation time.

Customer Service for Optimum Performance

Our global network of repair centers is constantly growing, as well as our number of local Field Service experts, to ensure your motor maximum up-time. We also offer product support over the

motors complete service life to ensure our customers are continuously satisfied. Our customer service centers take pride in putting our customers first. Whether it's an expedited shipment, tracking of your order, or making sure your motor is properly installed, these professionals won't be satisfied until you are. In addition, we offer 24/7 On-Call service to ensure a quick response time.



Siemens Manufacturing & Stocking Facility

4620 Forest Avenue
Norwood, OH 45212

Availability

Siemens has begun stocking our medium voltage 449 and S449 frames, so contact your local Siemens representative to get your quote.

Quality from Experience

The quality of our motors begins with the design experience we have gained through more than 120 years of manufacturing and installing motors. We build on this experience every day with new designs that incorporate the latest materials and techniques to provide even higher levels of performance, operating efficiency, and reliability. These advanced motor designs are assembled in our state-of-the-art, ISO 9001 Certified Norwood, OH facility. This 350,000 square foot facility has produced over 150,000 high and medium voltage motors with the highest quality machinery available.



SIMOTICS Advantage Series Motors

MV449 Standard Features

MV449 TEFC motors meet/exceed NEMA Premium® efficiency above 250HP. With our exclusive, leading-edge, die cast aluminum (frames 449-S449) rotor designs, these motors significantly reduce operating costs and pay for themselves in a short time through energy savings. These industry workhorses are ideal for uses in the Power Generation, Pulp & Paper, Water & Wastewater, Chemical industries, etc. Specific applications may include, but are not limited to: Pumps, Compressors, Blowers, Mixers, Conveyor Systems, Extruders and Cooling Towers.



HP Range	150-350 HP	449 – S449
Efficiency	NEMA Standard	449 – S449
	NEMA Premium®	449 – S449 ¹⁾
Voltage	2300/4000 V	3 Phase 60Hz
Insulation	Insulation Class F	NEMA Design B
	Temperature Rise (Sine Wave)	Class B @1.0SF Class F @1.15SF
Frame	-	Cast Iron
	Eight Hole Feet	Casted
	Condensation Drains	Two on Lowest Point in Frame
	High Strength Carbon Steel Shaft	C1045-449TS, C4140: S449-449T
	V Ring Slinger – IP54	DE & NDE
	Bearing Isolator ²⁾	449 – S449
Stator/Rotor	Stator	Form Wound Copper
	Rotor	Die Cast Aluminum
Conduit Box	Fabricated	449 – S449
Bearings	Double Shielded	449 – S449
	Single Shielded	449 – S449
	Bearing Housing	Cast iron – Bearing Caps
	Grease	Polyrex EM NLGI 2
	Inlet/Relief Fittings	Alemite/Plug
Fan	Cover	Cast Iron – 449 – S449
	Unidirectional/Bidirectional	Aluminum – 449 – S449
Hardware	Nameplate ³⁾	--
	Lifting Eyebolt	--
	Paint	Two Part Epoxy
Inverter Duty	Variable Torque 10:1	449 – S449
	Constant Torque 2:1	--
Hazardous Classification	Service Factor 1.15 ⁴⁾	449 – S449 Class I, Division 2, Gr. B, C, or D T3 Temperature Code

NEMA Premium® is a certification mark of the National Electrical Manufacturers Association.

1. NEMA Premium® efficiency is only met at 250HP and above.
2. Inproseal® (K91: DE, K92: NDE)
3. Nameplate options (Y80: Derate, Y82: Auxiliary, K44: Replica of main, D44: Division 2)
4. Service Factor of 1.0 for both 350HP ratings



SIMOTICS Advantage Series Motors

MV449 Modifications & Accessories

Siemens offers a wide selection of options to increase the suitability of our motors to the customer's specific needs. A specific device manufacturer should not be specified unless it is absolutely the only one that is acceptable for that application. The complete specification of the needed device without supplier identification is the preferred specification arrangement. The insistence on a specific supplier of a device can result in time delays since the item must be special ordered.

Ordering Instructions:

1. Select a MV449 stock motor from the **SIMOTICS Advantage Series Standard Features Section**. (Note MLFB Article Number)
2. Select applicable Option(s). (Note Order Code, Order Code Position and List Price Adder)
3. Construct new Part Number and List Price. (See example below)
 - a) If the Order Code Position is 12, replace the figure(s) or letter(s) at the same position in the stock motor **Part Number** with the **Custom Option Order Code**.
 - b) If the Option Order Code Position is Z, add a '-Z' to the end of the stock motor **Part Number**. Then add a space followed by the **Custom Option Order Code** in alphanumerical order. Each order code will be followed by a '+' until the final one.

Custom Options Pricing Example: 250HP, 3600RPM, 2300/4000V, 449TS, Die Cast Aluminum Rotor, with feet, without flange, PTC thermistors-1/phase (3 embedded temperature sensors for tripping), Anti-Fungal Treatment with tropicalization moisture and F-2 Assembly.

Base List Price: \$44,255 Part Number: 1LA34642AA903AA0L1C

List Price Adders:

(3)PTC Thermistors-1/phase	\$1,707	Order Code A15 , Order Code Position Z
Anti-Fungal Treatment	\$1,541	Order Code S00 , Order Code Position Z
F-2 Assembly	\$1,124	Order Code K09 , Order Code Position Z

Total List Price: \$48,627 **NEW Part Number:** 1LA34642AA903AA0L1C-Z A15+K09+S00

Delivery: Please contact Siemens for delivery



SIMOTICS Advantage Series Motors

MV449 Modifications & Accessories (continued)

Altitude

TEFC motors are designed to operate within Class B temperature rise limits when operated at rated horsepower at altitudes up to 3300 feet. For altitudes from 3301-5000 feet, utilization to Class F temperature rise limits are enacted. Please consult Siemens for altitudes above 5000 feet. Standard motors will operate at their rated service factor at altitudes above 3300 feet at the corresponding ambient temperatures as shown in the table below.

Ambient

TEFC motors are designed to operate within certain maximum temperature rise limits when the motor is operated in ambient temperatures from -25°C to 40°C. For Class B rated motors, the limit is 80°C rise by resistance at a 1.0 service factor.

Maximum Altitude	Ambient Temperature
3300 ft. (1000m)	40°C (104°F)
6600 ft. (2000m)	30°C (86°F)
9900 ft. (3000m)	20°C (68°F)

Assembly- Mounting Positions

As standard, these motors are supplied for horizontal, foot mounting and NEMA F-1 assembly.

Mounting Positions

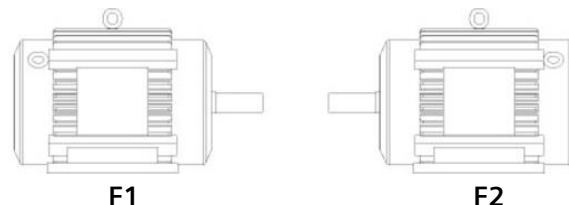

Code	Option Description	Lead Time	List Adder
K09	F-2 Assembly	2 days	\$1,124

Bearings – Insulation

As standard, all motors have the non-drive end bearing insulated.

Code	Option Description	Lead Time	List Adder
L18	Both Bearings Insulated	2 days	\$1,395

SIMOTICS Advantage Series Motors

MV449 Modifications & Accessories (continued)

Bearings – Roller Bearings

Motors having roller bearings require a minimum radial load. Use of these motors in direct connected applications is discouraged to avoid excessive drive end bearing noise and/or reduced bearing life.

Code	Option Description	Lead Time	List Adder
K20	Roller Bearings	10 days	\$2,617

Bearing Protective Devices- Temperature

- A. Temperature Detectors (RTD's) - Bearing RTD's are available per the following chart. Stick-type are available for anti-friction bearings. The standard bearing RTD is a tip sensitive device consisting of a probe with a hermetically sealed tip inside of which is a resistance element in the form of a coil. The remainder of the assembly consists of a protective stainless-steel sheath to which the probe is attached. The RTD leads are brought internally to a terminal block in an auxiliary terminal box. No additional insulation within sheathing is offered besides the insulation on the lead wire itself.

Code	Option Description	Lead Time	List Adder
R79	(2) 100 Ohm Platinum (0.00385 TCR) DIN Std, single-element RTDs, 3-wire, 1/brg, stick-type	3 days	\$2,247

Cancellation Charges

A minimum charge of 10% of the total order value will be assessed for any order cancellation. For any order less than \$5,000 (e.g. parts order), a minimum charge of \$500 will be assessed for any order cancellation. A charge of 15% of the total motor price will be assessed if an order is canceled after it has been released for engineering and drafting, whether or not the drawings have been completed and/or submitted for approval.

Note: The following graph will apply to determine cancellation charges after the order is received and entered at the factory

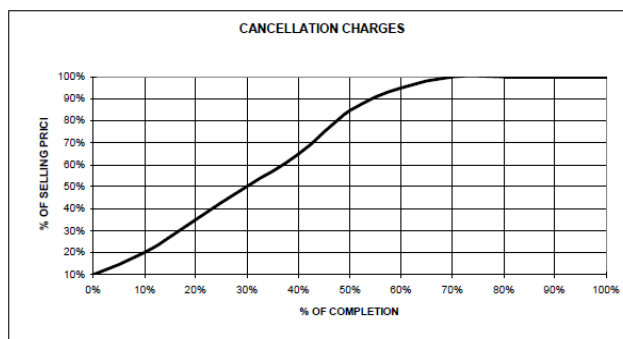

SIMOTICS Advantage Series Motors

MV449 Modifications & Accessories (continued)

Couplings

Includes mounting only of shrink-fit, customer-supplied coupling which has been finish-bored and key-seated to Siemens standard shaft dimensions for this product. Couplings are to be sent freight prepaid to arrive at the factory at by date specified by Siemens.

Code	Option Description	Lead Time	List Adder
L17	Mount Customer Supplied ½ Coupling	3 days	\$2,299

Direction of Rotation

Ratings indicated as "Uni-directional" (2P S449) will be listed CW as standard. All other ratings are Bi-directional. For a specific direction of rotation to be included, please choose from below.

Code	Option Description	Lead Time	List Adder
K97	Clockwise Viewed from Drive End	2 days	\$239
K98	Counter-Clockwise Viewed from Drive End	2 days	\$239
K99	Bi-Directional Rotation (when applicable)	2 days	\$239

Export Packaging- Sea Freight Packaging

For motors to be export packaged per Siemens standard overseas shipment. Please add 5 working days to the standard lead-time for export boxing. See Shipment Terms & Packaging for additional information.

Code	Option Description	Lead Time	List Adder
S98	Sea Freight Packaging	5 days	\$4,007

Hazardous Location and Temperature Code

Class I: Where potentially explosive flammable gases or vapors are in the air

Division II: Location where hazardous material exists only in the case of fault situations (leaky valve, burst pipe, faulty equipment, etc.)

Gr. B Hydrogen

Gr. C Atmospheres containing ethyl and ether vapor

Gr. D Atmospheres containing gasoline, petroleum, naphtha, alcohols, acetone lacquer solvent vapors and natural gas.

T3: Maximum surface temperature not to exceed 200°C (392°F)

IEEE 841 Standard - 2009

This standard applies to premium-efficiency TEFC's up to 500 horsepower and 4000 volts. It is used in petroleum, chemical, and other severe-duty applications. The purpose of this standard is to define specifications for mechanical and electrical performance, corrosion protection, electrical insulation systems, and testing. For 2 pole motors, exception is taken to twice speed or twice frequency vibration.

Code	Option Description	Lead Time	List Adder
R61	IEEE 841 Standards	5 days	\$6,589

SIMOTICS Advantage Series Motors

MV449 Modifications & Accessories (continued)

Nameplates

There are multiple different options available when it comes to including specific information on your nameplates, which are listed in the table below.

Code	Option Description	Lead Time	List Adder
K44	Additional Replica of Main Motor Nameplate	2 days	\$239
Y80	Derate Nameplate (SF, Altitude, or Ambient Temperature)	2 days	\$1,415
Y82	Auxiliary Nameplate (Max. 40 Characters)	2 days	\$239
D44	Division 2 Nameplate	2 days	\$708

Paint

Siemens standard finish paint consists of the following:

Primer: Interior and exterior coated with epoxy or epoxy ester primer (subcomponent-specific, determined by vendor). Dry film thickness*: 1-4 mils (25-100 µm)

Finish Coat: One coat of two-part polyamide epoxy applied to all visible surfaces of the motor except shaft extensions, oil sight glass, machined surfaces, etc. Dry film thickness*: 4-8 mils (100-200 µm)

Paint is allowed to dry for at least four hours before handling (or dried for one hour, then baked for 30-60 minutes at 200° F). Bakes if air temperature is below 55° F.

Total system dry film thickness*: 5-12 mils (130-305 µm)

Standard Color: Munsell 8.3B 3.54/1.9 (Motor Blue)

*Measurement and acceptance criteria are per SSPC-PA 2. Film thickness levels have been developed in accordance with the recommendations of the paint manufacturer.

Shaft Seal

For additional shaft seal options, please choose from the list below.

Code	Option Description	Lead Time	List Adder
K51	IP56 Shaft Seal	3 days	\$2,506
K91	INPRO/SEAL® - Drive End	2 days	\$2,465
K92	INPRO/SEAL® - Opposite Drive End	2 days	\$2,465

Shipment Terms & Packaging

Standard shipment terms are FCA Loaded, Norwood, OH factory, freight collect with our standard domestic packaging only. Contact your local Siemens Sales representative for other Incoterms.

Stator- Treatment

All motors, 2300 volt and above, have form wound stator coils with a Siemens' standard VPI insulation system. An Anti-Fungal Treatment is offered for the stator in humid areas, which utilizes a tropicalization moisture for protection.

Code	Option Description	Lead Time	List Adder
S00	Anti-Fungal Treatment, Tropicalization Moisture	3 days	\$1,541



SIMOTICS Advantage Series Motors

MV449 Modifications & Accessories (continued)

Stator- Protective Devices

- A. Thermistors - The thermistors used are positive temperature coefficient (PTC) sensors. They are embedded in the end turns of the windings in the stator. A set of sensors consists of three sensors, one per phase. The resistance of the sensor remains relatively low and constant over a wide temperature band and increases abruptly at a predetermined temperature. When this occurs, the sensor acts as a solid-state thermal switch and, when connected to a matched solid-state electronic switch in an enclosed control module, it de-energizes a pilot relay. The relay, in turn, opens the motors control circuit or the control coil of an external line break contactor to shut down the protected equipment.

Code	Option Description	Lead Time	List Adder
A15	Thermistors – (3) PTC - 1/Phase	3 days	\$1,707
A16	Thermistors – (6) PTC - 2/Phase	3 days	\$1,966
A25	KTY84 Thermistors (2)	3 days	\$1,855

- B. Thermostats - Thermostats use a snap-action, bi-metallic, disc type switch to open or close a circuit upon reaching a preselected temperature. When heated, the stresses in the disc cause it to reverse its curvature instantaneously when the bi-metal reaches a predetermined temperature. The action of the disc opens or closes a set of contacts in an energized control circuit. Thermostats are available with contacts for normally open or normally closed operation, but the same device cannot be used for both. Note: These devices are pre-calibrated by the manufacturer and are not adjustable.

Code	Option Description	Lead Time	List Adder
R16	Thermostat - (2) TI Klixon; normally closed contacts	3 days	\$2,056

Testing

Routine Test (499 Test) - This test series defines the tests and data collection to meet the NEMA MG 1 and IEEE 112 requirements for a Routine Test.

Calculations and data forms used to determine results of testing from raw data are per IEEE 112 and are retained, not reported.

Certified Final Test Report forms submitted to the customer are per IEEE 112, Annex B.

Description	Report
Idle run – Measure & record current, volts, power, speed	DR/R
AC High potential test @ 2X rated volts + 1000 volts	DR/R
Insulation resistance	DR/R
Stator winding resistance	DR/R
Vibration - horizontal, vertical, axial	DR/N
Bearing insulation	DR/N
Air gap measurement	DR/N
Space heater resistance	DR/N
[If bearing RTD's ordered] Stator and bearing RTD resistance	DR/N
[If stator RTD's ordered] RTD high potential test	DR/N
[If thermostats ordered] Thermostat high potential test	DR/N
[If aluminum rotor] Rotor test	DR/N
LEGEND: DR/R = Documentation Retained/Reported DR/N = Documentation Retained/Not reported	

Warranty Offerings

For a copy of our Standard Warranty (36 months) refer detailed requirements to your local Siemens Sales representative.

SIMOTICS Advantage Series Motors

MV449 General Dimensions

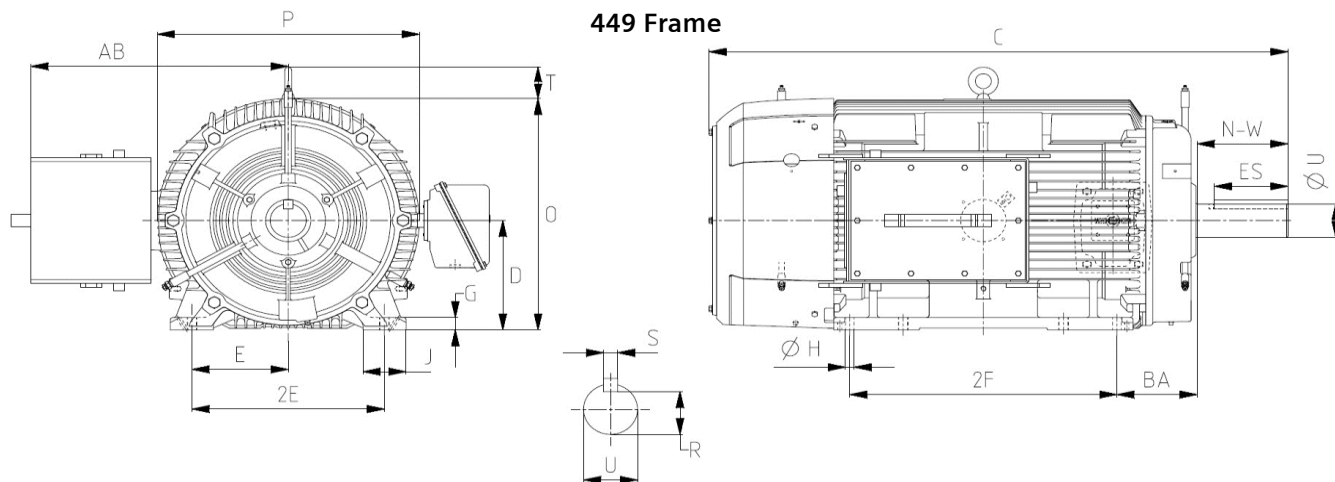

Frame	Poles	C	2F		N-W	P	BA	AB	2E	D	O	Keyseat		
			447	449								R	S	ES
449T	All	53.8	20	25	8.5	25.3	7.5	24.1	18	11	23.2	2.88	0.875	6.88
449TS	All	50.1	20	25	4.75	25.3	7.5	24.1	18	11	23.2	2.021	0.625	3

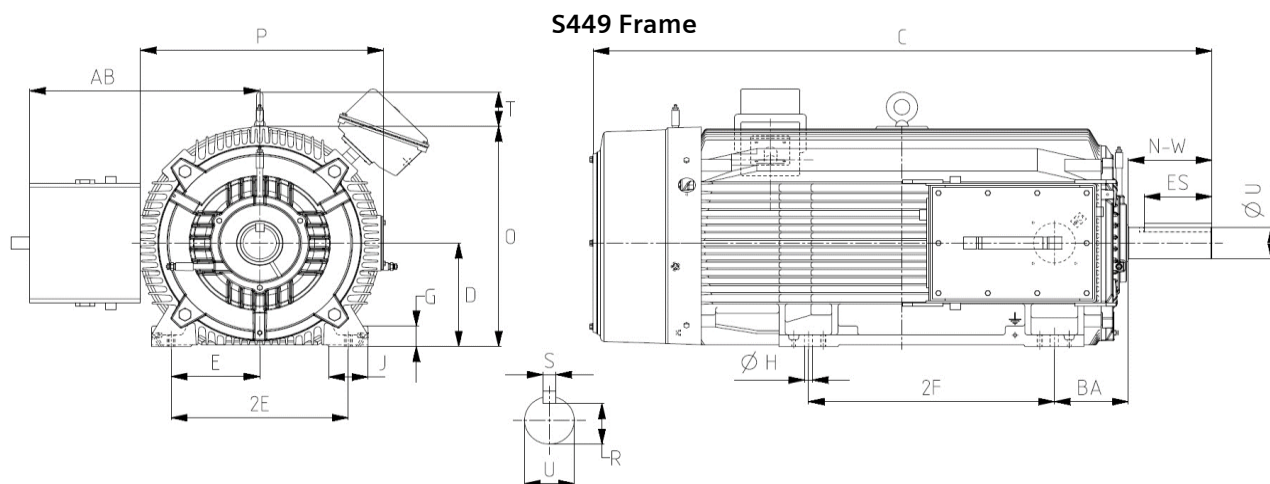

Frame	Poles	C	2F	N-W	P	BA	AB	2E	D	O	Keyseat		
											R	S	ES
S449T	4 - 6	62.9	25	8.5	24.9	7.5	23.4	18	11	23.4	2.88	0.875	6.88
S449TS	2	62.6	25	4.75	24.9	7.5	23.4	18	11	23.4	2.021	0.625	3
S449TS	4 - 6	59.2	25	4.75	24.9	7.5	23.4	18	11	23.4	2.021	0.625	3



SIMOTICS Advantage Series Motors

MV449 General Dimensions

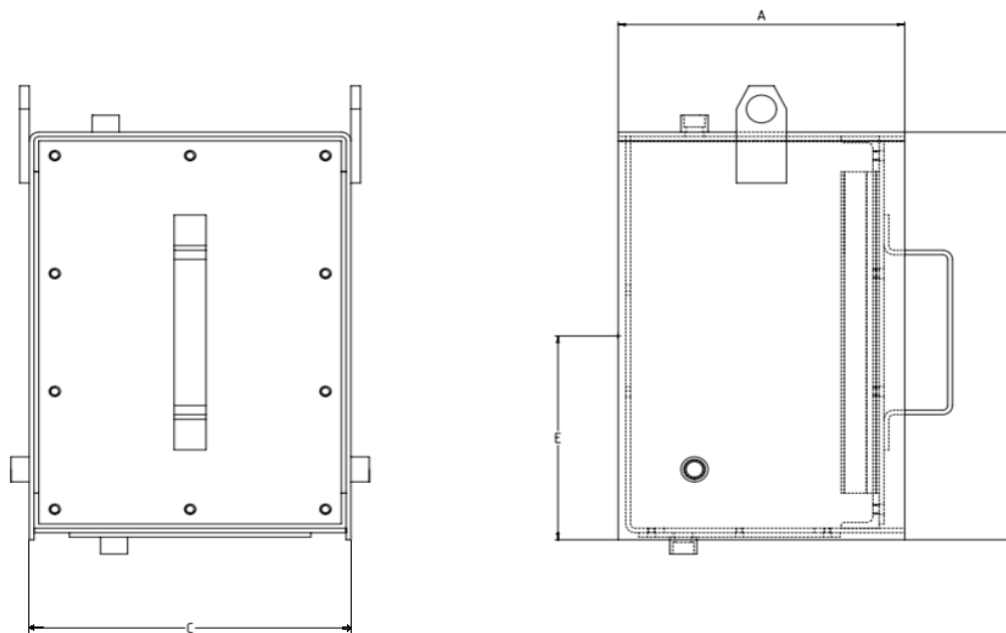

Frame	External Dimensions (in)				Approx. Internal volume (in ³)	Number of Cover Bolts
	A	C	D	E		
449T	11.3	12.6	17.4	8.2	2477.4	10
449TS	11.3	12.6	17.4	8.2	2477.4	10
S449T	11.3	12.6	17.4	8.2	2477.4	10
S449TS	11.3	12.6	17.4	8.2	2477.4	10



Codes Index

Codes	Description	For further information, see page(s)	For price information, see page(s)
A40	Space Heaters 115V Single Phase	2-14 , 2-15	4-2 , 4-9
A41	Space Heaters 230V Single Phase	2-14 , 2-15	4-2 , 4-9
A42	Space Heaters 115V Single Phase, Division 2	2-14 , 2-15	4-2 , 4-9
A43	Space Heaters 115V Single Phase, Explosion Proof	2-14 , 2-15	4-2 , 4-9
A44	Space Heaters 230V Single Phase, Division 2	2-14 , 2-15	4-2 , 4-9
A45	Space Heaters 230V Single Phase, Explosion Proof	2-14 , 2-15	4-2 , 4-9
A46	Space Heaters 115V Single Phase, Max Temp 160°C	2-14 , 2-15	4-2 , 4-9
A47	Space Heaters 230V Single Phase, Max Temp 160°C	2-14 , 2-15	4-2 , 4-9
A50	Install BRG RTD's-100 Ohm Platinum- Both Ends & Terminal Heads/Block	2-21 , 2-24	4-4 , 4-12
A51	Bearing RTD's-100 Ohm Platinum – Both Ends & Terminal Heads/Block	2-20 , 2-21 , 2-24	4-12
A66	ROBERTSHAW Vibration Detectors, Model 366-D8 120VAC	2-36 , 2-37	4-15
A67	Provision Only for Vibration Sensors (PMC/Beta)	2-36 , 2-37	4-15
A90	Control Module	2-14	4-9
B09	Export Packaging Sea Freight - Siemens Standard	2-40	4-6 , 4-15
B10	Export Packaging Special Export Box	2-40	4-15
B27	+40C to -30C Ambient Temp	2-21 , 2-31 , 2-35	4-14
B28	+40C to -40C Ambient Temp	2-21 , 2-31 , 2-35	4-14
B29	+40C to -50C Ambient Temp	2-21 , 2-31 , 2-35	4-14
C00	Insulation Class H	2-14 , 2-39 , 2-45	4-9
C01	Insulation Vacuum Pressure Impregnation (VPI)	2-14	4-9
C03	Spike Resistant Wire	2-14 , 2-39 , 2-45	4-9
C04	Insulation Moisture/Powerhouse (Extra Dip & Bake)	2-14	4-9
C07	Insulation Fungus Protection - No UL	2-14	4-2 , 4-9
C08	Insulation Tropicalization (Extra Dip & Bake + Fungus Spray)	2-14	4-9
D05	Documentation in Spanish	2-42 , 2-43	4-16
F00	Certificate of Compliance	2-42 , 2-43	4-6 , 4-16
F03	Standard Performance Curves	2-42 , 2-43	4-6 , 4-16
F07	Special Calculated Data	2-42 , 2-43	4-6 , 4-16
F10	Routine Test Report	2-44	4-6 , 4-16
F12	Routine Test Report (Witnessed)	2-44	4-6 , 4-16
F15	Complete Test	2-44	4-6 , 4-16
F17	Complete Test (Witnessed)	2-44	4-6 , 4-16
F20	Routine Test + Vibration	2-44	4-6 , 4-16
F22	Routine Test + Vibration (Witnessed)	2-44	4-6 , 4-16
F27	Performance Load Test (Curve Report)	2-44	4-6 , 4-16
F30	Noise Test	2-44	4-6 , 4-16
F32	Noise Test (Witnessed)	2-44	4-6 , 4-16
F36	Routine Test Report of Electrical Duplicate Design	2-44	4-6 , 4-16
F37	Type Test Report of Electrical Duplicate Design	2-44	4-6 , 4-16
F40	Stall Time Curve (Thermal Limit Curve)	2-42 , 2-43	4-6 , 4-16
F42	Standard Dimensional Sheet	2-42 , 2-43	4-6 , 4-16
F43	Non-Standard Dimension Sheet	2-42 , 2-43	4-6 , 4-16
F44	Conduit Box Dimension Sheet	2-42 , 2-43	4-6 , 4-16
F45	Wiring Diagram	2-42 , 2-43	4-6 , 4-16
F46	Instruction and Operation Manual in English	2-42 , 2-43	4-6 , 4-16
F47	Renewal Parts	2-42 , 2-43	4-6 , 4-16
F49	Performance Data Sheets	2-42 , 2-43	4-6 , 4-16
F50	Customer Specific Data Sheets	2-42 , 2-43	4-6 , 4-16
F90	IEC EX Certification	2-44	4-16
G05	DYNAPAR Encoder HS35 1024 PPR	2-36 , 2-37	4-15
G06	C-Face Mounted SLIM Tach Encoder	2-36 , 2-37	4-15
H04	C-Face Mounted Brake	2-36 , 2-38	4-15
J00	Separate Condulet on Main Box Side for PTC Thermistors	2-17 , 2-20	4-10
J02	Condulet to Main Box for PTC Thermistors	2-17 , 2-20	4-10
J03	Aux Box to Main Box for PTC Thermistors	2-17 , 2-20	4-10
J04	Condulet Opposite to Main Box Side for PTC Thermistors	2-17 , 2-20	4-10



Codes Index (continued)

Codes	Description	For further information, see page(s)	For price information, see page(s)
J05	Aux Box Opposite to Main Box Side for PTC Thermistors	2-17, 2-20	4-10
J06	Explosion Proof Condulet Opposite to Main Box Side for PTC Thermistors	2-17, 2-20	4-10
J07	Aux Box to Left of Main Box for PTC Thermistors	2-17, 2-20	4-10
J10	Separate Condulet on Main Box Side for Thermostats	2-17, 2-20	4-3, 4-10
J11	Aux Box on Same Side as Main for Thermostats	2-17, 2-20	4-3, 4-10
J12	Condulet to Main Box for Thermostats	2-17, 2-20	4-3, 4-11
J13	Aux Box to Main Box for Thermostats	2-17, 2-20	4-3, 4-11
J14	Condulet Opp Side to Main for Thermostats	2-17, 2-20	4-3, 4-11
J15	Aux Box Opp Side to Main for Thermostats	2-17, 2-20	4-3, 4-11
J16	Explosion Proof Condulet Opp to Main for Thermostats	2-17, 2-20	4-11
J17	Explosion Proof Condulet to Main Box for Thermostats	2-17, 2-20	4-11
J20	Condulet on Same Side of Main Box for PT1000 Temperature Sensors	2-17, 2-20	4-11
J21	Aux Box on Same Side as Main for PT1000 Temperature Sensors	2-17, 2-20	4-11
J22	Condulet to Main Box for PT1000 Temperature Sensors	2-17, 2-20	4-11
J23	Aux Box to Main Box for PT1000 Temperature Sensors	2-17, 2-20	4-11
J24	Condulet Opposite to Main Box Side for PT1000 Temperature Sensors	2-17, 2-20	4-11
J25	Aux Box Opposite Main Box Side for PT1000 Temperature Sensors	2-17, 2-20	4-11
J26	Explosion Proof Condulet Opposite to Main Box Side for PT1000 Temperature Sensors	2-17, 2-20	4-11
J27	Explosion Proof Condulet to Main Box for PT1000 Temperature Sensors	2-17, 2-20	4-11
J50	Separate Condulet on Main Box Side for Space Heaters	2-17, 2-20	4-3, 4-11
J51	Aux Box on Same Side as Main for Space Heaters	2-17, 2-20	4-3, 4-11
J52	Condulet to Main Box for Space Heaters	2-17, 2-20	4-3, 4-11
J53	Aux Box to Main Box for Space Heaters	2-17, 2-20	4-3, 4-11
J54	Condulet Opposite to Main Box Side for Space Heaters	2-17, 2-20	4-3, 4-11
J55	Aux Box Opposite Main Box Side for Space Heaters	2-17, 2-20	4-3, 4-11
J56	Explosion Proof Condulet Opposite to Main Box Side for Space Heaters	2-17, 2-20	4-11
J57	Explosion Proof Condulet to Main Box for Space Heaters	2-17, 2-20	4-12
J84	Conduit Box Orientation 90° CCW (Entry from DE)	2-17, 2-18	4-3, 4-12
J85	Conduit Box Orientation 180° CCW (Entry from Top)	2-17, 2-18	4-3, 4-12
J86	Conduit Box Orientation 270° CCW (Entry from ODE)	2-17, 2-18	4-3, 4-12
K10	IEEE 841 Features	2-27, 2-36	4-15
K20	API 610	2-23, 2-36	4-15
K21	Extra High Thrust	2-21, 2-23, 2-36	4-12
K33	Drip Cover	2-29, 2-30	4-5, 4-14
K34	Lifting Hooks (No Drip Cover)	2-29	4-5, 4-14
K38	Provisions for Dowel Holes	2-29	4-5, 4-14
K41	Keyless Shaft	2-26, 2-27	4-13
K70	Rotation Arrow Bidirectional (Not for Uni-Directional)	2-29, 2-30	4-5, 4-14
K71	Rotation Arrow Clockwise (From NDE)	2-29, 2-30	4-5, 4-14
K72	Rotation Arrow Counterclockwise (From NDE)	2-29, 2-30	4-5, 4-14
K80	BURNDY HYDENT YA Type Terminals	2-17	4-3, 4-12
K81	Special Cable Leads, 60" Long	2-17, 2-20	4-12
K82	Special Cable Leads, 120" Long	2-17, 2-20	4-12
K83	Terminal Block - 3 Lead Only	2-17, 2-20	4-3, 4-12
K89	Sealed Leads	2-17	4-3, 4-12
L01	Cast Iron Main Terminal Box in Lieu of Aluminum	2-17, 2-18	4-3, 4-12
L20	Lifting Eyebolt	2-29	4-5, 4-14
L22	Stainless Steel Hardware (Includes T Drain SS)	2-29, 2-31	4-5, 4-14
L27	Ground Bolts - Qty 2	2-29, 2-31	4-5, 4-14
L29	Shaft Grounding Brush	2-26, 2-28	4-4, 4-13
L45	SS T-Slot Breather Drain	2-29, 2-31	4-5, 4-14
L46	CROUSE HINDS UL Approved Breather Drain	2-29, 2-31	4-5, 4-14
L54	Provisions for Oil Mist	2-21	4-12
L55	Oil Mist Ready	2-21	4-12
L57	MOBIL 28 - High or Low - Special Grease	2-21	4-4, 4-12
L58	MOBILITH SHC 100 - Special Grease	2-21	4-4, 4-12



Codes Index (continued)

Codes	Description	For further information, see page(s)	For price information, see page(s)
L60	ALEMITE and Grease Relief Fitting	2-21	4-4, 4-12
L61	Insulated Bearing - INSOCOAT (Both Ends)	2-21, 2-25	4-4, 4-12
L64	Insulated Bearing - INSOCOAT (NDE only)	2-21, 2-25	4-4, 4-12
L65	Roller Instead of Ball Bearings	2-21, 2-22, 2-24	4-12
L66	Insulated Bearings on Both Ends	2-21, 2-25	4-13
L67	Insulated NDE Only	2-21, 2-25	4-13
L68	Sealed Ball Bearings (Both Ends)	2-21	4-4, 4-13
L69	Hybrid (Ceramic Ball) Bearings - Both Ends	2-21, 2-25	4-4, 4-13
L70	Hybrid (Ceramic Ball) Bearings – NDE	2-21, 2-25	4-4, 4-13
L71	Hybrid (Ceramic Ball) Bearings – DE	2-21, 2-25	4-4, 4-13
L76	Shaft Slinger & O Ring	2-26, 2-27	4-4, 4-13
L79	INPRO/SEAL DE	2-26, 2-27	4-4, 4-13
L80	INPRO/SEAL ODE	2-26, 2-27	4-4, 4-13
L81	INPRO/SEAL Both Ends	2-26, 2-27	4-4, 4-13
L84	Brass Seal	2-26	4-4, 4-13
L86	INPRO/SEAL MGS Shaft Grounding - Both Ends	2-26, 2-28	4-4, 4-13
L87	ORION Labrinth Copper Seal – DE	2-26, 2-27	4-4, 4-13
L88	ORION Labrinth Copper Seal – ODE	2-26, 2-27	4-4, 4-13
L89	ORION Labrinth Copper Seal – Both Ends	2-26, 2-27	4-4, 4-13
L90	IP66 Ingress Protection	2-29, 2-31	4-5, 4-14
M05	Larger Fan	2-36, 2-39, 2-45, 2-46	4-5, 4-15
M08	Separately Driven Fan	2-36, 2-39, 2-45	4-15
M09	Aluminum Fan	2-29, 2-30	4-5, 4-14
M10	Bronze Fan	2-29, 2-30	4-5, 4-14
M18	Non-Reverse Ratchet	2-36, 2-39	4-15
M1Y	Special Voltage 200-460V	2-10	4-7
M21	Additional Nameplate (Without Logos)	2-32, 2-33	4-14
M22	Class I, Division 2 Tag	2-32, 2-33	4-5, 4-14
M23	Space Heaters Caution Plate	2-32, 2-34	4-5, 4-14
M24	Lubrication Plate	2-32, 2-34	4-5, 4-14
M25	Class II, Division 2	2-32, 2-33, 2-45	4-5, 4-14
M28	Stainless Steel Eyebolt	2-29, 2-31	4-5, 4-14
M2Y	Special Voltage 461 - 600VR	2-10	4-7
M32	Class II, Group E Hazardous Area	2-32, 2-33	4-14
M39	Vertical Jacking Provisions	2-29	4-5, 4-14
M42	Shaft Ring Brush (Steel) – NDE (AEGIS)	2-26, 2-28	4-13
M52	NEMA Std Long Shaft – NDE	2-26, 2-27	4-13
M53	NEMA Std Short Shaft – NDE	2-26, 2-27	4-13
M57	(C4140) Carbon Steel Shaft	2-26	4-13
M69	Precision Balance	2-36	4-5, 4-15
M70	Extra Precision Balance	2-36	4-5, 4-15
N01	2 Part Epoxy (Industrial – Coastal Low Salt)	2-40, 2-41	4-15
N02	3 Part Epoxy (Industrial – Coastal Moderate Salt)	2-40, 2-41	4-15
N03	Primer Only	2-40, 2-41	4-15
N05	3 Part Epoxy (Coastal – Offshore High Salt)	2-40, 2-41	4-15
T00	Main Terminal Box – at 45° Angle	2-17, 2-19	4-3, 4-12
T25	Aux Terminal Box – at Non Drive End Side	2-17	4-3, 4-12
Y50	Special Shaft on Drive End	2-26, 2-27	4-13
Y51	Special Shaft on Non Drive End	2-26, 2-27	4-13
Y60	Special Color (Provide RAL#)	2-40, 2-41	4-15
Y80	Derate-Alt-Amb (Nameplate Change)	2-10, 2-32, 2-34, 2-35	4-5, 4-14
Y82	Auxiliary Nameplate Max. 40 Characters (Aux Tag)	2-32, 2-34	4-5, 4-14
Y85	Special Cable Length	2-17, 2-20	4-12



Siemens

100 Technology Drive
Alpharetta, GA 30005

1-800-365-8766

info.us@siemens.com

Subject to change without prior notice

Order No.: NMCA-00001-0819

All rights reserved

Printed in USA

© 2019 Siemens

The technical data presented in this document is based on an actual case or on as-designed parameters, and therefore should not be relied upon for any specific application and does not constitute a performance guarantee for any projects. Actual results are dependent on variable conditions. Accordingly, Siemens does not make representations, warranties, or assurances as to the accuracy, currency or completeness of the content contained herein. If requested, we will provide specific technical data or specifications with respect to any customer's particular applications. Our company is constantly involved in engineering and development. For that reason, we reserve the right to modify, at any time, the technology and product specifications

